

## Operating manual

### wms ultrasonic sensor

wms-25/RT/HV/M18      wms-340/RT  
 wms-35/RT              wms-600/RT  
 wms-130/RT

### Product Description

The wms sensors require a connection to the customer's own control and signal evaluation equipment.

### Safety Notes

- Read the operating manual prior to start-up.
- Connection, installation and adjustments may only be carried out by qualified staff.

- No safety component in accordance with the EU Machine Directive, use in the area of personal and machine protection not permitted.

The wms sensors indicate a **blind zone**, in which the distance cannot be measured. The **operating range** indicates the distance of the sensor that can be applied with normal reflectors with sufficient function reserve. When using good reflectors, such as a calm water surface, the sensor can also be used up to its **maximum range**. Objects that strongly absorb (e.g. plastic foam) or diffusely reflect sound (e.g.

pebble stones) can also reduce the defined operating range.

### Proper Use

wms ultrasonic sensors are used for non-contact detection of objects.

### Installation

- Mount the sensor at the place of fitting.
- Connect a connection cable to the M12 device plug.
- Connect the sensor to your own control and signal evaluation equipment according to Fig. 1.

### Signal input »Transmitter«

A signal on the input makes the wms sensor emitting a sound pulse. For this a open collector output has to earth the »transmitter« signal input for the time given in the technical data table below.

### Signal output »Echo«

The signal output »Echo« subsequently transmits all echo signals received depending on the duration as 1-bit values (echo yes/no).

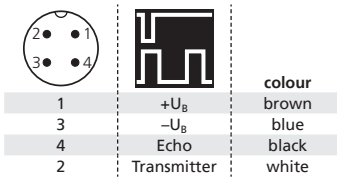
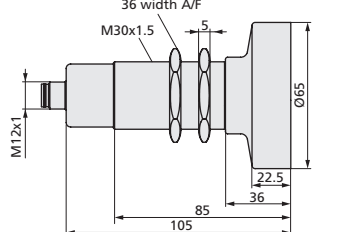
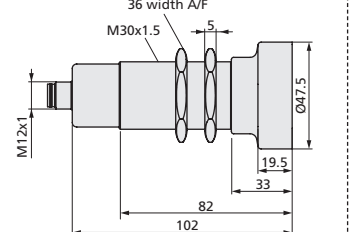
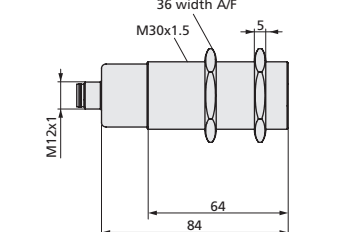
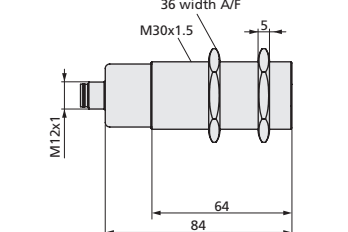
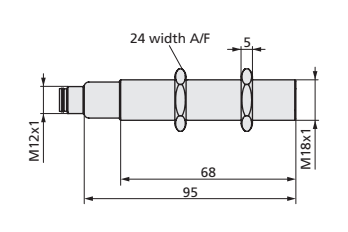
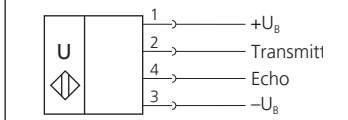

Fig. 1: Pin assignment with view onto the sensor plug and colour code of the connection cable



## Technical Data



<b>Blind zone</b>	30 mm	65 mm	200 mm	350 mm	800 mm
<b>Operating range</b>	250 mm	350 mm	1,300 mm	3,400 mm	6,000 mm
<b>Maximum range</b>	350 mm	600 mm	2,000 mm	5,000 mm	8,000 mm
<b>Transducer frequency</b>	320 kHz	400 kHz	200 kHz	120 kHz	80 kHz
<b>Resolution, sampling range</b>	0.35 mm	0.18 mm	0.18 mm	0.18 mm	0.18 mm
<b>Angle of beam spread</b>	see detection zone	see detection zone	see detection zone	see detection zone	see detection zone
<b>Reproducibility</b>	±0.15 %	±0.15 %	±0.15 %	±0.15 %	±0.15 %

**detection zones**  
 for different objects:  
 The dark grey areas represent the zone where it is easy to recognise the normal reflector (round bar). This indicates the typical operating range of the sensors. The light grey areas represent the zone where a very large reflector – for instance a plate – can still be recognised. The requirement is an optimal alignment of the sensor and reflector.  
 It is not possible to evaluate ultrasonic reflections outside this area.

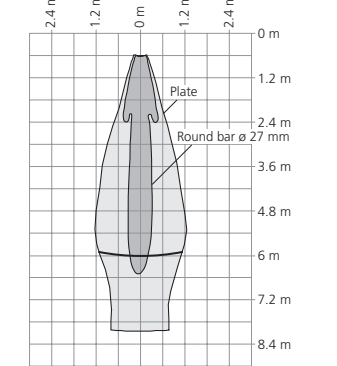
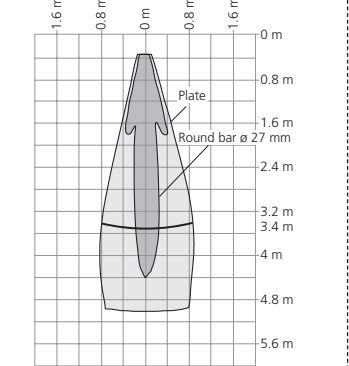
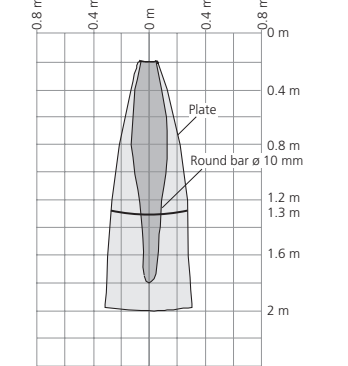
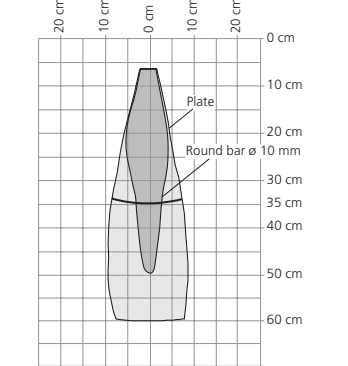
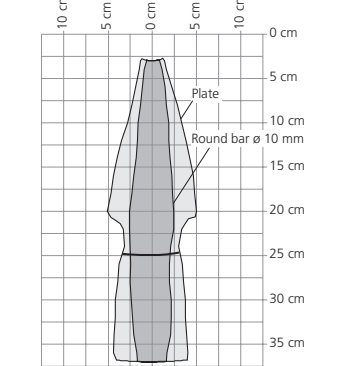

<b>Accuracy</b>	Temperature drift 0.17%/K	Temperature drift 0.17%/K	Temperature drift 0.17%/K	Temperature drift 0.17%/K	Temperature drift 0.17%/K
<b>Operating voltage U<sub>B</sub>/Voltage ripple</b>	10 to 30 V DC, reverse polarity protection/±10 %				
<b>No-load current</b>	30 mA	30 mA	30 mA	30 mA	30 mA
<b>Housing</b>	Brass sleeve, nickel-plated, plastic parts: PBT; Ultrasonic transducer: polyurethane foam, epoxy resin with glass content				
<b>Class of protection to EN 6052</b>	IP67	IP67	IP67	IP67	IP67
<b>Type of connection</b>	4-pin initiator plug, brass, nickel-plated				
<b>Operating temperature</b>	-20 to +70 °C	-20 to +70 °C	-20 to +70 °C	-20 to +70 °C	-20 to +70 °C
<b>Storage temperature</b>	-40 to +85 °C	-40 to +85 °C	-40 to +85 °C	-40 to +85 °C	-40 to +85 °C
<b>Weight</b>	80 g	200 g	200 g	260 g	320 g
<b>Signal input (Transmitter)</b>	Controlled by open collector (npn); I <sub>C</sub> ≥ 3 mA, U <sub>CE</sub> ≥ 30 V				
<b>Recommended transmitted pulse length</b>	25 µs	80 µs	150 µs	300 µs	350 µs
<b>Recommended measuring cycle time</b>	8 ms	12 ms	20 ms	40 ms	65 ms
<b>Signal output (Echo)</b>	Positive-switched (pnp), I <sub>max</sub> = 10 mA, short-circuit-proof and reverse polarity protection				
<b>Order No.</b>	wms-25/RT/HV/M18	wms-35/RT	wms-130/RT	wms-340/RT	wms-600/RT