



> SG2 MUTING Safety Light Curtains



ORIGINAL INSTRUCTIONS (ref. 2006/42/EC)

This product is covered by one or more of the following patents.

Italian Patent IT 1,363,719

Additional patents pending

Datasensing S.r.l.

Strada S. Caterina 235 - 41122 Modena - Italy

Tel: +39 059 420411 - Fax: +39 059 253973 - www.datasensing.com

“SG2 MUTING” Instruction Manual

Ed.: 03/2023

© 2012 – 2023 Datasensing S.r.l. ♦ ALL RIGHTS RESERVED. ♦ Without limiting the rights under copyright, no part of this documentation may be reproduced, stored in or introduced into a retrieval system, or transmitted in any form or by any means, or for any purpose, without the express written permission of Datasensing S.r.l. Datasensing and the Datasensing logo are trademarks of Datasensing S.r.l. Datalogic and the Datalogic logo are registered trademarks of Datalogic S.p.A. in many countries, including the U.S.A. and the E.U.

806000780 Rev. A

Compliance

European Declaration of Conformity

Hereby, Datasensing S.r.l. declares that the full text of the European Declaration of Conformity is available at: www.datasensing.com. Select the link from the downloads section of the product page.

UKCA Declaration of Conformity

Hereby, Datasensing S.r.l. declares that the full text of the UKCA Declaration of Conformity is available at: www.datasensing.com. Select the link from the downloads section of the product page.

GENERAL INFORMATION	7
1.1 General description.....	7
1.2 Package contents	8
1.3 New features compared to SG2 BASE / SG2 EXTENDED.....	9
1.4 How to choose the device.....	10
1.4.1 Detection capability.....	10
1.4.2 Height of the detection zone	11
1.4.3 Minimum installation distance	12
1.5 Typical applications.....	14
1.6 Safety information	15
2 INSTALLATION	16
2.1 Precautions to be observed for the choice and installation	16
2.2 General information on device positioning.....	17
2.2.1 Minimum distance from reflecting surfaces	18
2.2.2 Distance between homologous devices	20
2.2.3 Emitter and Receiver Orientation.....	22
2.2.4 Use of deviating mirrors.....	23
2.2.5 Controls after first installation.....	24
3 MECHANICAL MOUNTING	25
4 ELECTRICAL CONNECTIONS	27
4.1 Pin-out and configuration pin connection.....	27
4.2 Notes on connections	29
5 ALIGNMENT PROCEDURE	31
6 FUNCTIONS SETTING	33
6.1 Reset to Factory configuration.....	34
6.2 Function List.....	35
7 FUNCTIONS	36
7.1 Restart mode.....	36
7.2 Test	38
7.3 Reset.....	39
7.4 EDM	40
7.5 EDM selection.....	41
7.6 Reduction range.....	42
7.7 Muting	43
7.7.1 Muting function disable	44
7.7.2 Muting signalling devices.....	44
7.7.3 Typical Muting application and safety light curtain connection.....	44
7.7.4 Muting direction.....	45
7.7.5 Muting timeout	48
7.7.6 Partial Muting	49
7.8 Override	50
7.8.1 Override mode	51
7.8.2 Override timeout	52
8 USER INTERFACE AND DIAGNOSTICS	53
8.1 User interface.....	53
9 PERIODICAL CHECKS	56
9.1 General information and useful data.....	57
9.2 Warranty.....	57
10 DEVICE MAINTENANCE	58
10.1 Product disposal	58
11 TECHNICAL DATA	59

12	AVAILABLE MODELS	60
13	OVERALL DIMENSIONS	61
14	INCLUDED ACCESSORIES	62
14.1	Terminator cap (CVL-5196)	63
14.2	Tool for BCM configuration	63
15	ACCESSORIES.....	64
15.1	(ST-KSTD) Metal angled fixing bracket	64
15.2	(ST-KPxMP) Plastic angled fixing bracket	66
15.3	(SG-PSB) Protective stands	68
15.4	(SG-P) Plate kit for protective stands	69
15.5	(SE-S) Columns and floor stands	70
15.6	(SG-DM) Deviating mirrors	71
15.7	(TP) Test piece	73
15.8	Connection cables	74
15.9	Pigtail cables	75
15.10	(SG-LP) Laser pointer.....	76
15.11	(SE-SR2) Safety relay.....	77
15.12	77	
15.13	(CSME-03VU24-Y14) EDM relay box.....	77
15.14	(LMS) Muting lamps.....	78
15.15	Single Muting arms	79
15.16	Double Muting arms.....	81
15.17	(SG-M) Muting arms with external sensors	83
15.18	(SG-M-CB) Connection box.....	86
15.19	(SG-SRT) Connection box	88
15.20	(SG-BWS) Safety control units	89
16	GLOSSARY	90

GENERAL VIEW



Fig 1 - Safety light curtain

LED description

The microprocessor guarantees the check and the management of the beams that are sent and received through the units: the microprocessor – through some LEDs – informs the operator about the general conditions of the safety light curtain, both for settings and for diagnostics (see cfr. **USER INTERFACE AND DIAGNOSTICS page 53**).

1 GENERAL INFORMATION

1.1 GENERAL DESCRIPTION

The safety light curtains are optoelectronic multibeam devices that are used to protect working areas that, in presence of machines, robots, and automatic systems in general, can become dangerous for operators that can get in touch, even accidentally, with moving parts.

The light curtains are intrinsic safety systems used as accident-prevention protection devices and are manufactured in accordance with the international Standards in force for safety, in particular:

NORM	DESCRIPTION
EN 61496-1: 2013	Safety of machinery: electrosensitive protective equipment. Part 1: General prescriptions and tests.
EN 61496-2: 2013	Safety of machinery: electrosensitive protective equipment - Particular requirements for equipment using active optoelectronic protective devices.
EN ISO 13849-1: 2015	Safety of machinery. Safety-related parts of control systems. Part 1: General principles for design
EN 61508-1: 2010	Functional safety of electrical/electronic/programmable electronic safety-related systems. Part 1: General requirements
EN 61508-2: 2010	Functional safety of electrical/electronic/programmable electronic safety-related systems. Part 2: Requirements for electrical/electronic/programmable electronic safety-related systems
EN 61508-3: 2010	Functional safety of electrical/electronic/programmable electronic safety-related systems. Part 3: Software requirements
EN 61508-4: 2010	Functional safety of electrical/electronic/programmable electronic safety-related systems. Part 4: Definitions and abbreviations
EN 62061:2005/A2: 2015	Safety of machinery. Functional safety of electrical/ electronic/programmable electronic safety-related control systems.

The device, consisting of one emitter and one receiver contained inside aluminium profiles, generates infrared beams that detect any opaque object positioned within the light curtain detection field.

The emitter and the receiver are equipped with the command and control functions.

The connections are made through one or more connectors as specified in cfr. **ELECTRICAL CONNECTIONS page 27**.

The synchronisation between the emitter and the receiver takes place optically, i.e. no electrical connection between the two units is required.

The microprocessor guarantees the check and the management of the beams that are sent and received through the units: the microprocessor – through some LEDs – informs the operator about the general conditions of the safety light curtain (cfr. **USER INTERFACE AND DIAGNOSTICS page 53**).

The receiver is the main controller for all functions. It monitors all safety actions in case of failure and performs general functions as well.

During installation, an user interface facilitates the alignment of both units (cfr. **ALIGNMENT PROCEDURE page 31**).

As soon as an object, or a limb or the operator's body accidentally interrupts one or some of the infrared beams sent by the emitter, the receiver immediately opens the OSSD outputs or trigger Safety State over connected safety Fieldbus.

Some parts or sections of this manual containing important information for the user or installing operator are preceded by a note:



Notes and detailed descriptions about particular characteristics of the safety devices in order to better explain their functioning. Special instructions regarding the installation process.

This manual contains all the information necessary for the selection and operation of the safety devices.

However, specialised knowledge not included in this technical description is required for the planning and implementation of a safety light curtain on a power-driven machine.

As the required knowledge may not be completely included in this manual, we suggest the customer to contact Datasensing Technical Service for any necessary information relative to the functioning of the light curtains and the safety rules that regulate the correct installation (cfr. **USER INTERFACE AND DIAGNOSTICS page 53**).

1.2 PACKAGE CONTENTS

Package contains the following objects:

- Receiver (RX)
- Emitter (TX)
- Quick Guide of safety light curtain
- Periodical checklist and maintenance schedule
- Mini-DVD with instruction manual and other documents
- 4 angled fixing brackets and specific fasteners
- 2 additional angled fixing brackets for models with heights included between 1200 and 1800 mm

1.3 NEW FEATURES COMPARED TO SG2 BASE / SG2 EXTENDED

With respect to SG2 BASE / SG2 EXTENDED series, safety light curtains of SG2 MUTING series have some new important features:

- Higher operating distance
- New profile compatible with SE accessories
- Advanced alignment function for receiver and transmitter units
- Muting function
- Partial muting
- Override
- Override status
- Reduction Range
- Null dead zone (the controlled height of the light curtain is equivalent to the light curtain's height)
- Basic configuration with push-buttons (BCM)

1.4 HOW TO CHOOSE THE DEVICE

There are at least three different main characteristics that should be considered when choosing a safety light curtain, after having evaluated the risk assessment.

1.4.1 Detection capability

The detection capability (or resolution) of the device is the minimum diameter that an opaque object must have in order to obscure at least one of the beams that constitute the detection zone and to actuate the sensing device.

The resolution is related to the part of the body to be protected.

R=30 mm

Hand protection

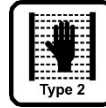

As shown in **Fig 2 - page 10**, the resolution only depends on the geometrical characteristics of the lenses, diameter and distance between centres, and is independent of any environmental and operating conditions of the safety light curtain.

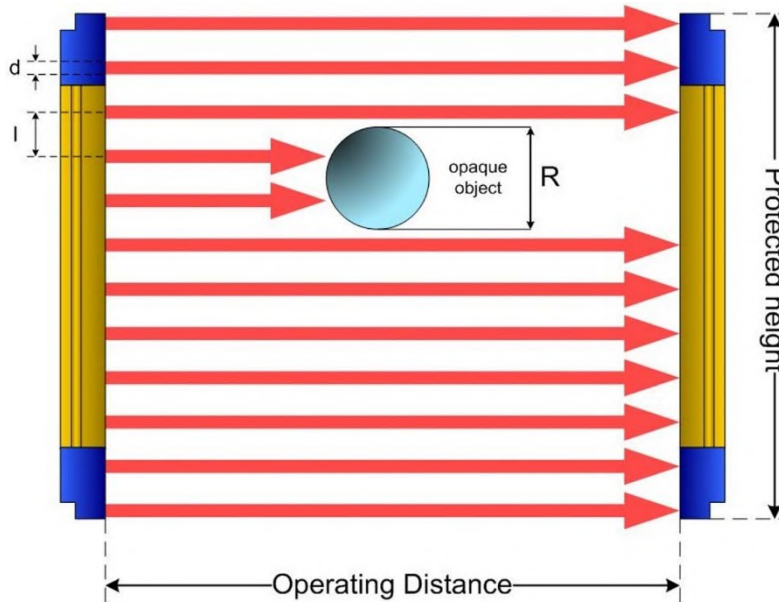

Fig 2 - Detection capability

The resolution value is obtained applying the following formula:

$$R = l + d$$

where:

l=Interaxes between two adjacent optics

d=Lens diameter

1.4.2 Height of the detection zone

The controlled height is the height protected by the safety light curtain.

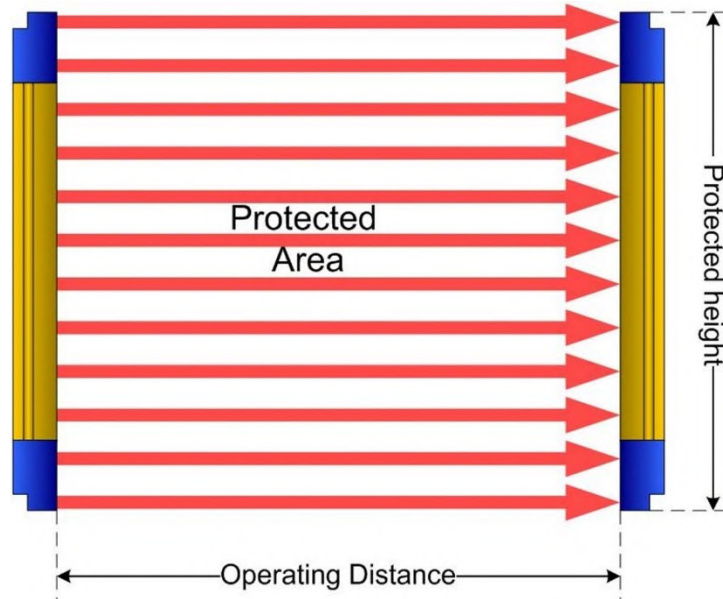

Fig 3 - Detection Zone

	MODEL	Controlled height Hp (mm)
	SG2-30-030-OO-W	300
	SG2-30-045-OO-W	450
	SG2-30-060-OO-W	600
	SG2-30-075-OO-W	750
	SG2-30-090-OO-W	900
	SG2-30-105-OO-W	1050
	SG2-30-120-OO-W	1200
	SG2-30-135-OO-W	1350
	SG2-30-150-OO-W	1500
	SG2-30-165-OO-W	1650
	SG2-30-180-OO-W	1800

1.4.3 Minimum installation distance

The safety device must be positioned at a specific safety distance (**Fig 4 - page 12**).

This distance must ensure that the dangerous area cannot be reached before the dangerous motion of the machine has been stopped by the Safety Control System.

The safety distance depends on 4 factors, according to the EN ISO 13855 Standard:

- Response time of the ESPE (the time between the effective beam interruption and the opening of the OSSD contacts)
- Machine stopping time including Safety Control System computing and actuating time if present.
- ESPE resolution
- Approaching speed of the object to be detected

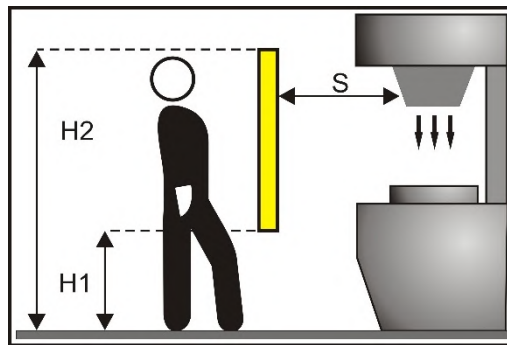

Fig 4 - Installation distance (vertical positioning)

The following formula is used for the calculation of the safety distance:

$$S = K (t1 + t2) + C$$

where:

- S = Minimum safety distance in mm
- K = Speed of the object, limb or body approaching the dangerous area in mm/sec
- t1 = Response time of the ESPE in seconds (see cfr. **TECHNICAL DATA page 59**)
- t2 = Machine stopping time in seconds (including the Safety Control System)
- C = Additional distance based on the possibility to insert the body or one of body parts inside the dangerous area before the protective device trips.
 C=8 (R -14) for devices with resolution ≤ 40 mm
 C=850 mm for devices with resolution > 40 mm
- R = Resolution of the system



K value is:
2000 mm/s if the calculated value of S is ≤ 500 mm
1600 mm/s if the calculated value of S is > 500 mm

When devices with > 40 mm resolution are used, the height of the top beam has to be ≥ 900 mm (H2) from machine supporting base while the height of the bottom beam has to be ≤ 300 mm (H1).

If the safety light curtain must be mounted in a horizontal position (**Fig 5 - page 13**) the distance between the dangerous area and the most distant optical beam must be equal to the value calculated using the following formula:

$$S = 1600 \text{ mm/s} (t_1 + t_2) + 1200 - 0,4 H$$

where:

- S = Minimum safety distance in mm.
- t1 = Response time of the ESPE in seconds (cfr. **TECHNICAL DATA page 59**)
- t2 = Machine stopping time in seconds (including the Safety Control System)
- H = Beam height from ground; this height must always be less than 1,000 mm.

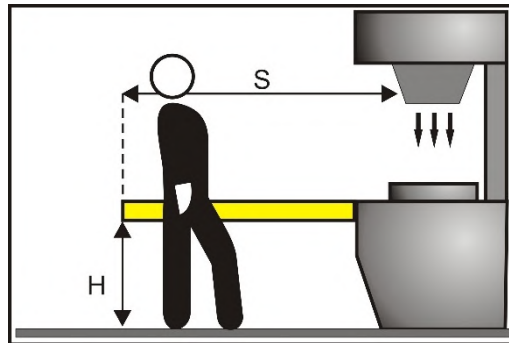

Fig 5 - Installation distance (horizontal positioning)

Practical examples

Let's suppose to have a light curtain with height = 600 mm

To calculate the distance of the device from the ESPE, in a vertical position, the following formula is used:

$$S = K \cdot T + C$$

where:

- S = Minimum safety distance in mm.
- t1 = ESPE response time
- t2 = Machine total stopping time (Including safety control system).
- T = (t1 + t2) Overall system stopping performance
- C = 8 * (R - 14) for devices with resolution ≤ 40 mm
- R = Resolution of the system

In all cases, if K = 2000mm/sec then S > 500 mm.

Distance will have then to be recalculated using K = 1600 mm/sec.



The reference standard is EN ISO 13855 "Safety of machinery - Positioning of safeguards with respect to the approach speeds of parts of the human body".
The following information is to be considered as indicative and concise.
For correct safety distance please refer to complete standard EN ISO 13855.

1.5 TYPICAL APPLICATIONS

The SG2 MUTING safety light curtains are used in all automation fields where the control and protection of access to dangerous zones is necessary.

In particular they are used to stop the moving mechanical parts of:

- Automatic machines
- Packaging machines, handling machines, storing machines
- Wood working machines, glass working machines, ceramics working machines, etc.
- Automatic and semi-automatic assembly lines
- Automatic warehouses
- Presses, punching machines, benders and cutters

In food industry applications, DATASENSING Technical Service has to verify the compatibility of the material of the safety light curtain housing with any chemical agents used in the production process.

The following pictures show some main applications.

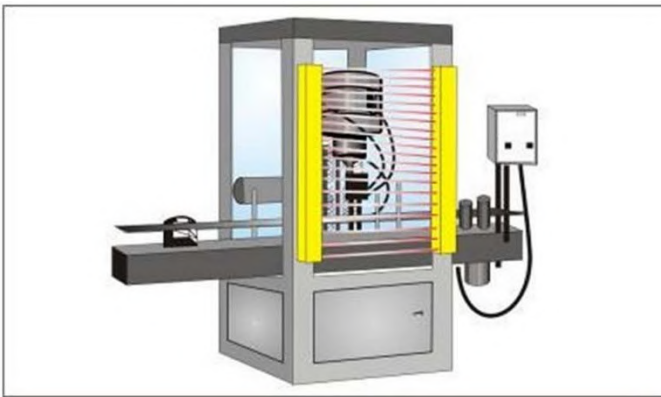

Fig 6 - Automatic packaging machines



Fig 7 - Presses and punching machines

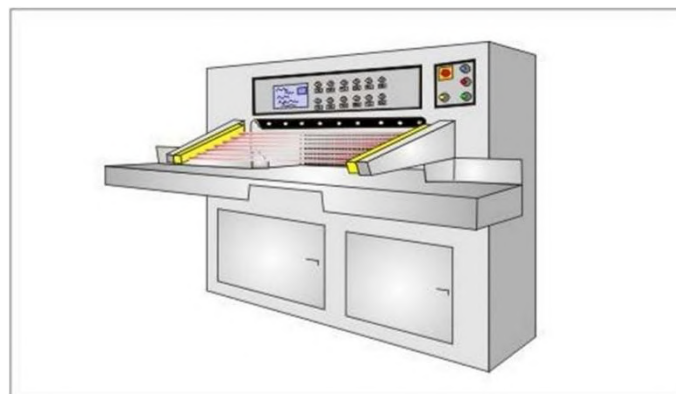

Fig 8 - Benders and cutters

1.6 SAFETY INFORMATION



For a correct and safe use of the safety light curtains, the following points must be observed:

- The stopping system of the machine must be electrically controlled.
- This control system must be able to stop the dangerous movement of the machine within the total machine stopping time T as per paragraph **Minimum installation distance page 12** and during all working cycle phases.
- Mounting and connection of the safety light curtain must be carried out by qualified personnel only, according to the indications included in the special sections (refer to sections **INSTALLATION page 16**, **MECHANICAL MOUNTING page 25**, **ELECTRICAL CONNECTIONS page 27**, **ALIGNMENT PROCEDURE page 31**) and in the applicable standards.
- The safety light curtain must be securely placed in a particular position so that access to the dangerous zone is not possible without the interruption of the beams (refer section **INSTALLATION page 16**).
- The personnel operating in the dangerous area must be well trained and must have adequate knowledge of all the operating procedures of the safety light curtain.
- The TEST button must be located outside the protected area because the operator must check the protected area during all Test operation.



Please carefully read the instructions for the correct functioning before powering the light curtain on.

2 INSTALLATION

2.1 PRECAUTIONS TO BE OBSERVED FOR THE CHOICE AND INSTALLATION



Make sure that the protection level assured by the light curtain device is compatible with the real danger level of the machine to be controlled, according to EN ISO 13849-1: 2015 or EN 62061:2005/A2: 2015.

- Use only matched emitter and receiver pairs with same serial no.
- The outputs (OSSD) of the ESPE must be used as machine stopping devices and not as command devices.
- The machine must have its own START command.
- The dimension of the smallest object to be detected must be larger than the resolution level of the device.
- The ESPE must be installed in an environment complying with the characteristics indicated in **TECHNICAL DATA page 59**.
- The ESPE must not be installed close to strong and/or flashing light sources, in particular close to the front window of receiving unit.
- The presence of intense electromagnetic disturbances could affect device's correct operation.
- This condition shall be carefully assessed with the advice of DATASENSING Technical Service.
- The operating distance of the device can be reduced in presence of smog, fog or airborne dust.
- A sudden change in environment temperature, with very low minimum peaks, can generate a small condensation layer on the lenses and thus jeopardize correct operation.

2.2 GENERAL INFORMATION ON DEVICE POSITIONING

The safety light curtain should be carefully positioned in order to provide the necessary protection. Access to the dangerous area must only be possible by passing through the protecting safety light beams.



Fig 9 - page 17 shows some examples of possible access to the machine from the top and the bottom sides. These situations may be very dangerous and so the installation of the safety light curtain at sufficient height in order to completely cover the access to the dangerous area (Fig 10 - page 17) becomes necessary.

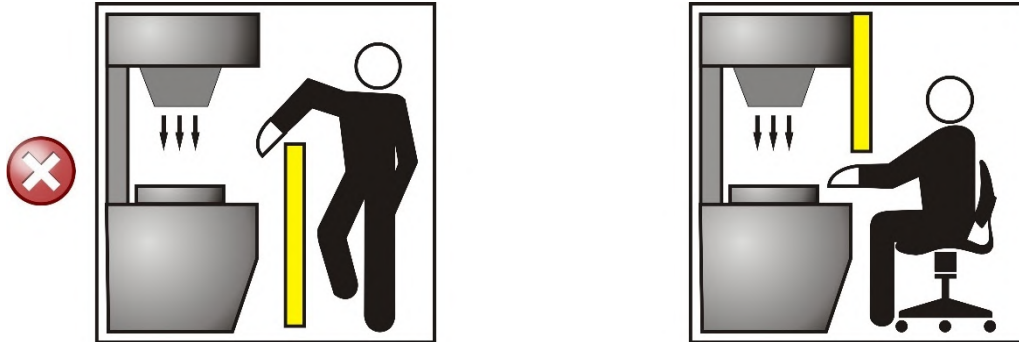

Fig 9 - Wrong light curtain positioning



Fig 10 - Correct light curtain positioning



If the operator is able to enter in the dangerous area, an additional mechanical protection must be mounted to prevent the access.

Under standard operating conditions, machine starting must not be possible while operators are inside the dangerous area.

Where it is not possible to install safety light curtain very near to the dangerous zone, a second light curtain must be mounted in a horizontal position in order to prevent any lateral access, as shown in Fig 12 - page 17.

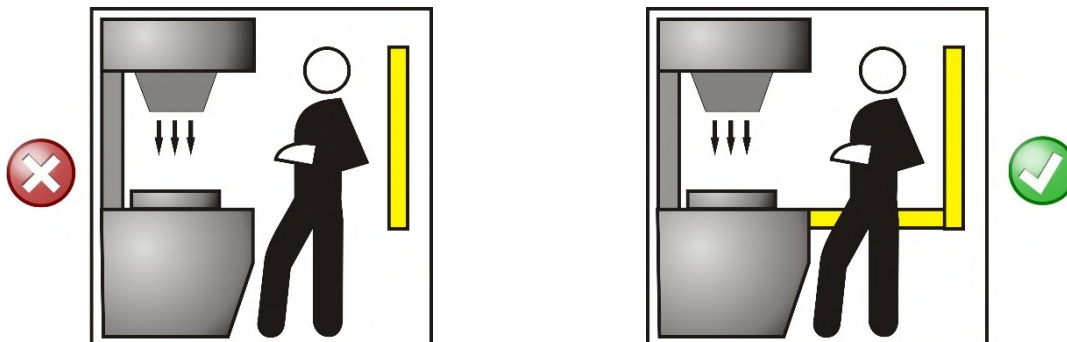

Fig 11 - Wrong light curtain positioning

Fig 12 - Correct light curtain positioning

2.2.1 Minimum distance from reflecting surfaces

Reflecting surfaces placed near the light beams of the safety device (over, under or laterally) can cause passive reflections. These reflections can affect the recognition of an object inside the controlled area. Moreover, if the RX receiver detects a secondary beam (reflected by the side-reflecting surface) the object might not be detected, even if the object interrupts the main beam.

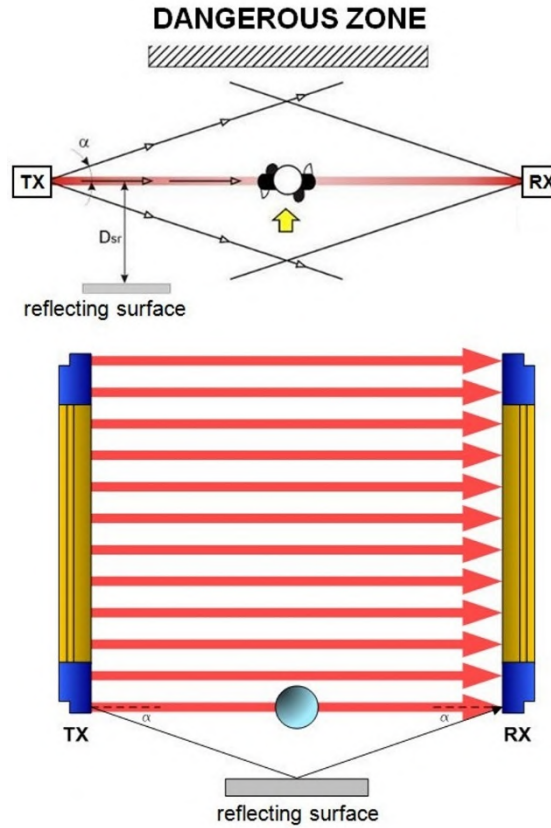

Fig 13 - Distance from reflecting surfaces

It is important to position the safety light curtain according to the minimum distance from reflecting surfaces.

The minimum distance depends on:

- operating distance between emitter (TX) and receiver (RX);
- real aperture angle of ESPE (EAA); especially:

for ESPE Type 2 EAA = 10° ($\alpha = \pm 5^\circ$)

Diagram of **Fig 14 - page 19** shows the minimum distance from the reflecting surface (Dsr), based on the operating distance:

ESPE Type 2

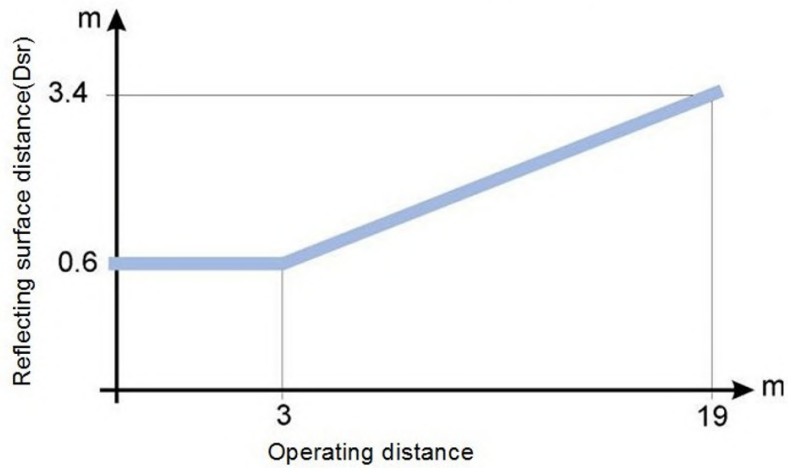

Fig 14 - Minimum distance from reflective surface

The formula to get Dsr is the following:

For ESPE Type 2:

$Dsr (m) = 0.6$

for operating distance < 3 m

$Dsr (m) = \text{operating distance (m)} \times \text{tg } 2a$

for operating distance \geq 3 m

2.2.2 Distance between homologous devices

The following graphic shows the distance from the interfering devices (D_{do}) according to the operating distance (D_{op}) of the couple (TXA – RXA).

If different safety devices have to be installed in adjacent areas, the emitter of one device must not interfere dangerously with the receiver of the other device.

The TXB interfering device must be positioned outside a minimum D_{do} distance from the TXA – RXA emitter-receiver couple axis.

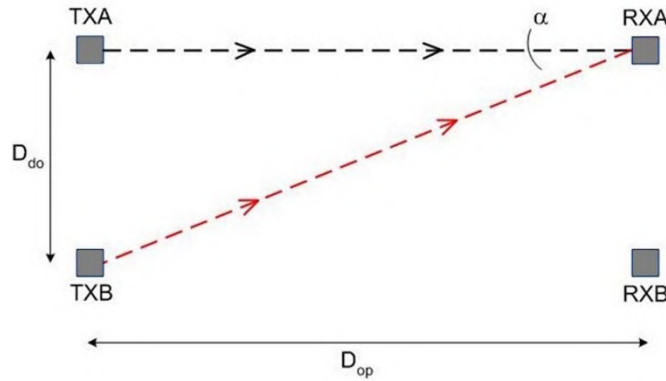

Fig 15 - Distance between homologous devices

This minimum D_{do} distance depends on:

- the operating distance between emitter (TXA) and receiver (RXA)
- the effective aperture angle of the ESPE (EAA)

The following graphic shows the distance from the interfering devices (D_{do}) according to the operating distance (D_{do}) of the couple (TXA – RXA).

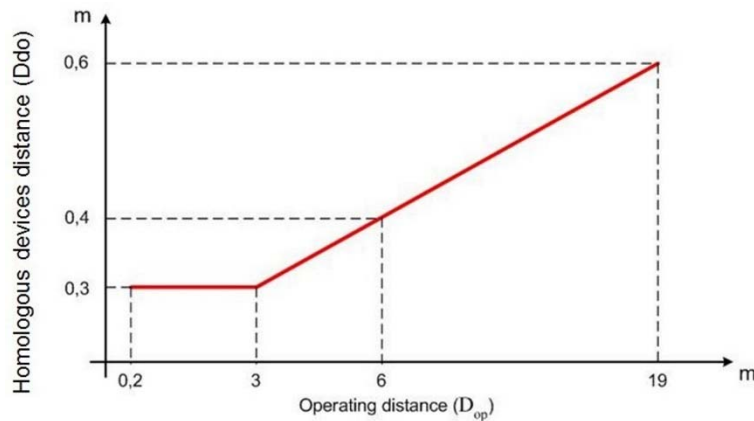

Fig 16 - ESPE Type2

The following table shows, for convenience, the values of the minimum installation distances relative to some operating distances:

Operating distance (m)	Minimum installation distance (m)
3	0,3
6	0,4
10	0,5
19	0,6



The interfering device (TXB) must be positioned at the same D_{do} distance, calculated as shown above, even if closer to TXA respect to RXA. Installation precautions have to be taken to avoid interference between homologous devices. A typical situation is represented by the installation areas of several adjacent safety devices aligned one next to the other, for example in plants with different machines.

The figure provides two examples:

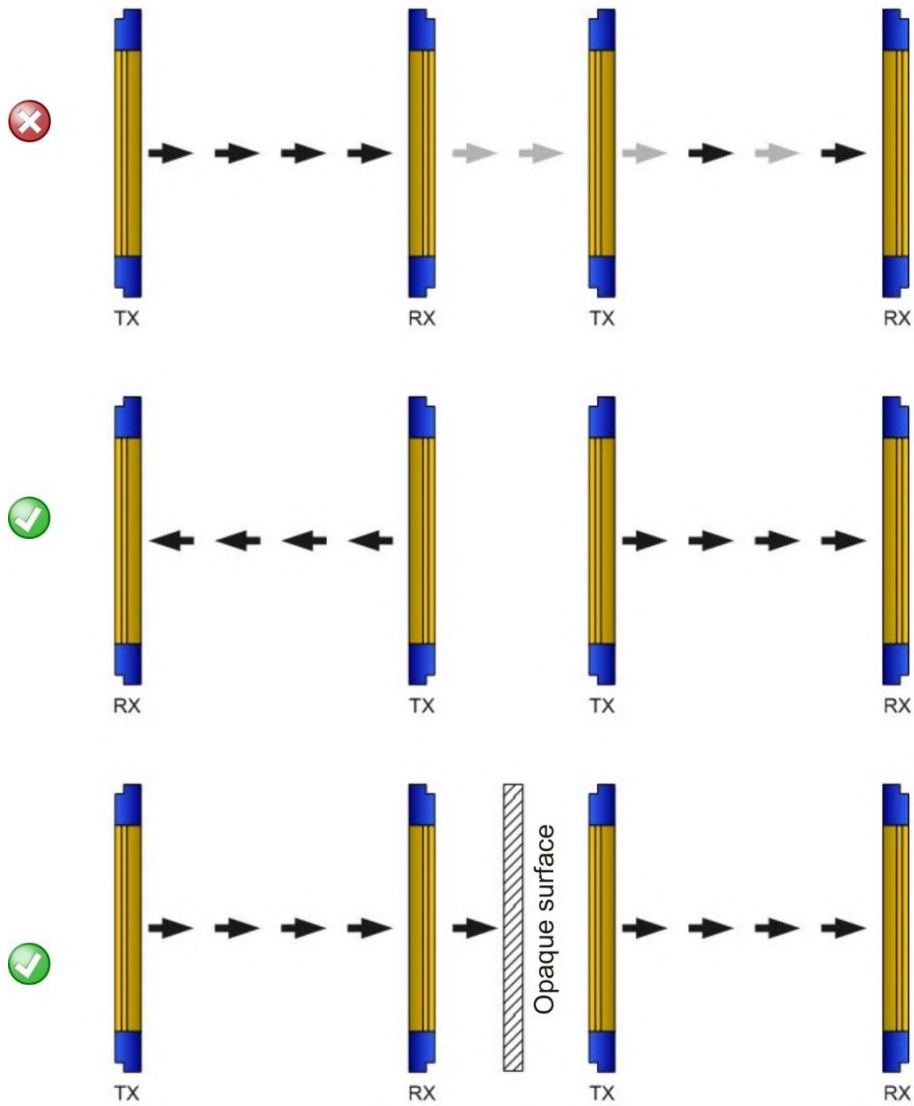

Fig 17 - Recommended positioning for homologous devices



If two light curtains have to be mounted near each other as reported in the first example of Fig 17 - page 21.

2.2.3 Emitter and Receiver Orientation

The two units shall be assembled parallel each other, with the beams arranged at right angles with the emission and receiving surface, and with the connectors pointing to the same direction.

The configurations shown in the figure must be avoided:

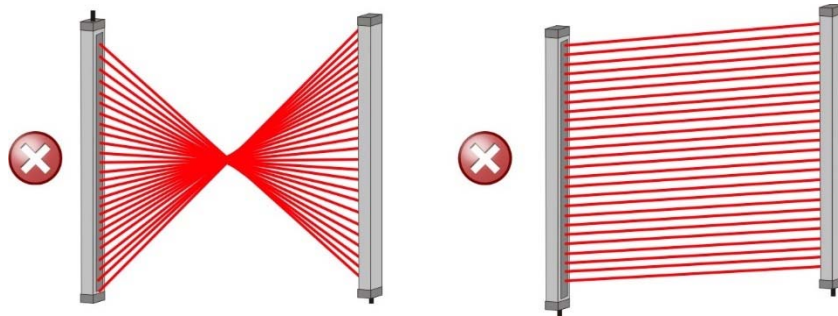

Fig 18 - Wrong light curtain TX-RX orientations

2.2.4 Use of deviating mirrors

The control of any dangerous area, with several but adjacent access sides, is possible using only one safety device and well-positioned deviating mirrors.

The figure shows a possible solution to control two different access sides, using one mirror placed at 45° with respect to the beams.

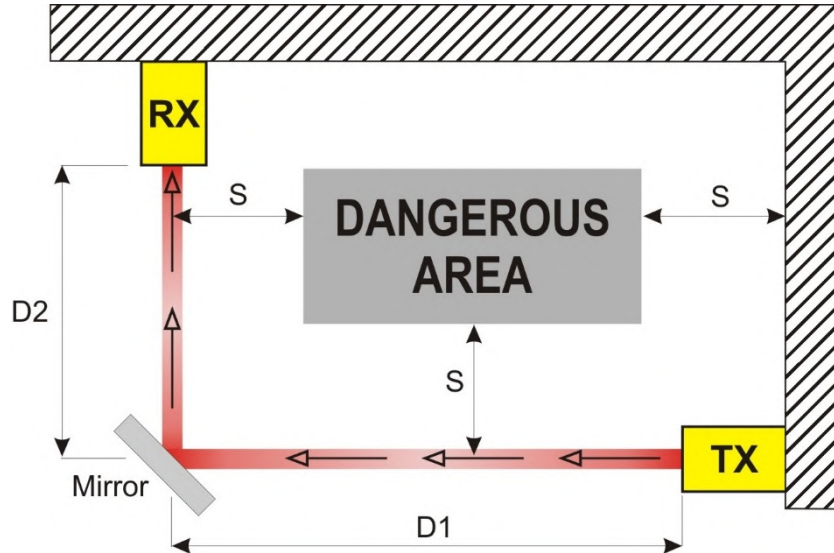

Fig 19 - Use of deviating mirrors

The operator must respect the following precautions when using the deviating mirrors:

- The alignment of the emitter and the receiver can be a very critical operation when deviating mirrors are used. Even very small displacements of the mirror is enough to lose alignment.
- The use of DATASENSING laser pointer accessory is recommended under these conditions.
- The minimum safety distance (S) must be respected for each single section of the beams.
- The effective operating range decreases by about 20% by using only one deviating mirror.

The following table shows estimated operating distances relating to the number of mirrors used.

Number of mirrors	Operating Distance
0	20 m
1	16 m

- The presence of dust or dirt on the reflecting surface of the mirror causes a drastic reduction in the range.

2.2.5 Controls after first installation

The control operations to carry-out after the first installation and before machine start-up are listed hereinafter. The controls must be carried-out by qualified personnel, either directly or under the strict supervision of the person in charge of machinery Safety.

Verify that:

- L'ESPE rimanga in stato di SICUREZZA, e intercetti i raggi lungo la zona protetta utilizzando l'apposito test piece (TP-14 o TP-30), secondo lo schema di **Fig 20 - page 24**.

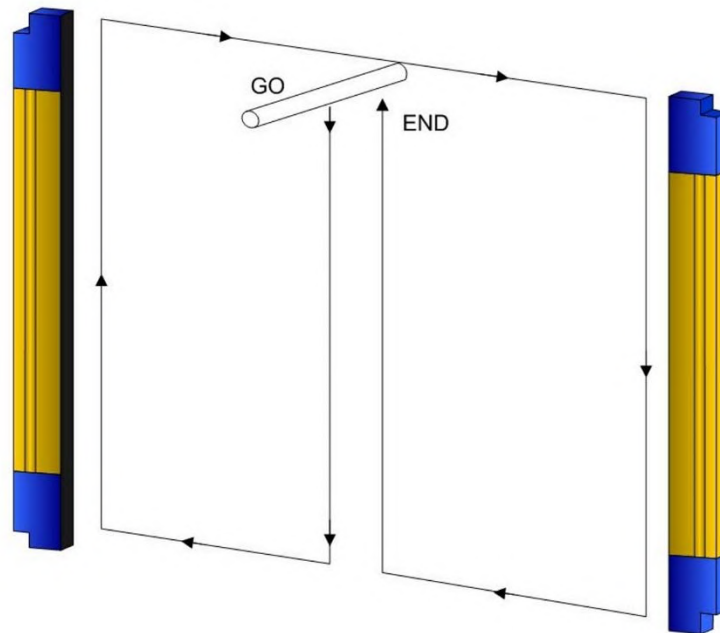

Fig 20 - Path of the test piece

- ESPE has to be correctly aligned, press slightly on the product side in both directions the red LED must not turn on
- The activation of the TEST function (on TX side) causes the opening of the OSSD outputs (red LED, OSSD on RX side, ON and controlled machine stop)
- The response time at machine STOP, including the ESPE and machine response times, must be included in the limits defined in the calculation of the safety distance (refer to chapter **INSTALLATION page 16**).
- The safety distance between the dangerous parts and ESPE must comply with the requirements indicated in chapter **INSTALLATION page 16**.
- A person must not access or remain between ESPE and the dangerous parts of the machine
- Access to the dangerous areas of the machine must not be possible from any unprotected area
- ESPE must not be disturbed by external light sources, ensuring that it remains in NORMAL OPERATION condition for at least 10-15 minutes and, placing the specific test piece in the protected area, in the SAFE state for the same period.
- Verify the correspondence of all the accessory functions, activating them in the different operating conditions.

3 MECHANICAL MOUNTING

The emitting (TX) and receiving (RX) units must be installed with the relevant sensitive surfaces facing each other. The connectors must be positioned on the same side and the distance must be included within the operating range of the model used (see cfr. **TECHNICAL DATA** page 59).

The two units must be positioned the most aligned and parallel possible.

The next step is the fine alignment, as shown in chapter **ALIGNMENT PROCEDURE** page 31.

Outfit angled fixing brackets kit, for units mounting, must be used as described below (**Fig 21 - page 25**).

Adjustable supports for adjusting unit inclinations around the axes are available on request (see cfr. **ACCESSORIES** page 64).

To mount the angled fixing brackets kit, place the threaded pins metallic insert into the dedicated side seat of the terminator cap side light curtain closing cap; slide the insert towards the metallic drawn profile groove.

Fix the bracket against the profile by tightening the M5 hexagonal nuts. It's possible to slide the bracket group along their dedicated rail and fix it once again just working on the above mentioned nuts.

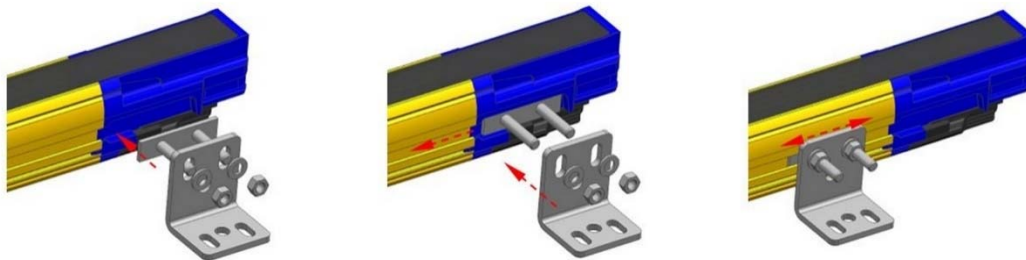

Fig 21 - Fixed brackets mounting procedure

In case of applications with particularly strong vibrations, vibration dampers, together with mounting brackets, are recommended to reduce the impact of the vibrations.



Fig 22 - Anti-vibration dampers

The recommended mounting positions according to the light curtain length are shown in **Fig 23 - page 26** and in the following table.

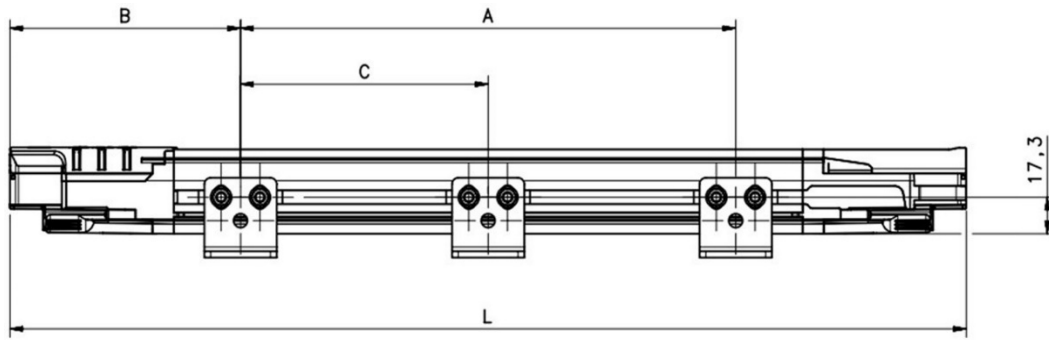

Fig 23 - Light curtain dimensions

MODEL	L (mm)	A (mm)	B (mm)	C (mm)
SG2-30-030-OO-W	306.3	86.3	110	-
SG2-30-045-OO-W	456.3	236.3	110	-
SG2-30-060-OO-W	606.2	306.2	150	-
SG2-30-075-OO-W	756.2	406.2	175	-
SG2-30-090-OO-W	906.1	506.1	200	-
SG2-30-105-OO-W	1056.1	606.1	225	-
SG2-30-120-OO-W	1206	966	150	453
SG2-30-135-OO-W	1356	1066	175	503
SG2-30-150-OO-W	1505.9	1166	200	553
SG2-30-165-OO-W	1655.9	1266	225	603
SG2-30-180-OO-W	1805.8	1366	250	652.9

4 ELECTRICAL CONNECTIONS

4.1 PIN-OUT AND CONFIGURATION PIN CONNECTION

All electrical connections to the emitting and receiving units are made through some particular cables; these cables are composed of a rectangular 18 pin connector on light curtain side and M12 male connector(s) on the other side. The Muting cable allows to have on the receiving unit one M12 12-pole connector and one M12 5-pole connector. The Blanking cable allows to have on the receiving unit one M12 12-pole connector. The emitting unit has one M12 5-pole connector (both in Muting and Blanking mode). The cables have to be connected on the bottom side of the light curtains (leds and push button side) by removing the white cap that is present.

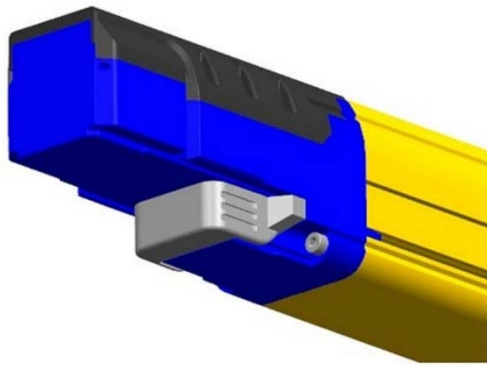

Fig 24 - Conessioni

Take care that the terminator cap (CVL-5196, see cfr. **INCLUDED ACCESSORIES page 62**) is connected on the top side of the light curtains.

If this connection misses, Master and Slave units go in critical Communication failure.

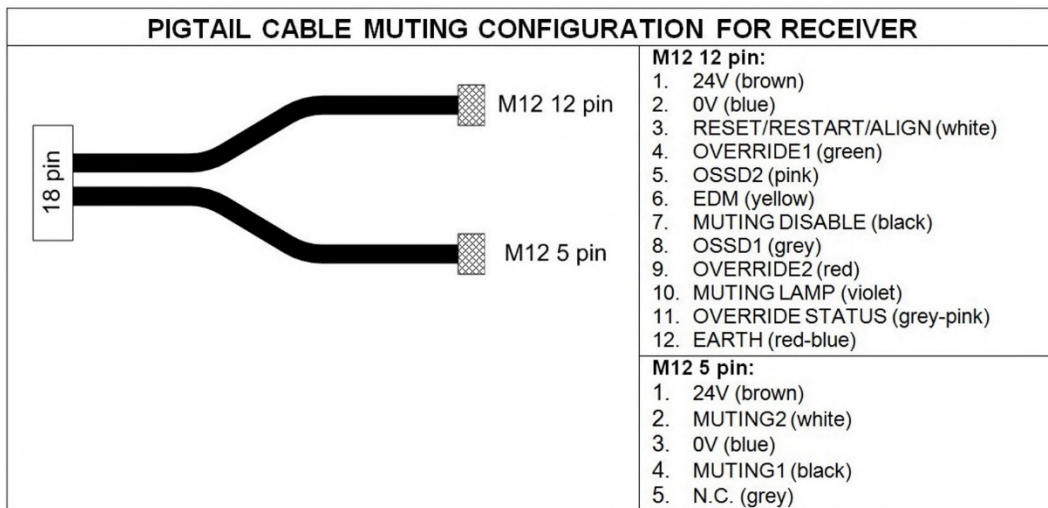

Fig 25 - Pigtail cable - Muting configuration for receiver RX (CS-R1-75-B-002)

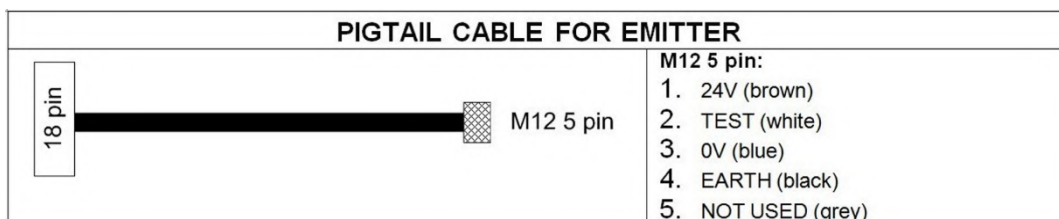

Fig 26 - Pigtail cable - configuration for emitter TX (CS-G1-50-B-002)

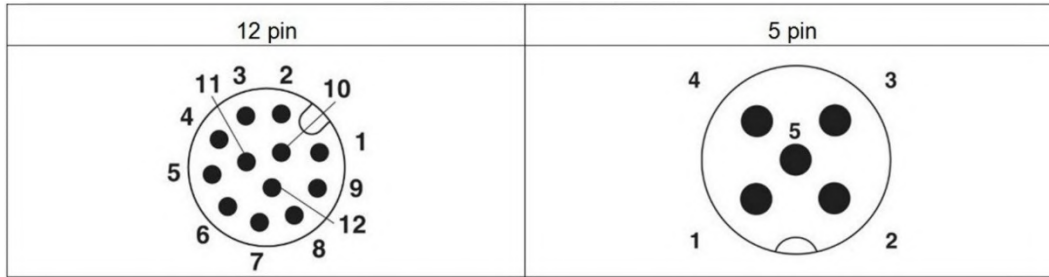

Fig 27 - M12 Connectors pinout

MUTING CONFIGURATION		
LINE	LAYOUT CONNECTION	BEHAVIOUR
RESET	IN line 24Vdc	active on high level in failure lockout
RESTART	IN line 24Vdc	active on high level at runtime
ALIGNMENT	IN line 24Vdc	active on high level at startup
OVERRIDE 1	IN line 24Vdc	active on high level at runtime
OVERRIDE 2	IN line 24Vdc	active on low level at runtime
EDM	SEE PAR. 7.4 FOR CONNECTIONS	must be ossds antivalent at runtime with edm enabled
MUTING DISABLE	IN line 24Vdc	Muting disabled on high level at runtime

Fig 28 - Muting configuration

MUTING CONFIGURATION RECEIVER		
LINE	LAYOUT CONNECTION	BEHAVIOUR
OSSD1 / OSSD 2		high level = free path low level = object detection
OVERRIDE STATUS		high level = override function active low level = override function not active NOTE: at startup there are fluctuations on this line not concerning the override activation
MUTING LAMP		open collector sinks on Muting activation.
MUTING1/MUTING2	IN line 24Vdc	active on high level at runtime
EARTH		connect directly to earth

Fig 29 - Muting configuration receiver

EMITTER		
LINE	LAYOUT CONNECTION	BEHAVIOUR
TEST	IN line 24Vdc	active on high level at runtime
EARTH		connect directly to earth

Fig 30 - Configuration emitter

4.2 NOTES ON CONNECTIONS

For the correct operation of the safety light curtains, the following precautions regarding the electrical connections have to be respected:

- Do not place connection cables in contact with or near high-voltage cables and/or cable undergoing high current variations (e.g. motor power supplies, inverters, etc.).
- **Do not connect in the same multi-pole cable the OSSD wires of different light curtains.**
- The TEST wire must be connected through a N.O. button to the supply voltage of the ESPE.



The TEST button must be located in such a way that the operator can check the protected area during any test.

The RESET/RESTART/ALIGN button must be located in such a way that the operator can check the protected area during any reset operation.

- The device is already equipped with internal overvoltage and overcurrent suppression devices.
- **The use of other external components is not recommended.**

Example: connection to the safety relay SE-SR2

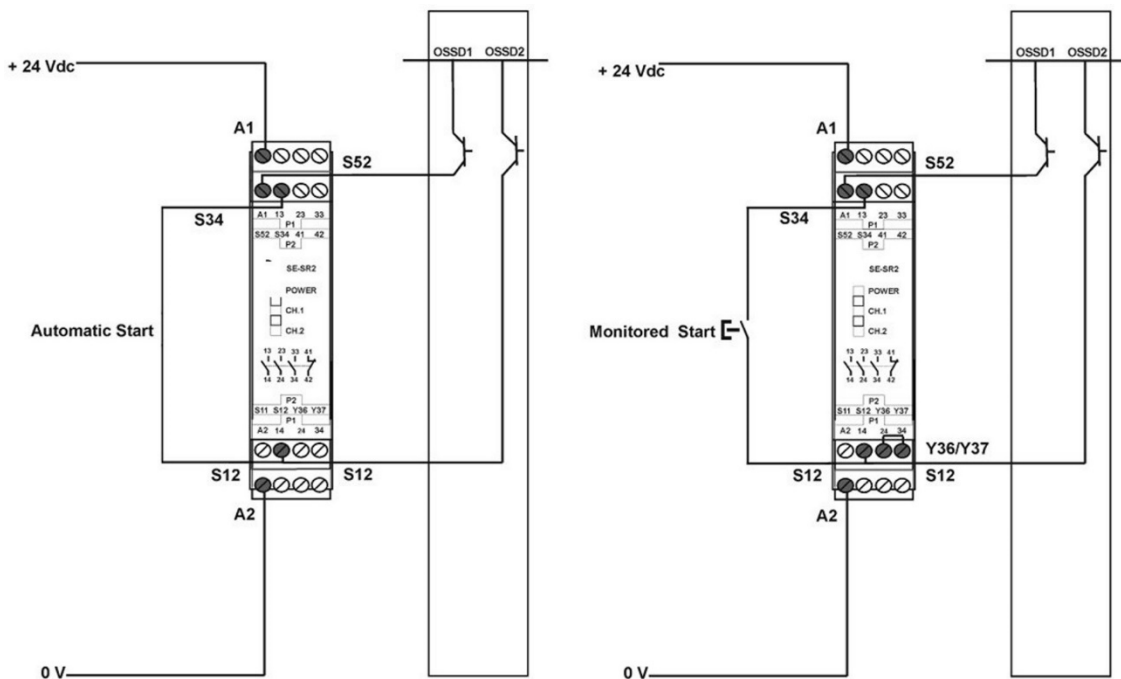

Fig 31 - Connection to SE-SR2 Safety Relais

The figures show the connection between the safety light curtains and the safety relay of the SE-SR2 series functioning in the Automatic Restart mode (left side) and Manual Restart with monitoring (right side).

- Do not use varistors, RC circuits or LEDs in parallel at relay inputs or in series at OSSD outputs.
- The OSSD1 and OSSD2 safety contacts cannot be connected in series or in parallel, but can be used separately, conforming to the plant's safety requirements.
- If one of these configurations is erroneously used, the device enters into the output failure condition (see cfr. **USER INTERFACE AND DIAGNOSTICS page 53**).

- Connect both OSSDs to the device to control.
- Failure to connect an OSSD to the activating device jeopardizes the system safety degree that the light curtain has to control.

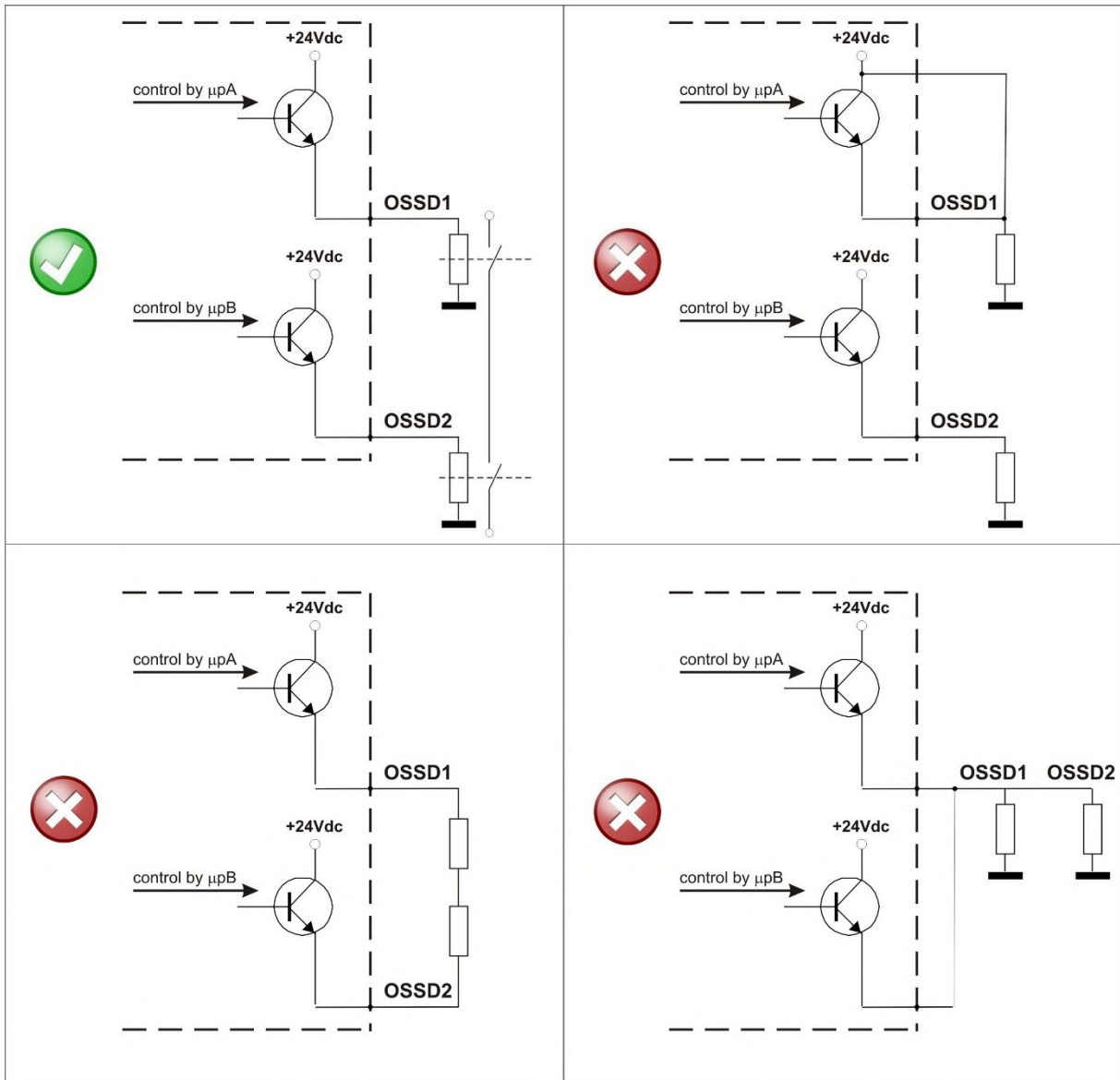

Fig 32 - OSSDs connection

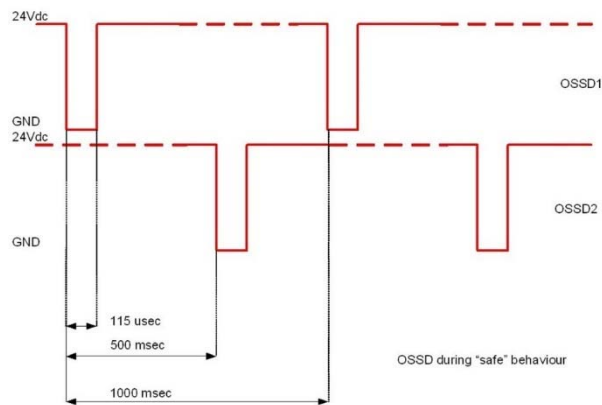

Fig 33 - Behaviour of OSSDs

5 ALIGNMENT PROCEDURE

The alignment between the emitting and the receiving units is necessary to obtain the correct operation of the light curtain.

A good alignment prevents outputs instability caused by dust or vibrations.

The alignment is perfect if the optical axes of the first and the last emitting unit's beams coincide with the optical axes of the corresponding elements of the receiving unit.

Since the light curtain has two beams for the synchronization, let's call SYNC1 the sync beam at the bottom, the first beam of the array, and SYNC2 the sync beam on the opposite part of the light curtain, the last beam of the array.

The figure shows that the first beam is located at the bottom edge of the light curtain, near to led display.

The last beam is at the opposite near the terminator cap. These two beams are the synchronization beams too.

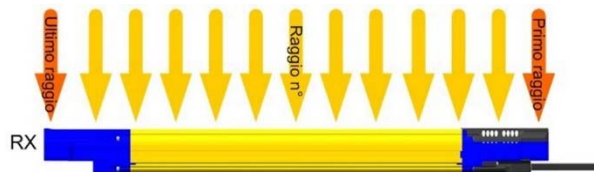

Fig 34 - Description of the beams

The Alignment function can be activated by simply keeping pressed the external normally open push-button linked to RESET/RESTART/ALIGN input (pin 3 of M12-12 poles – RX side) at start-up until the second led (red) begins to blink indicating the activation of the Alignment function, as shown in the following timing diagram. When a good state of alignment is reached a power OFF and a power ON operation carry back the ESPE in normal operation.

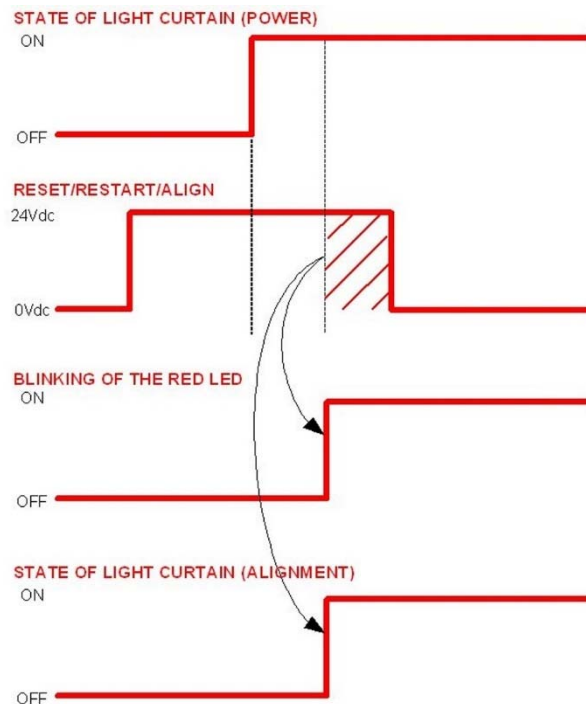

Fig 35 - Alignment timings

In Alignment Mode ESPE is always in Safe State and the OSSDs are kept OFF.

The state of alignment is estimated from RX unit by reading the received signal level of each beam compared on 4 factory established thresholds. First and last beams received level get some more weight.

In alignment mode user interface informs the user about quality and level of alignment:

Keep the receiver in a steady position and set the emitter until the yellow SYNC1 LED is OFF. This condition shows the effective alignment of the first synchronisation beam

Rotate the emitter, pivoting on the lower optics axis, until the yellow SYNC2 LED is OFF

Delimit the area in which alignment is good and steady through some micro adjustments - for the first and then for the second unit – in order to have the maximum alignment LEVEL () and then place both units in the centre of this area

Fix the two units firmly using brackets. Verify that the LEVEL on the RX unit is as high as possible and beams are not interrupted, then verify that all LEVEL Led turn OFF if even one single beam is interrupted. This verification shall be made with the special cylindrical “Test Piece” having a size suitable to the resolution of the device used (see cfr. **Controls after first installation page 23**).

Switch-off and on the device in standard operating mode. The alignment level is monitored also during the device normal operation with the same display (see cfr. **User interface page 53**). Once the light curtain has been aligned and correctly fastened, the signal display is useful both to check the alignment and show a change in the environmental conditions (occurrence of dust, light disturbance and so on) via signal level monitoring.









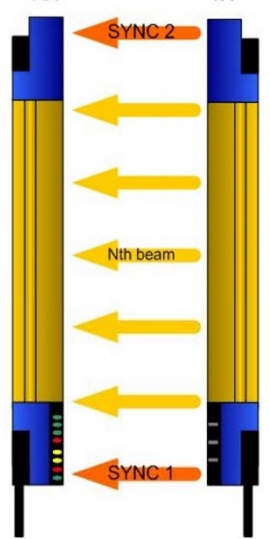

	Indication	RX Led configuration	Alignment Status	OSSD Status in Normal Operation
	No Sync, check SYNC1		NONE	OFF
	SYNC1 aligned		NONE	OFF
	SYNC2 aligned		NONE	OFF
	One or more intermediate beams not aligned		NONE	OFF
	All beams aligned		BAD	ON
	All beams aligned			ON
	All beams aligned			ON
	All beams aligned			EXCELLENT

Fig 36 - Alignment status

6 FUNCTIONS SETTING

ESPE operation functions and parameters configuration can be performed by means of push-buttons; this setting lets the user select among basic functions / basic parameters with the help of push buttons and led user interface (available on both RX and TX unit)

Basic configuration mode:

A user interface of 8 leds and 3 protected push buttons lets the user operate basic configuration. Leds are the same used for user interface in normal operation.

The user must use the provided special tool (see cfr. **INCLUDED ACCESSORIES page 62**) to activate push buttons thus accidental access to safety configuration is avoided.



Fig 37 - User interface

Basic configuration steps:

In the right side of user control panel (on both units of the light curtain) a setting interface composed by 3 push buttons is present; the purpose of the interface is to let the user set light curtain locally.

Setting interface is composed by a CONFIRM push button used to enter in BCM and to confirm the selected configuration, a SELECT push button used to roll by different functions and an ENABLE push button to activate/deactivate the current function.

Here below the necessary steps for BCM configuration:

Keep CONFIRM button pressed to enter Basic Configuration Mode

A Test Pattern is shown on led interface; **carefully check that ALL LED are lit in sequence from 2 to 8**, then current configuration is shown

Choose function to set by SELECT button; selected led blinks

Configure selected function with ENABLE button (switch led on/off)

Repeat steps 3 and 4 until desired configuration is visualized

Keep CONFIRM button pressed to authorize the new configuration

6.1 RESET TO FACTORY CONFIGURATION

User can also reset ESPE at factory configuration settings with the following push button action:

- Press and keep pressed CONFIRM button for at least 9 sec. (but less than 30 sec. otherwise the light curtain goes in lockout failure)
- The leds blink for a while, then the light curtain resets
- After reset the light curtains begins its normal functioning with the factory configuration.

6.2 FUNCTION LIST

The functions that can be chosen in SG2 MUTING are listed in the following tables.



The default configuration is indicated in bold characters

Function	LED#	Setting	Led Status				
			PWR	OSSD	EDM	ACM	LEVEL
Partial muting	2	See "Partial Muting Selection" table below					
	3						
EDM	4	Enabled				●	
		Disabled				●	
Restart mode	5	Auto					●
		Manual				●	
Muting Direction	6	T (bidirectional)					●
		L (monodirectional)				●	
Muting Timeout	7	10 min					●
		Inf.				●	
Override Trigger	8	Level					●
		Edge				●	

Fig 38 - RX Function list

Muting zone	LED #	LED Status					ESPE Zones
		PWR	OSSD	EDM	ACM	LEVEL	
A	LED 2 OFF LED 3 OFF	●	●	●			
A+B	LED 2 ON Green LED 3 OFF	●	●	●			
A+B+C	LED 2 ON Red LED 3 OFF	●	●	●			
A+B+C+D	LED 2 OFF LED 3 ON Yellow	●	●	●	●		
B	LED 2 ON Green LED 3 ON Yellow	●	●	●	●		
C	LED 2 ON Red LED 3 ON Yellow	●	●	●	●		

Fig 39 - Partial Muting selection

Function	LED#	Setting	LED Status				
			PWR	TST	SR	LR	CODE
Range Selection	3	Long				●	
		Short				●	

Fig 40 - TX Function list

7 FUNCTIONS

This chapter deals with all the functions of the light curtain.

7.1 RESTART MODE

An opaque object detected by the beams causes the switching of the OSSD outputs (i.e. the opening of the safety contacts - SAFE condition).

The restart mode allows the user to define how the light curtain returns in a Normal Operation condition.

The restart of the ESPE (i.e. the closing of the OSSD safety contacts - SAFE condition) can be carried-out in two different ways: Automatic or Manual Restart.

Automatic Restart: when an opaque object is detected, the ESPE enters in the SAFE condition. Then, after the object has been removed from the controlled area, the ESPE begins its normal functioning again.

The response time is the time between the object introduction in the protected area and the OSSDs achieving the OFF state (SAFE); the recovery time is the time within OSSDs go in the ON state (SAFE) after the object is removed.

These times are function of length. Please refer to the tables in chapter 12 for further details.

Tutti questi tempi sono funzioni di lunghezza. Fare riferimento alle tabelle contenute nel cap. **AVAILABLE MODELS AND RESPONSE TIMES** page 60 per ulteriori dettagli.

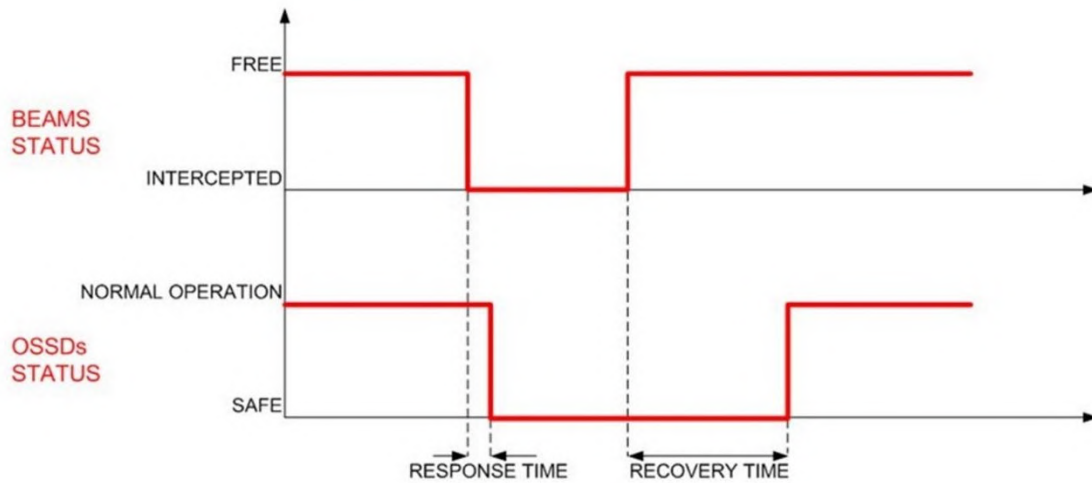

Fig 41 - Restart timings (auto)

In Automatic Restart the RESET/RESTART/ALIGN input (pin 3 of M12-12 poles – RX side) has to be left floating.

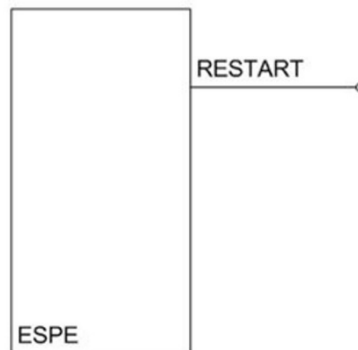

Fig 42 - Restart connection (auto)

Manual Restart: after the ESPE has detected an opaque object in the controlled area, the light curtain begins its normal functioning only by pressing the Restart button (normal open push button) and after the object has been removed from the controlled area.

The OSSDs go in normal operation state after the RESTART signal goes low, and not after 500msec. A timeout greater than 5s on the high RESTART brings the ESPE in failure lockout.

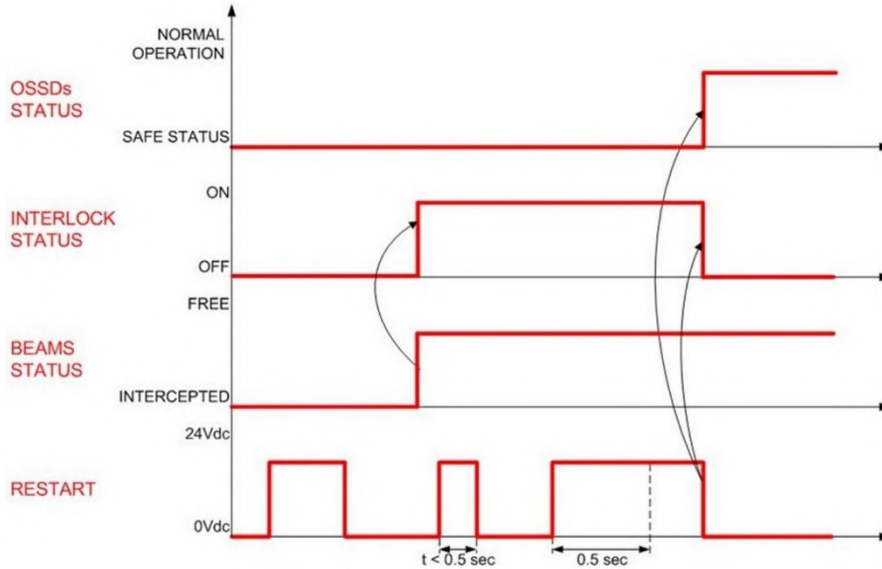

Fig 43 - Restart timings (manual)

In Manual Restart the RESET/RESTART/ALIGN input (pin 3 of M12-12 poles – RX side) has to be connected to a 24VDC normally-open contact.

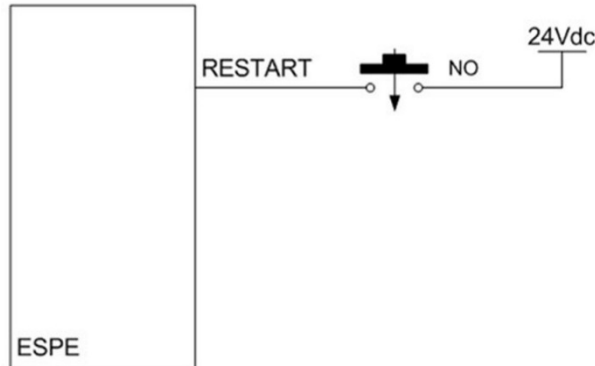

Fig 44 - Restart connection (manual)



Carefully assess risk conditions and reset modes. In applications protecting access to dangerous areas, the automatic reset mode is potentially unsafe if it allows the operator to pass completely beyond the sensitive area. In this case, the manual reset or, for example, the manual reset of the SE-SR2 relay (see cfr.ACCESSORIES page 64) is necessary.

Here below the way to select the restart mode is explained, both through push-button and the graphic user interface.

		PWR	OSSD	EDM	ACM	LEVEL
Auto	LED 5 ON Red	●	●	●	●	●
Manual	LED 5 OFF	●	●	●	●	●

Fig 45 - Restart Mode

7.2 TEST

The TEST function can be activated by pressing the 24VDC normally-open push-button connected to TX unit TEST input (pin 2 of M12-5 poles) for at least 0.5 seconds.

The TEST disables the emission stage, so the RX side sees interrupted all beams and the OSSD goes low within response time.

As shown in the timing diagram below, the OSSDs go OFF (BREAK status) after 500msec (plus a cycle time) and after the response time of the light curtain.

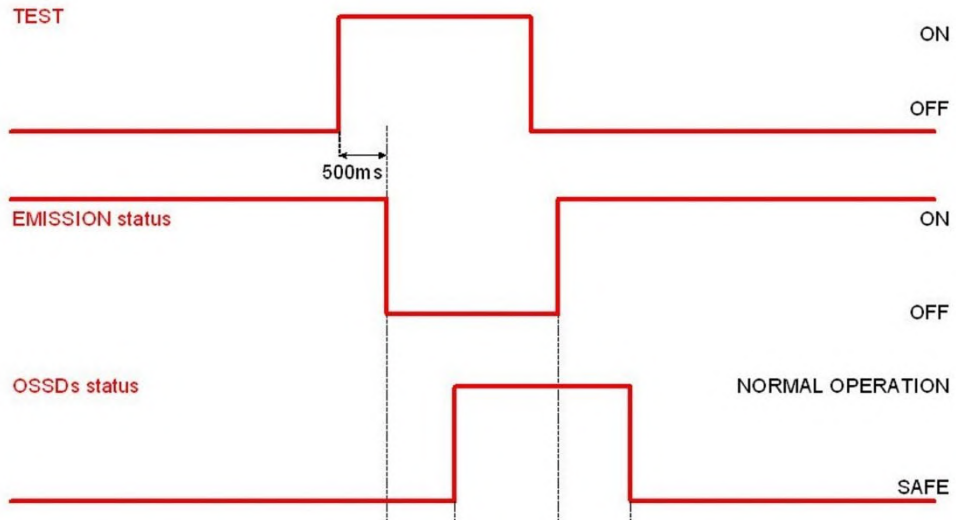

Fig 46 - Test timings

7.3 RESET

When ESPE locks into failure state user can go back to Normal Operation with a power cycle or using the activation of RESET function (non critical failures only).

To activate RESET function the 24VDC normally-open button connected to RESET/RESTART/ALIGN input (pin 3 of M12-12 poles – RX side) has to be kept pressed for at least 5 seconds in non critical failure state.

For all critical failures a power cycle is necessary.

When in failure state the light curtain can be reset with the procedure explained above except the case of failure on microprocessor, for which a power cycle is necessary.

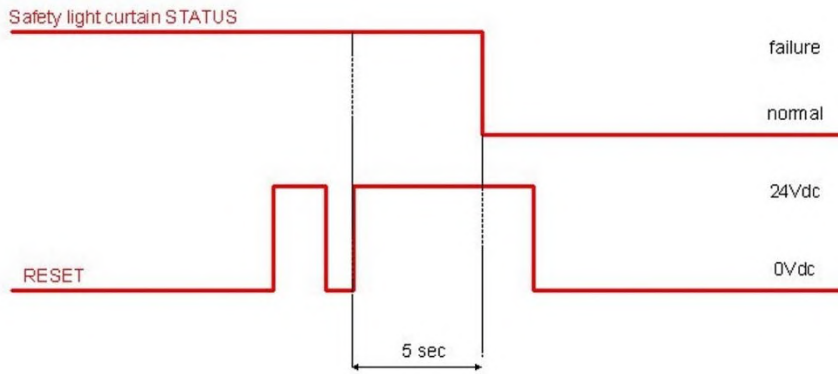

Fig 47 - Reset timings

If the error is not removed, the light curtain goes in lockout failure again.

7.4 EDM

The External Device Monitoring (EDM) function controls external devices by verifying the OSSDs status.

EDM enabled:

When EDM is enabled in PNP configuration it's necessary to connect EDM input (pin 6 of M12-12 poles - RX) to a 24 VDC normally-closed contact of the device to be monitored.



In normal operation the third led switched on in the user interface indicates that this function is active.

The figure below shows how to connect the EDM input.

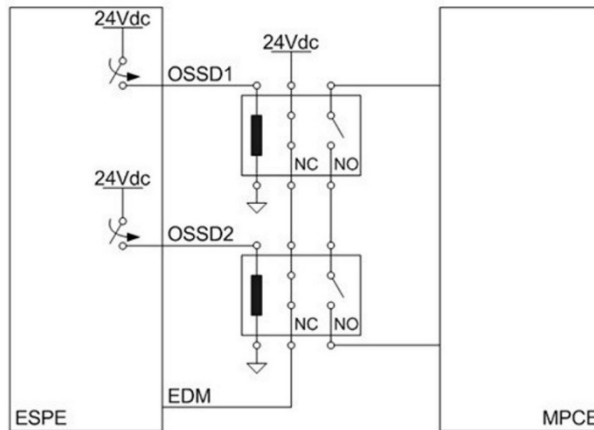

Fig 48 - PNP configuration

The function controls the 24VDC normally-closed contact switching according to the changes of the OSSDs' status.

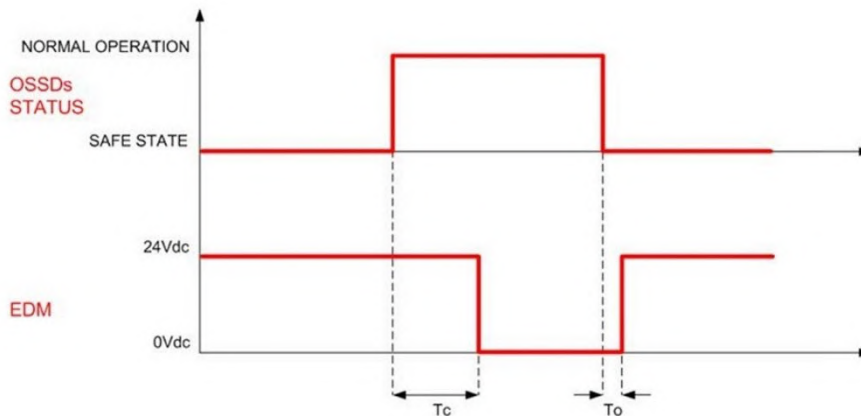

Fig 49 - EDM timings (PNP configuration)

The EDM status is antivalent with OSSDs': the timing diagram explains the relationship between the cause (OSSDs) and the effect (EDM) with the maximum permissible delay.

$T_c \leq 350$ msec (time between OSSD OFF-ON transition and EDM test)

$T_o \geq 100$ msec (time between OSSD ON-OFF transition and EDM test)

(two different times for the mechanical contact driven by a spring)

EDM disabled:

When EDM is disabled it's necessary to leave the EDM input floating.

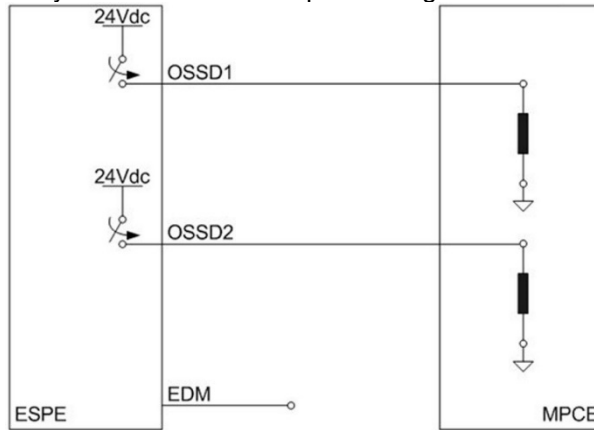

Fig 50 - EDM connection (PNP configuration)

7.5 EDM SELECTION

This function lets the user to select or exclude the monitoring of the external switching devices.

		PMR	OSSD	EDM	ACM	LEVEL
Enabled	LED 4 ON Yellow	<input checked="" type="radio"/>	<input type="radio"/>	<input type="radio"/>	<input checked="" type="radio"/>	<input type="checkbox"/>
Disabled	LED 4 OFF	<input checked="" type="radio"/>	<input type="radio"/>	<input type="radio"/>	<input checked="" type="radio"/>	<input type="checkbox"/>

Fig 51 - EDM Selection

To increase safety level, when EDM is set OFF, at start-up ESPE checks if EDM input is floating.

7.6 REDUCTION RANGE

This function allows the user to select the maximum operating distance at which the curtains can be mounted. If TX is configured as Long Range the maximum operating distance is 20m; if TX is configured as Short Range the maximum operating distance is 12m.

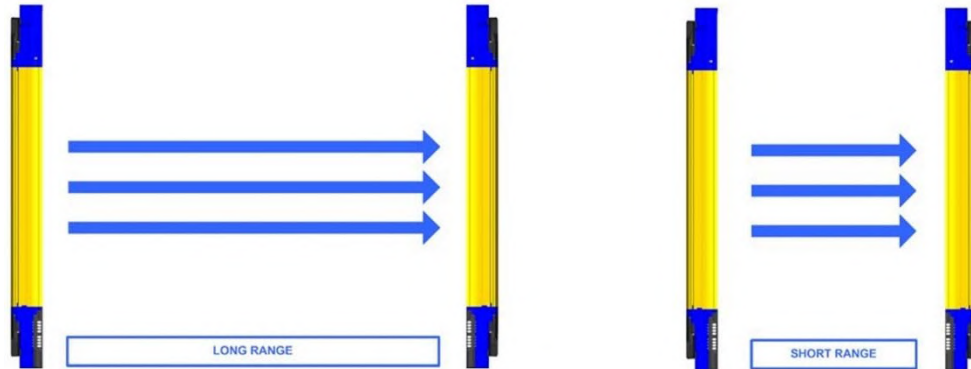

Fig 52 - Reduction range

		PWR	TST	SR	LR	— CODE —				
Long	LED 3 ON Yellow	<input checked="" type="checkbox"/>	<input type="checkbox"/>	<input checked="" type="checkbox"/>	<input type="checkbox"/>	<input type="checkbox"/>	<input type="checkbox"/>	<input type="checkbox"/>	<input type="checkbox"/>	<input type="checkbox"/>
Short	LED 3 OFF	<input checked="" type="checkbox"/>	<input type="checkbox"/>	<input checked="" type="checkbox"/>	<input type="checkbox"/>	<input type="checkbox"/>	<input type="checkbox"/>	<input type="checkbox"/>	<input type="checkbox"/>	<input type="checkbox"/>

Fig 53 - Reduction Range

In particular, if long range is selected TX and RX can be mounted at the maximum allowed operating distance; short range is indicated in those cases in which multiple couples of light curtains have to be mounted near and no code can be used.

7.7 MUTING

Muting function allows automatic deactivation of the safety function on the whole or part of protected height in order to carry out definite cyclical operations without blocking machine work.

As the pertaining safety requirements demand, ESPE is equipped with two Muting activation inputs, MUTING1 and MUTING2.

The Muting sensors must be able to recognise the passing material (pallets, vehicles, ...) according to material's length and speed.

In case of different transport speeds in the Muting area, it is necessary to consider their effect on the total Muting duration.

- The Muting function excludes the light curtain during functioning, maintaining active the OSSDs' outputs, according to particular operating requirements (see figures below).

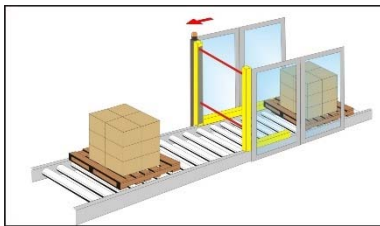

Fig 54 - L-shaped version with integrated Muting sensors for unidirectional Muting

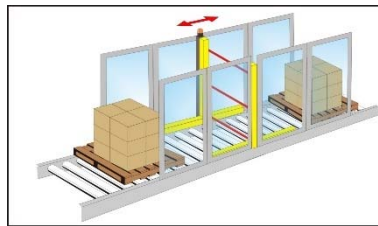

Fig 55 - T-shaped version with integrated Muting sensors for bidirectional Muting

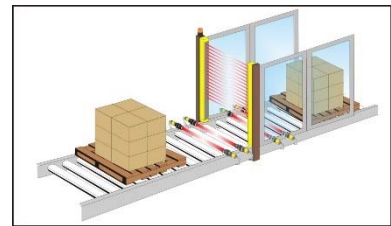

Fig 56 - Linear version with external Muting sensors

- The safety light curtain is equipped with two inputs (MUTING1 and MUTING2) for the activation of this function, according to the current Standards.
- This function is particularly suitable when an object, but not a person, has to pass through the dangerous area, under certain conditions.
- It is important to remember that the Muting function represents a forced condition of the system and therefore has to be used with the necessary precautions.
- If MUTING1 and MUTING2 inputs are activated by two Muting sensors or actuators, these should be correctly connected and positioned in order to avoid undesired Muting or potentially dangerous conditions for the operator.
- MUTING1 and MUTING2 can't be activated simultaneously.
- State of Muting is signalled by an external Muting Lamp (that can be connected to the light curtains with the pin 10 of the M12-12 poles connector) and by some leds on the user interface. When the Muting function is ON the LAMP and the leds begin to blink.
- During the installation take care to place the lamp in a position as visible as possible.
- If the external lamp is broken and/or not connected, the Muting request causes a SAFE lockout condition and the corresponding failure is signalled.
- If both first and last beams are intercepted by the passing material the light curtain recovery time may be longer. A material moving faster than 1 m/s could lead light curtain to switch in OFF-state at the end of Muting sequence.



Select carefully the configuration, as a wrong configuration can cause the incorrect functioning of the Muting function and a reduction of the safety level. For correct use of Muting, Please refer to the relevant reference standards.
The Muting sensors must be positioned in such a way that the activation of the Muting function is not possible with the accidental passing of a person.
Particular attention must be paid to the use of the one-way L-Muting mode: the external Muting sensors or the SG-L-ARMS Muting arms must be positioned so as to allow the passage of the material coming out of the dangerous area protected by the light curtain.

7.7.1 Muting function disable

During light curtain operations Muting function can be dynamically disabled or enabled: when disabled no valid Muting request will be accepted at the MUTINGX inputs and safety function will always be on.

The user can disable the Muting function at runtime by setting a high level on the signal MUTING DISABLE (pin 7 of the M12-12 poles connector).

7.7.2 Muting signalling devices

In order to make use of Muting function, it is compulsory to connect a dedicated signalling device (lamp); without it the light curtain goes in failure lock-out state.

Both incandescent and LED lamps are allowed. In case of use of LED lamp, take care to connect it respecting the right polarity .

A Lamp TEST is executed cyclically when the lamp is lighted on in order to guarantee the detection of lack of functionality.

If a lamp break is detected, ESPE goes in Lamp Failure Lock-Out state and shows the related message on the display (refer to cfr. **TECHNICAL DATA** page 59 for informations about the lamp).

7.7.3 Typical Muting application and safety light curtain connection

The figure shows a typical Muting application: a protection installed on a conveyor should allow the pack passing-by but not the worker.

The ESPE temporarily suspends its safety function on a correct activation sequence of A1, B1, A2, B2 sensors.

These sensors can be optical, mechanical, proximity sensors ... etc., with high output PNP when the object is detected.

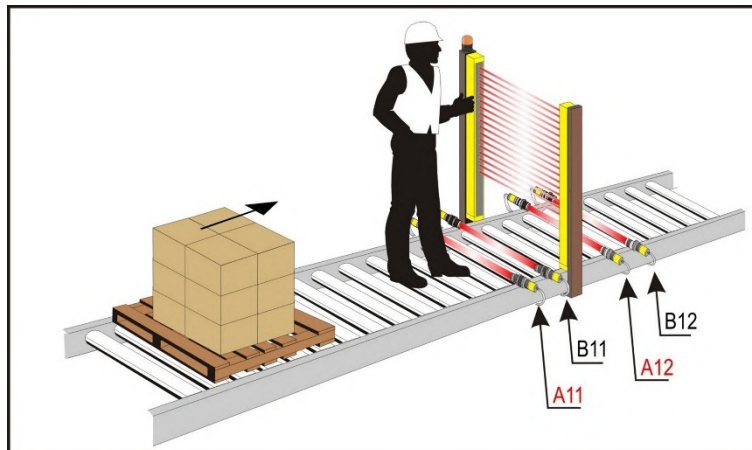

Fig 57 - Typical Muting Application

7.7.4 Muting direction

The ESPE can be used with both bidirectional (T type, four sensors) and monodirectional (L type, two sensors) Muting.

Bidirectional Muting can be used in those applications in which the packs can move in both directions and monodirectional Muting can be used in those applications in which the packs move in one direction only.

In BCM the maximum activation delay between MUTING1 and MUTING2 (T12max) is 4 sec.

Muting T

In T type operations the device enters Muting function if the input MUTING2 goes high within a fixed T12max of 4s after the rise of MUTING1 (or vice versa).

The Muting function ends as soon as the signal on MUTING1 or MUTING2 goes low.

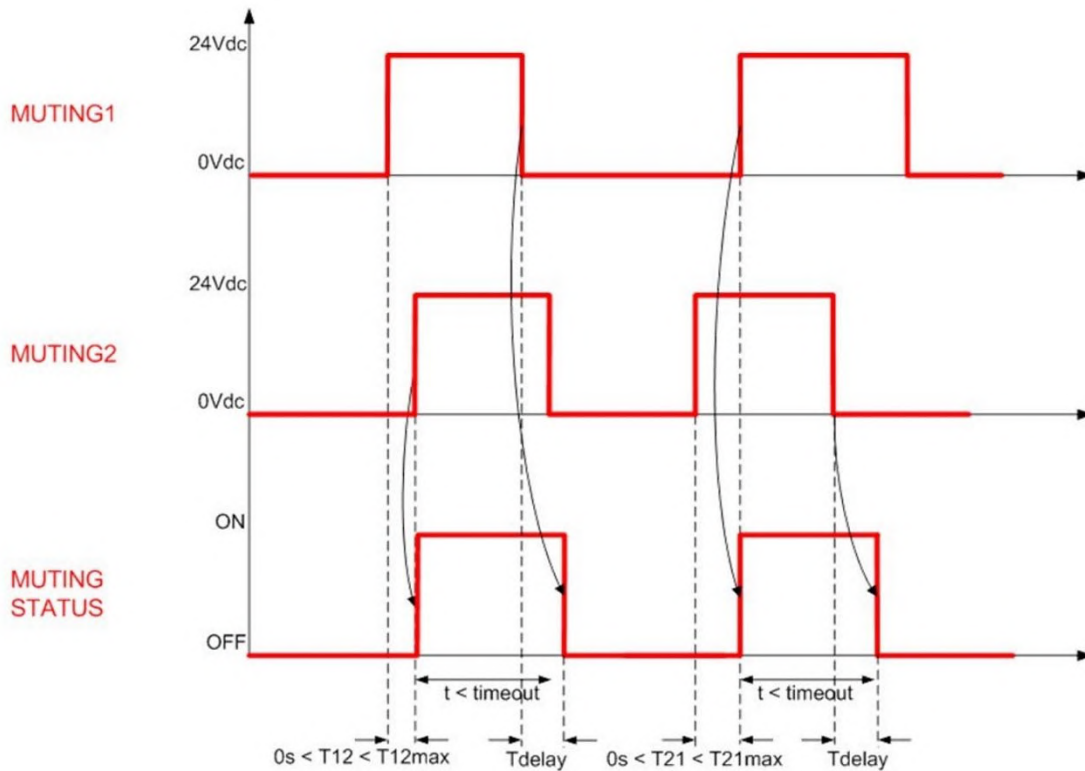

Fig 58 - T Muting timings

The sensors named A1/A2 are connected to the same Muting input (MUTING1) and the sensors named B1/B2 are connected to MUTING2.

The sensors that end with "1" are on the same side of the light curtain and are on the opposite side of the sensors that end with "2".

"D" is the distance at which the sensors A1/A2 or B1/B2 have to be mounted; it depends on the package length (L):

$$D < L$$

"d1" is the maximum distance between the Muting sensors; it depends on the package speed (V):

$$d1_{max}[cm] = V[m/s] * T12[s] * 100,$$

"d2" is the maximum distance for the Muting request to be accepted; it depends on the package speed (V):

$$d2_{max}[cm] = V[m/s] * T12[s] * 100,$$

where "T12" is the activation delay between MUTING1 and MUTING2, i.e. 4s.

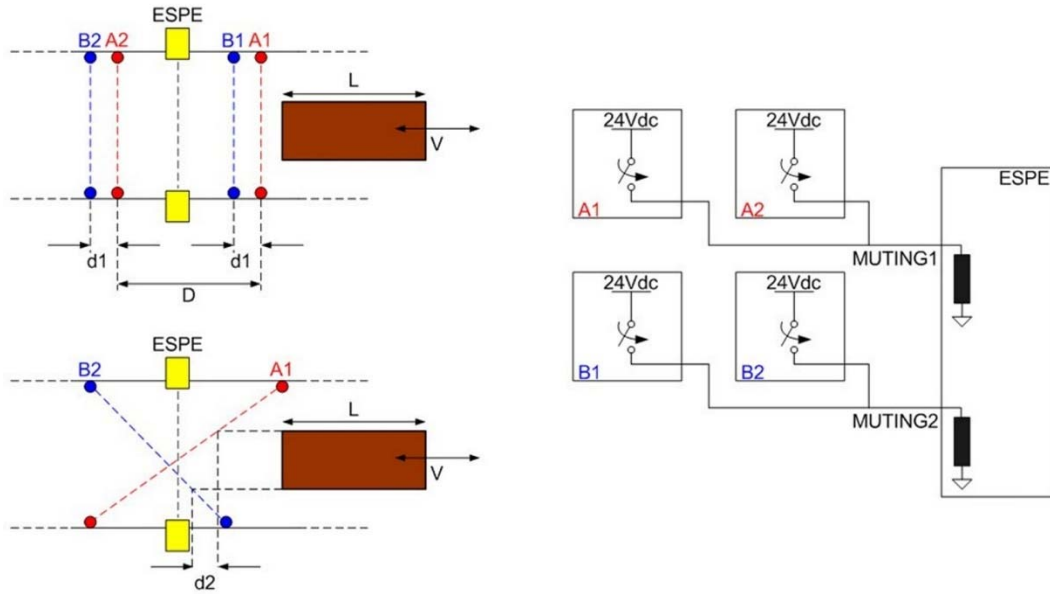

Fig 59 - Muting T connection

Muting L

In L type operation the device enters Muting function if the inputs go high in a particular order: MUTING1 has to activate first, then MUTING2 can activate; if MUTING2 activates before MUTING1, the device doesn't enter the Muting function.

"T12" is the activation delay between MUTING1 and MUTING2 and is a fixed time of 4s.

The Muting function ends after a time that is a multiple of the activation delay between the two sensors (this time is $m * T12$).

The value of "m" (T12 multiplier) for these light curtains cannot be changed and is equal to 2.



Muting L must be used exclusively for removing materials from the dangerous area.

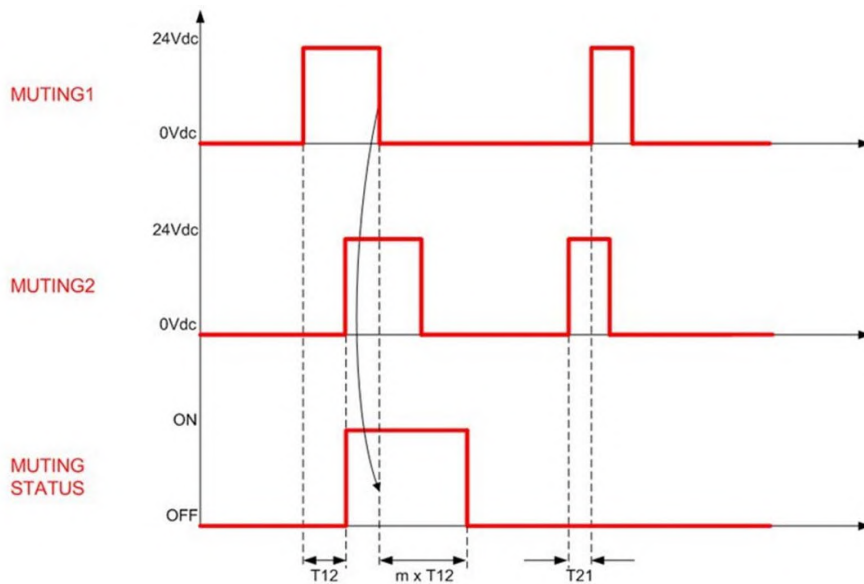

Fig 60 - Muting L timings

The sensor named A is the farthest from the light curtain, so its beam is intercepted first. Making reference to the next figure, since the pack goes from right to left only, B sensor can't be intercepted first; if this happens the device doesn't enter Muting function.

"V" indicates a constant speed. As a consequence, "d1" is fixed according to the following formula:

$$d1[cm] = V[m/s] * T12[s] * 100$$

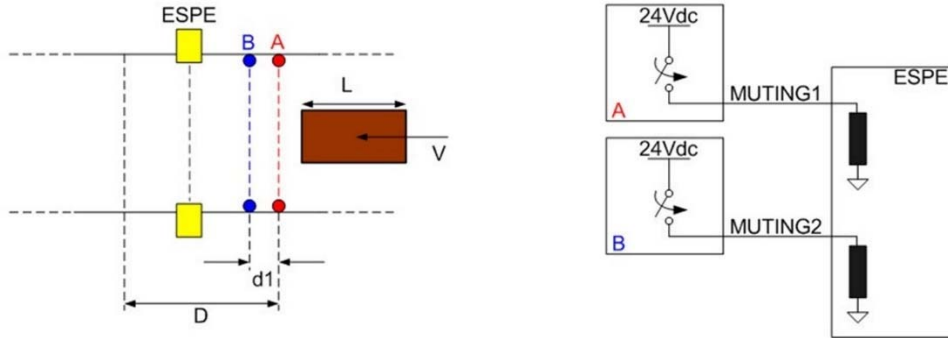

Fig 61 - Muting L connection

		PMR	OSSD	EDM	ACM	LEVEL
T (bidirectional)	LED 6 ON Green	●	●	●	●	●
L (monodirectional)	LED 6 OFF	●	●	●	●	●

Fig 62 - Muting Direction

7.7.5 Muting timeout

Muting timeout is a time that defines the maximum duration of Muting function; after the timeout the Muting ends. The user can select a timeout of 10 minutes or infinite; “infinite” means that muting timeout could never end: if the conditions of muting persist, the muting function still continues to exist.

This is not compliant with the EN 61496-1: 2013 rule and the user is warned about it.

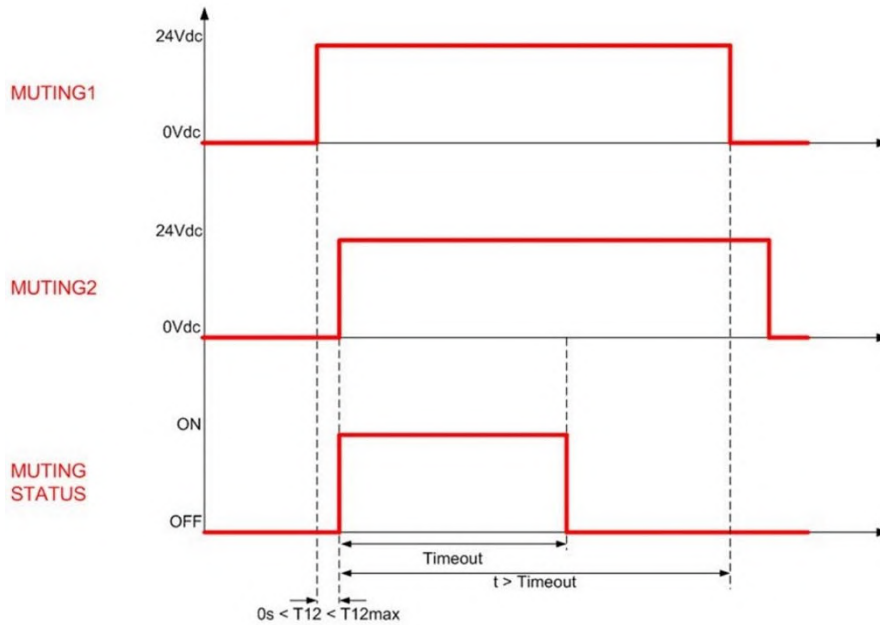

Fig 63 - Muting timeout

		PWR	OSSD	EDM	ACM	LEVEL
10 min	LED 7 ON Green	●	●	●	●	●
infinite	LED 7 OFF	●	●	●	●	●

Fig 64 - Muting timeout



Infinite is not EN 61496-1: 2013 compliant!

7.7.6 Partial Muting

It's possible to configure the type of muting: total or partial.

Partial muting can be useful in those applications in which the user wants to limit the muting function effects to selected zones only.

Hereafter the table that resumes the configuration in case of partial muting is presented.

Muting zone	LED #	LED Status							ESPE Zones
		PWR	OSSD	EDM	ACM	LEVEL			
A	LED 2 OFF LED 3 OFF	●	●	●	●	●	●	●	
A+B	LED 2 ON Green LED 3 OFF	●	●	●	●	●	●	●	
A+B+C	LED 2 ON Red LED 3 OFF	●	●	●	●	●	●	●	
A+B+C+D	LED 2 OFF LED 3 ON Yellow	●	●	●	●	●	●	●	
B	LED 2 ON Green LED 3 ON Yellow	●	●	●	●	●	●	●	
C	LED 2 ON Red LED 3 ON Yellow	●	●	●	●	●	●	●	

Fig 65 - Partial Muting Selection

7.8 OVERRIDE

Override function allows the user to force safety function deactivation whenever it's necessary to restart the machine despite one or more ESPE beams are intercepted.

The aim is clearing protected area of any working materials blocked ahead of ESPE because of (i.e.) a cycle anomaly.

Override redundant inputs have to be connected to a 24VDC normally-open contact and to a GND normally-open contact.

As the pertaining requirements request ESPE is equipped with two Override activation inputs: OVERRIDE1 and OVERRIDE2 (respectively, pin 4 of the M12-12 poles connector and pin 9 of the M12-12 poles connector – RX).

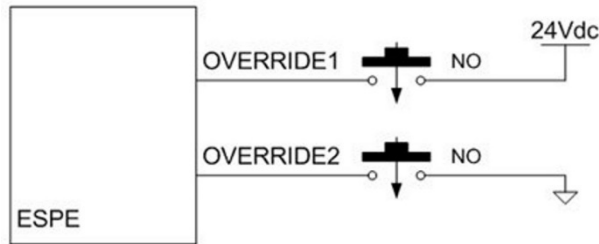

Fig 66 - Override connection

Necessary condition for override request to be accepted is: ESPE in SAFE state and at least one Muting sensor intercepted.

When such condition is verified user interface visualizes “override attention status” with both red OSSD led and alignment leds blinking.

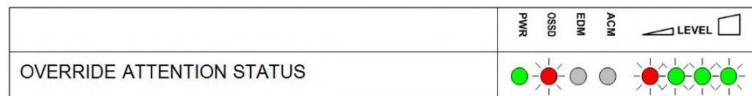

Fig 67 - Override attention status

Then, an override request is accepted only if signals at OVERRIDE X inputs follow the timings shown hereafter.

Override function will automatically end when one of the following conditions is present:

- all the Muting sensors are deactivated (in a T-Muting configuration)
- all the Muting sensors are deactivated AND no beams are intercepted (in a L-Muting configuration)
- the pre-determined time limit has expired
- the requirements for actuation aren't met anymore (for example, one override input is deactivated)

7.8.1 Override mode

It's possible to configure the trigger of override inputs: Level or Edge.

As explained in diagrams below two types of override trigger sequence are accepted on external inputs:

LEVEL TRIGGER: Override engaged until both contacts are closed AND at least one Muting sensor is intercepted.

OVERRIDE STATUS: status is an output signal that informs the user if the override inputs are active with override conditions present.

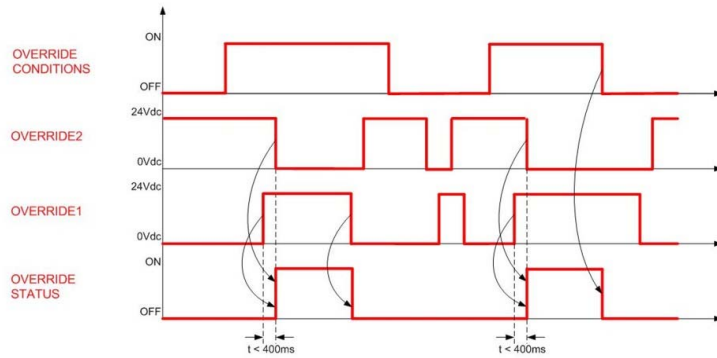

Fig 68 - Override timings (level trigger)

EDGE TRIGGER: override engaged on contacts closing until at least one Muting sensor is intercepted. In this case the override state rests even if the override contacts are released.

The device exits the override state when one of the following events happens:

- the Muting sensors are deactivated (T-Muting) or the Muting sensor are deactivated AND no beams are intercepted (L-Muting)
- the timeout expires

OVERRIDE STATUS: is an output signal that informs the user if the override inputs are active with override conditions present.

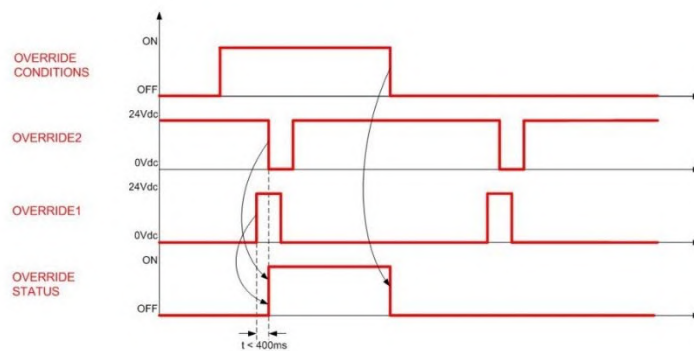

Fig 69 - Override timings (edge trigger)

		PMR	OSSD	EDM	ACM	LEVEL
Level	LED 8 ON Green	●	●	●	●	▲
Edge	LED 8 OFF	●	●	●	●	■

Fig 70 - Override Mode

7.8.2 Override timeout

Override status timeout is 120s: if Override conditions remain active and both Override contacts remain closed (this condition only in Level Trigger Mode) more than 120s, the Override goes low in any case after a maximum of 120s.

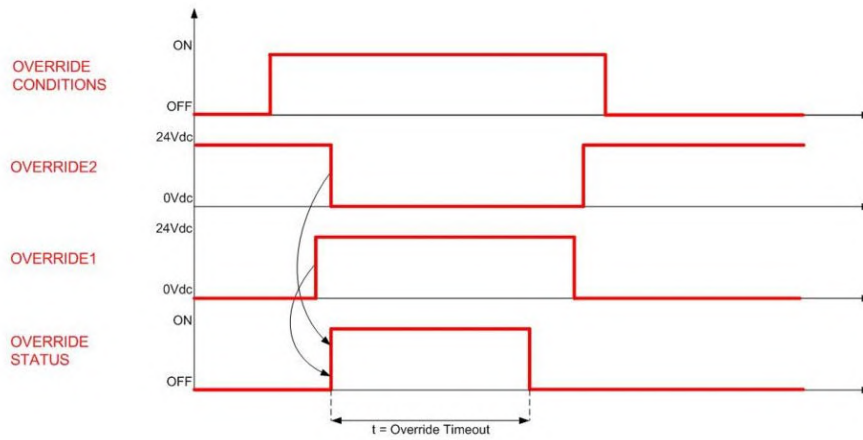

Fig 71 - Override timeout timings

8 USER INTERFACE AND DIAGNOSTICS

8.1 USER INTERFACE

In the left side of user control panel (on both units of light curtains) an 8 LEDs user interface helps customer to control and check the state of the light curtain, for alignment mode, normal operation and for troubleshooting activity.

User interface allows the user to understand which is the configuration set with the push buttons.



ESPE WORKING MODE	INDICATION	LED CONFIGURATION ● Off ● On ● Blink ● Indifferent	SUGGESTED ACTION
ALIGNMENT	NOT ALIGNED	● Power ● OSSDs (Blink) ● EDM ● ACM ● Sync ● LEVEL (Red) ● Fault Code (Red)	
	1 ST SYNC ENGAGED	● Power ● OSSDs (Blink) ● EDM ● ACM ● Sync ● LEVEL (Red) ● Fault Code (Red)	
	LAST SYNC ENGAGED	● Power ● OSSDs (Blink) ● EDM ● ACM ● Sync ● LEVEL (Red) ● Fault Code (Red)	
	MINIMUM SIGNAL LEVEL	● Power ● OSSDs (Blink) ● EDM ● ACM ● Sync ● LEVEL (Red) ● Fault Code (Red)	
	MAXIMUM SIGNAL LEVEL	● Power ● OSSDs (Blink) ● EDM ● ACM ● Sync ● LEVEL (Red, Green, Green, Green) ● Fault Code (Red)	
NORMAL OPERATION MANUAL RESTART ONLY	INTERLOCK FREE BEAMS	● Power ● OSSDs (Red) ● EDM (Grey) ● ACM (Grey) ● Sync ● LEVEL (Red, Green, Grey, Grey) ● Fault Code (Red)	user can restart device in normal operation activating RESTART line
	INTERLOCK INTERRUPTED BEAMS	● Power ● OSSDs (Red) ● EDM (Grey) ● ACM (Grey) ● Sync ● LEVEL (Red, Green, Green, Green) ● Fault Code (Red)	user must free protected area before activating RESTART line
NORMAL OPERATION	OSSD ON (MAXIMUM ALIGNMENT)	● Power ● OSSDs (Green, Green) ● EDM (Grey) ● ACM (Grey) ● Sync ● LEVEL (Red, Green, Green, Green) ● Fault Code (Red)	
	LEVEL SIGNAL ON BEAMS	● Power ● OSSDs (Red) ● EDM (None) ● ACM (None) ● Sync ● LEVEL (Red, Green, Green, Green) ● Fault Code (Red) ● Power ● OSSDs (Green) ● EDM (Insufficient) ● ACM (None) ● Sync ● LEVEL (Red, Green, Green, Green) ● Fault Code (Red) ● Power ● OSSDs (Green) ● EDM (Low) ● ACM (None) ● Sync ● LEVEL (Red, Green, Green, Green) ● Fault Code (Red) ● Power ● OSSDs (Green) ● EDM (Good) ● ACM (None) ● Sync ● LEVEL (Red, Green, Green, Green) ● Fault Code (Red) ● Power ● OSSDs (Green) ● EDM (Best) ● ACM (None) ● Sync ● LEVEL (Red, Green, Green, Green) ● Fault Code (Red)	
	EDM ACTIVE	● Power ● OSSDs (Grey) ● EDM (Yellow) ● ACM (Grey) ● Sync ● LEVEL (Grey, Grey, Grey, Grey) ● Fault Code (Grey)	

Fig 72 - User interface (RX)

ESPE WORKING MODE	INDICATION	LED CONFIGURATION		SUGGESTED ACTION
		● Off ● On ● Blink ● Indifferent		
NORMAL OPERATION (MUTING)	MUTING ACTIVE	● ● ● ●	● ● ● ●	if unexpected OSSD OFF with muting active, check partial muting configuration
	OVERRIDE ACTIVE	● ● ● ●	● ● ● ●	
	OVERRIDE ATTENTION STATUS	● ● ● ●	● ● ● ●	trigger override button to force OSSDs ON
	OVERRIDE TIMINGS FAILURE	● ● ● ●	● ● ● ●	check and repeat override activation sequence check override connections
	LAMP FAILURE	● ● ● ●	● ● ● ●	check if lamp connections and/or if lamp is broken
FAILURE INFORMATION	FAILURE ON OSSDS	● ● ● ●	● ● ● ●	Activate RESET line. If error persists contact Technical Support
	FAILURE ON MICROPROCESSOR	● ● ● ●	● ● ● ●	Activate RESET line. If error persists contact Technical Support
	FAILURE ON OPTICS	● ● ● ●	● ● ● ●	Activate RESET line. If error persists contact Technical Support
	FAILURE ON EDM	● ● ● ●	● ● ● ●	Check EDM feedback line and EDM configuration. Activate RESET line
	FAILURE ON RESTART	● ● ● ●	● ● ● ●	Check RESTART line connection. Activate RESET line
	COMUNICATION FAILURE	● ● ● ●	● ● ● ●	Check the correct mounting of terminator cap. Activate RESET line
	BCM CONFIGURATION FAILURE	● ● ● ●	● ● ● ●	Re-operate Basic Configuration. If error persists contact Technical Support
	CRITICAL FAILURE	● ● ● ●	● ● ● ●	Turn ON/OFF ESPE. If error persists contact Technical Support
	POWER SUPPLY FAILURE	● ● ● ●	● ● ● ●	Check Power Supply Connection. If error persists contact Technical Support

Fig 73 - User interface (RX)



A critical failure can't be re-established with a Reset procedure but it's necessary to switch-off and switch-on the light curtain; if the failure persists, please contact the DATASENSING Technical Support.

TX SIDE:



ESPE WORKING MODE	INDICATION	LED CONFIGURATION								SUGGESTED ACTION
		Off	On	Blink	Indifferent	Off	On	Blink	Indifferent	
NORMAL OPERATION	SHORT RANGE EMISSION									
	LONG RANGE EMISSION									
	TEST									if undesired Test, check TEST line connection
	EMISSION									
FAILURE	FAILURE ON MICROPROCESSOR									Activate RESET line. If error persists contact Technical Support
	FAILURE ON OPTICS									Activate RESET line. If error persists contact Technical Support
	BCM CONFIGURATION FAILURE									Re-operate Basic Configuration. If error persists contact Technical Support
	COMUNICATION FAILURE									Check the correct mounting of terminator cap. Activate RESET line
	CRITICAL FAILURE									Turn ON/OFF ESPE. If error persists contact Technical Support

Fig 74 - User interface (TX)



A critical failure can't be re-established with a Reset procedure but it's necessary to switch-off and switch-on the light curtain; if the failure persists, please contact the DATASENSING Technical Support.

9 PERIODICAL CHECKS

The following is a list of recommended check and maintenance operations that should be periodically carried-out by qualified personnel (cfr. **Controls after first installation page 23**)

Check that:

- The ESPE stays in SAFE state during beam interruption along the entire protected area, using the specific Test Piece (TP-14 or TP-30)
- The ESPE is correctly aligned. Press slightly product side, in both directions and the red LED (named OSSD on RX side) must not turn ON.
- Enabling the TEST function (on TX side), the OSSD outputs should open (the red LED, OSSD on RX side, is ON and the controlled machine stops)
- The response time upon machine STOP (including response time of the ESPE and of the machine) is within the limits defined for the calculation of the safety distance (see chapter **INSTALLATION page 16**).
- The safety distance between the dangerous areas and the ESPE are in accordance with the instructions included in chapter **INSTALLATION page 16**.
- Access of a person between ESPE and machine dangerous parts is not possible nor it is possible for him/her to stay there
- Access to the dangerous area of the machine from any unprotected area is not possible
- The ESPE and the external electrical connections are not damaged.

The frequency of checks depends on the particular application and on the operating conditions of the safety light curtain.

9.1 GENERAL INFORMATION AND USEFUL DATA



Safety MUST be a part of our conscience.

The safety devices fulfil their safety function only if they are correctly installed, in accordance with the Standards in force.

If you are not certain to have the expertise necessary to install the device in the correct way, DATASENSING is at your disposal to carry out the installation.

The device uses fuses that are not self-resetting. Consequently, in presence of short-circuits causing the cut-off of these fuses, both safety light curtains (RX and TX) shall be sent to DATASENSING Repair Service Department.

A power failure caused by interferences may cause the temporary or trigger Safety State over connected safety Fieldbus, but the safe functioning of the light curtain will not be compromised.

9.2 WARRANTY

The warranty period for this product is 36 months.

See the General Terms and Conditions of Sales at www.datasensing.com for further details.

DATASENSING will not be liable for any damages to persons and things caused by the non-observance of the correct installation modes and device use.

In presence of a non-functioning device, always return the emitting and receiving units for repair or replacement.

10 DEVICE MAINTENANCE

DATASENSING safety light curtains do not require special maintenance operations.

To avoid the reduction of the operating distance, optic protective front surfaces must be cleaned at regular intervals. Use soft cotton cloths dampened in water.

Do not apply too much pressure on the surface in order to avoid making it opaque.

Please do not use on plastic surfaces or on light curtain painted surfaces:

- **alcohol or solvents**
- **wool or synthetic cloths**
- **paper or other abrasive materials**

10.1 PRODUCT DISPOSAL



For information about the disposal of Waste Electrical and Electronic Equipment (WEEE), please refer to the website at www.datasensing.com.

11 TECHNICAL DATA

SAFETY CATEGORY:	Type 2 (rif. EN 61496-1: 2013)
	SIL 1 (rif. EN 61508)
	SIL CL 1 (rif. EN 62061:2005/A2: 2015)
	PL c, Cat. 2 (rif. EN ISO 13849-1: 2015)
	PFHd [1/h] = 1,04E -08
	MTTFd [years] = 273

ELECTRICAL DATA	
Power supply (Vdd):	24 VDC ± 20%
Consumption (TX):	3 W max
Consumption (RX):	5 W max (without load)
Outputs:	2 PNP
Short-circuit protection:	1.4 A max
Output current:	0.5 A max su ciascuna uscita
Output voltage – status ON:	Vdd –1 V min
Output voltage – status OFF:	0.2 V max
Capacitive load:	2.2 uF @ 24Vcc max
Response times:	see chapter AVAILABLE MODELS AND RESPONSE TIMES page 60
Recovery time:	Typ. 100ms *
Controlled height:	300..1800 mm
Auxiliary functions:	test; manual/automatic restart; EDM; reset; muting;
Electrical protection:	Classe I / Classe III (see chapter ELECTRICAL CONNECTIONS page 27)
Current for External Lamp:	20 mA min; 300 mA max
Connections:	
for receiver:	M12 12-pole + M12 5-pole
for emitter:	M12 5-pole
Cables length (for power supply):	50 m. max

OPTICAL DATA	
Emitting light (λ):	Infrared, LED (950 nm)
Resolution:	30 mm
Operating distance:	0.2...20 m
Ambient light rejection:	EN 61496-2: 2013

MECHANICAL AND ENVIRONMENTAL DATA	
Operating temperature:	0...+ 50 °C
Storage temperature:	- 25...+ 70 °C
Temperature class:	T6
Humidity:	15...95 % (no condensation)
Mechanical protection:	IP 65 EN 60529
Vibrations:	Width 0.35 mm, Frequency 10 ... 55 Hz 20 sweep per axis, 1octave/min EN 60068-2-6
Shock resistance:	16 ms (10 G) 1,000 shocks per axis EN 60068-2-29
Housing material:	Painted aluminium (yellow RAL 1003)
Front side material:	PMMA
Caps material:	PBT Valox 508 (PANTONE 072C)
Cover material:	PC LEXAN
Weight:	1.35 kg per linear meter for single unit

* Recovery Time may be longer if both first and last optics are intercepted.

12 AVAILABLE MODELS

MODEL	Controlled height (mm)	No. Beams	Response time (msec)	Resolution (mm)
SG2-30-030-OO-W	300	16	13	30
SG2-30-045-OO-W	450	24	14	30
SG2-30-060-OO-W	600	32	15	30
SG2-30-075-OO-W	750	40	16	30
SG2-30-090-OO-W	900	48	17	30
SG2-30-105-OO-W	1050	56	18	30
SG2-30-120-OO-W	1200	64	19	30
SG2-30-135-OO-W	1350	72	19	30
SG2-30-150-OO-W	1500	80	20	30
SG2-30-165-OO-W	1650	88	21	30
SG2-30-180-OO-W	1800	96	22	30

Product	EN ISO 13849-1				Prob. of danger failure/hour	Life span	Mean Time to Dangerous Failure	Average Diagnostic Coverage	Safe Failure Fraction	Hardware Fault Tolerance
	PL	CAT	SIL	SIL CL						
SG2-30-030-OO-W	c	2	1	1	1,04E-08	20	273	97,50%	98,40%	0
SG2-30-045-OO-W	c	2	1	1	1,04E-08	20	273	97,50%	98,40%	0
SG2-30-060-OO-W	c	2	1	1	1,04E-08	20	273	97,50%	98,40%	0
SG2-30-075-OO-W	c	2	1	1	1,04E-08	20	273	97,50%	98,40%	0
SG2-30-090-OO-W	c	2	1	1	1,04E-08	20	273	97,50%	98,40%	0
SG2-30-105-OO-W	c	2	1	1	1,04E-08	20	273	97,50%	98,40%	0
SG2-30-120-OO-W	c	2	1	1	1,04E-08	20	273	97,50%	98,40%	0
SG2-30-135-OO-W	c	2	1	1	1,04E-08	20	273	97,50%	98,40%	0
SG2-30-150-OO-W	c	2	1	1	1,04E-08	20	273	97,50%	98,40%	0
SG2-30-165-OO-W	c	2	1	1	1,04E-08	20	273	97,50%	98,40%	0
SG2-30-180-OO-W	c	2	1	1	1,04E-08	20	273	97,50%	98,40%	0

13 OVERALL DIMENSIONS

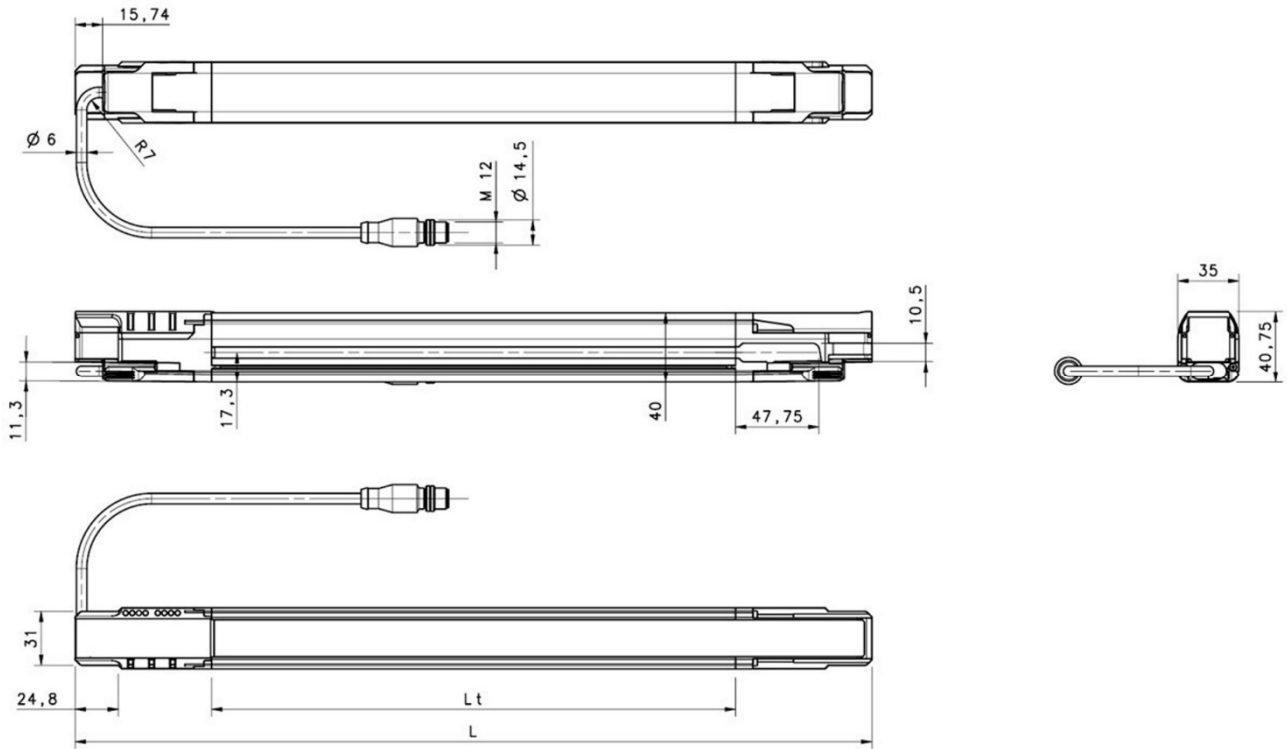

Fig 75 - Overall dimensions (mm)

MODEL	Lt (mm)	L (mm)
SG2-30-030-OO-W	150	306,3
SG2-30-045-OO-W	300	456,3
SG2-30-060-OO-W	450	606,3
SG2-30-075-OO-W	600	756,3
SG2-30-090-OO-W	750	906,3
SG2-30-105-OO-W	900	1056,3
SG2-30-120-OO-W	1050	1206,3
SG2-30-135-OO-W	1200	1356,3
SG2-30-150-OO-W	1350	1506,3
SG2-30-165-OO-W	1500	1656,3
SG2-30-180-OO-W	1650	1806,3

14 INCLUDED ACCESSORIES

Metal angled fixing bracket (ST-KSTD)

MODEL	DESCRIPTION
ST-KSTD	Angled fixing bracket (4 pcs kit)

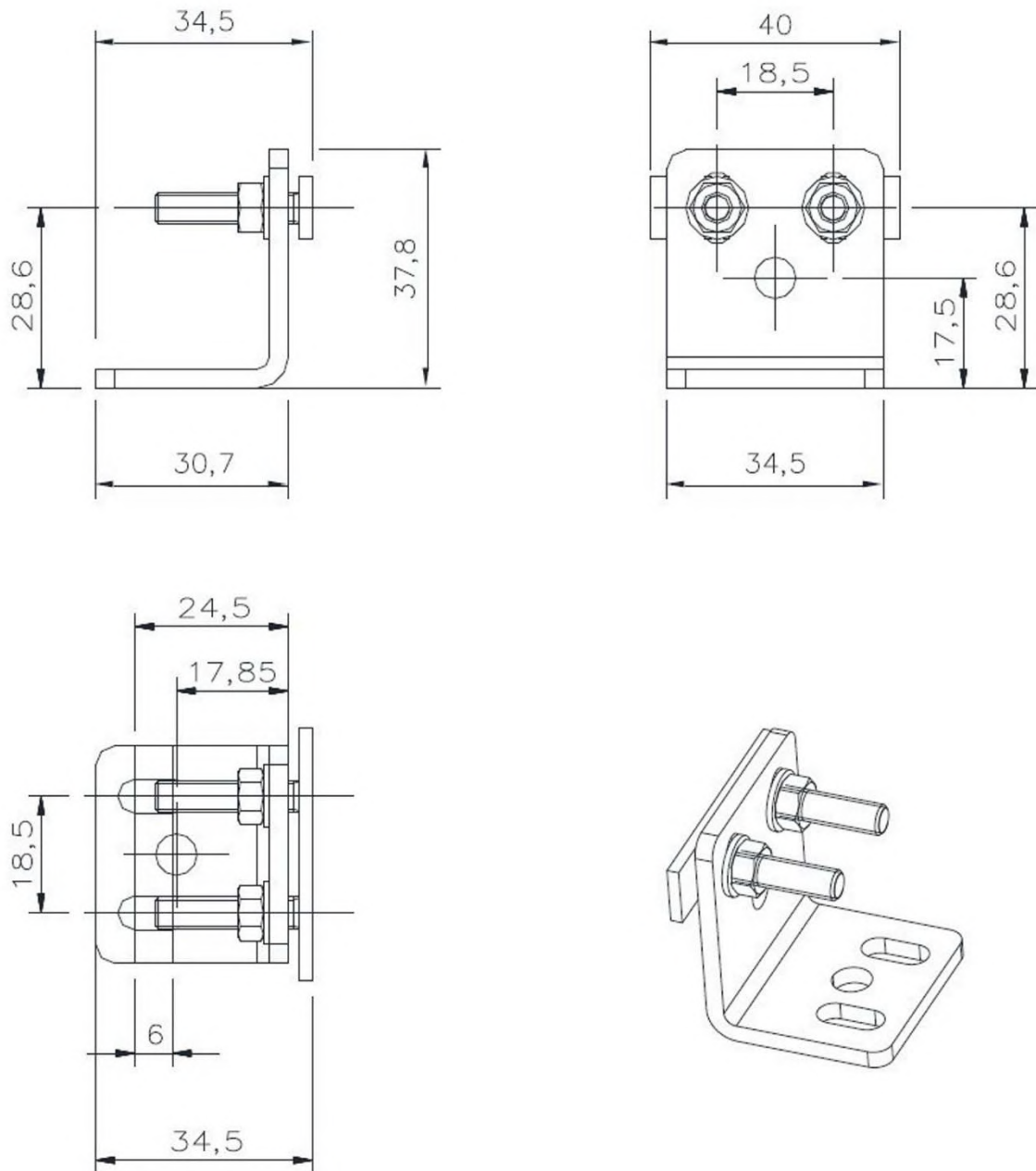

Fig 76 - Dimensions (mm)

14.1 TERMINATOR CAP (CVL-5196)

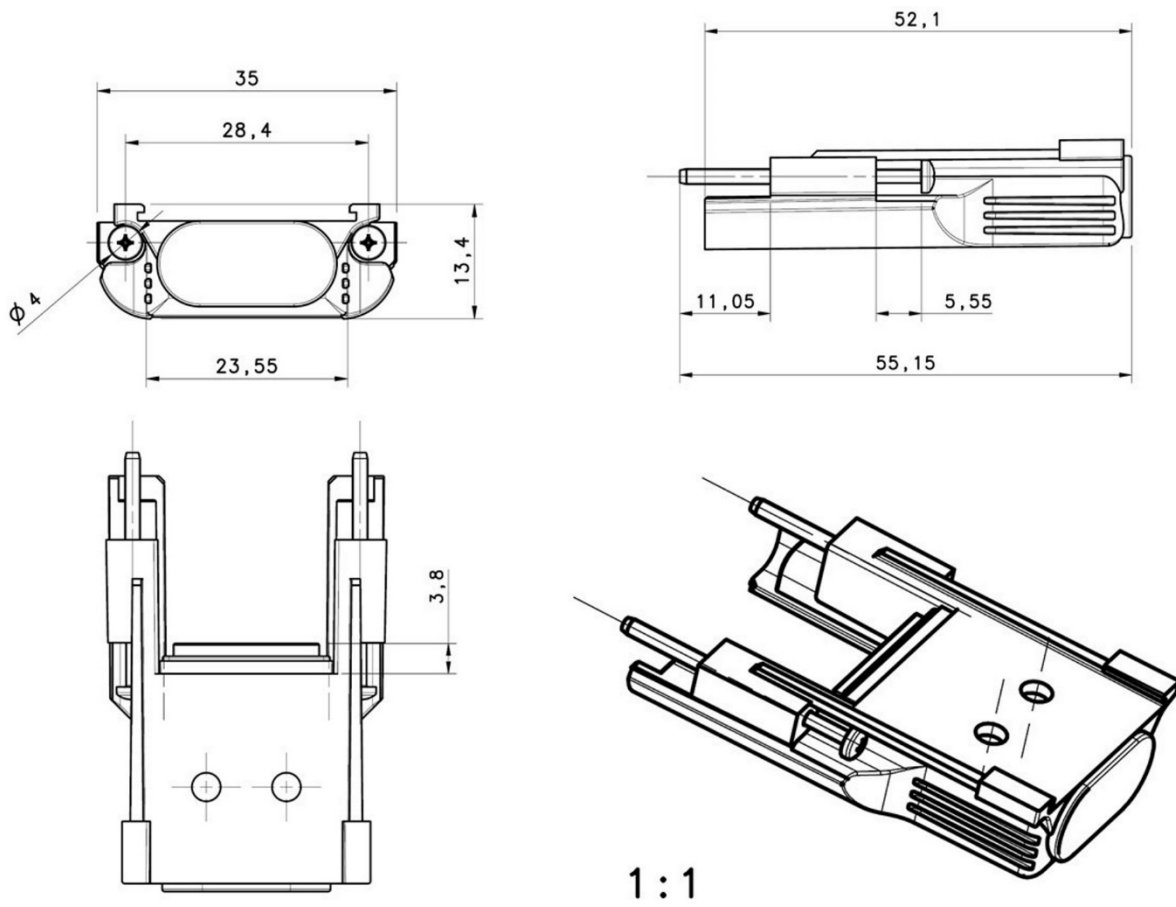

Fig 77 - Dimensions (mm)

14.2 TOOL FOR BCM CONFIGURATION

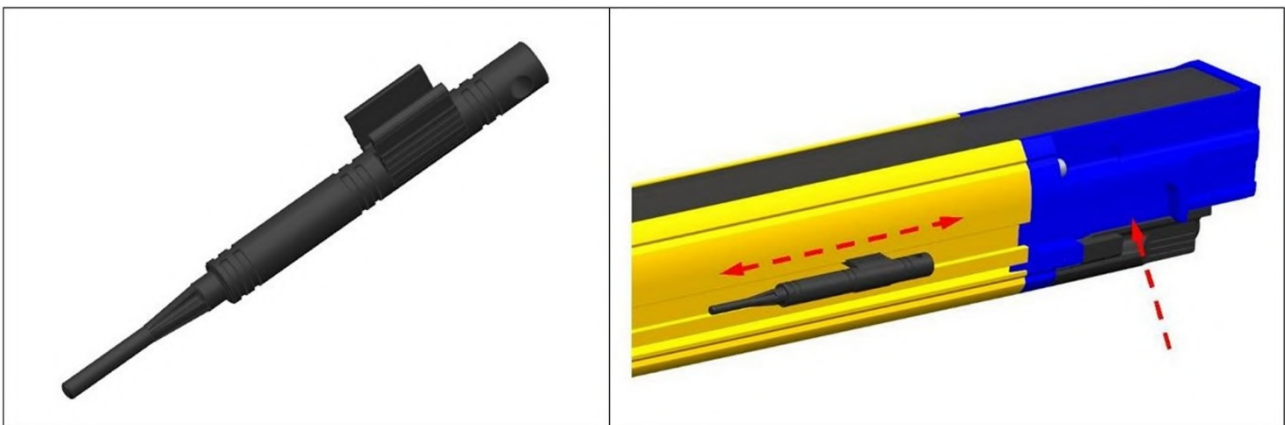

Fig 78 - Tool for BCM configuration

The tool for BCM configuration, when not used, can be inserted in the profile groove by making it enter from the top of the light curtain.

15 ACCESSORIES

(dimensions in mm)

15.1 (ST-KSTD) METAL ANGLED FIXING BRACKET

MODEL	DESCRIPTION	CODE
ST-KSTD	Angled fixing bracket (4 pcs kit)	95ACC1670

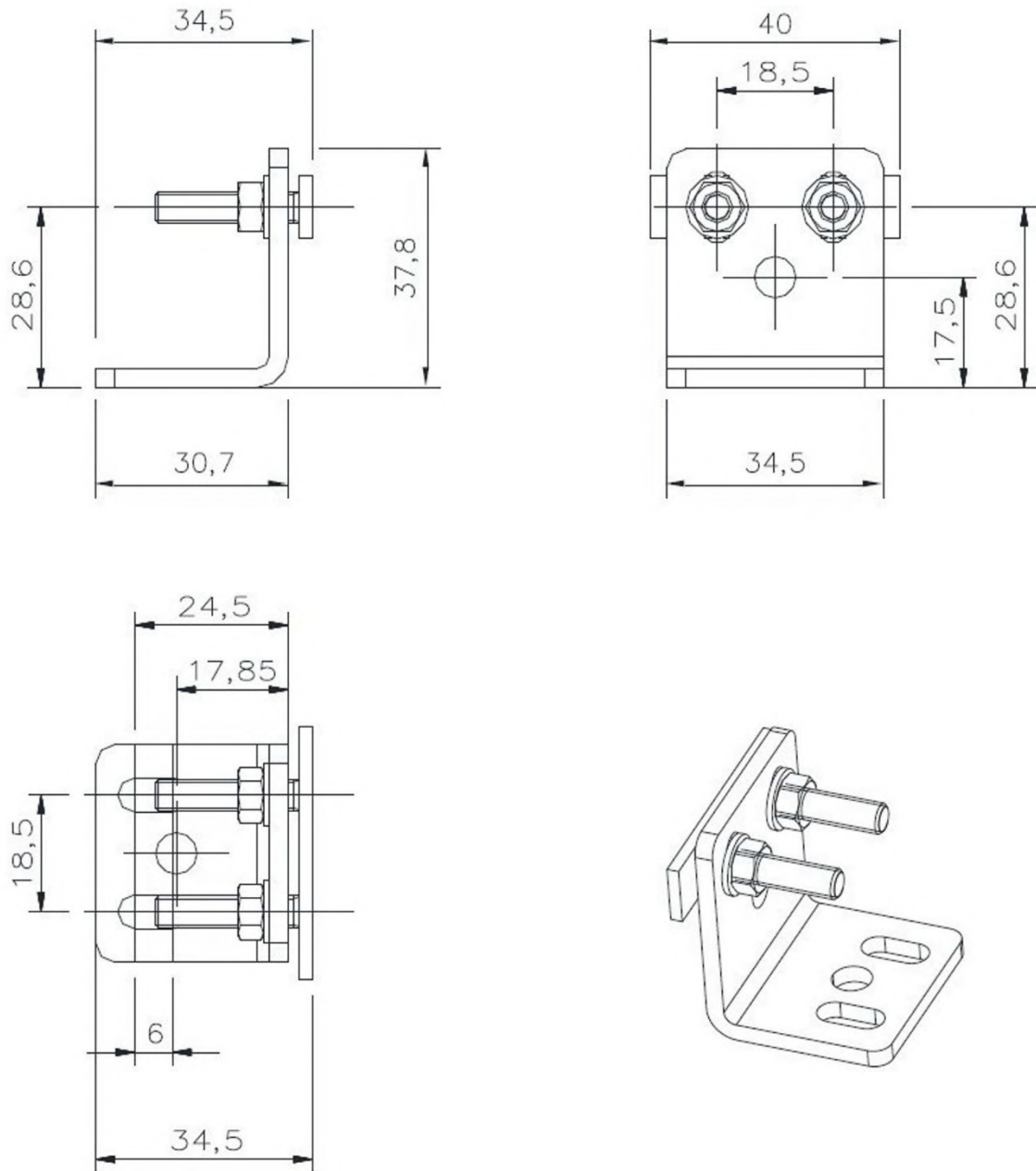

Fig 79 - ST-KSTD

Angled fixing bracket mounting with orientable and antivibration supports

MODEL	DESCRIPTION	CODE
ST-K4OR	Orientable supports (4 pcs kit)	95ACC1680
ST-K6OR	Orientable supports (6 pcs kit)	95ACC1690
ST-K4AV	Antivibration supports (4 pcs kit)	95ACC1700
ST-K6AV	Antivibration supports (6 pcs kit)	95ACC1710

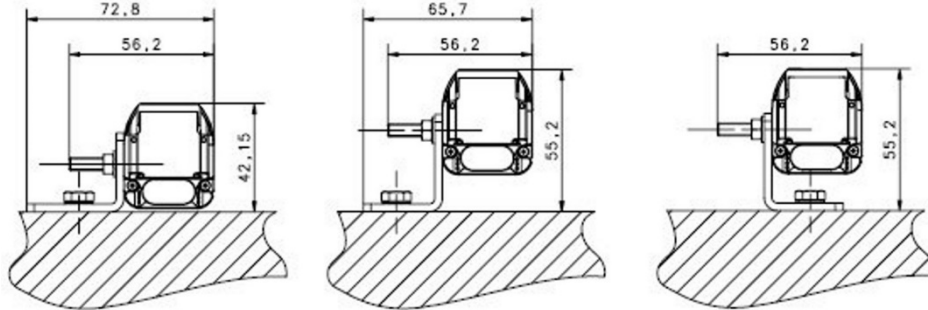

Fig 80 - Angled fixing bracket

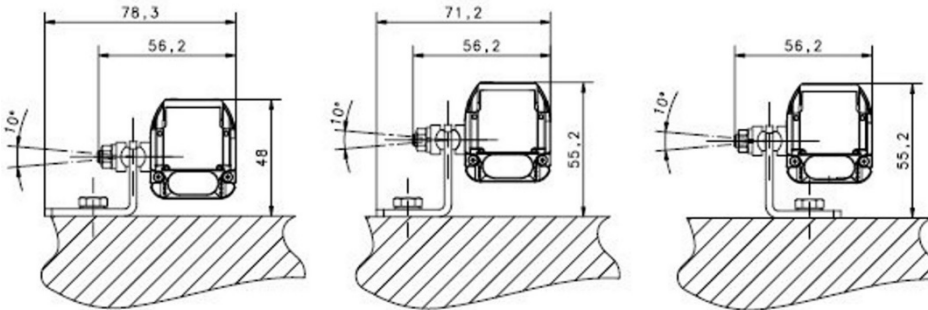

Fig 81 - Angled fixing bracket + Orientable support

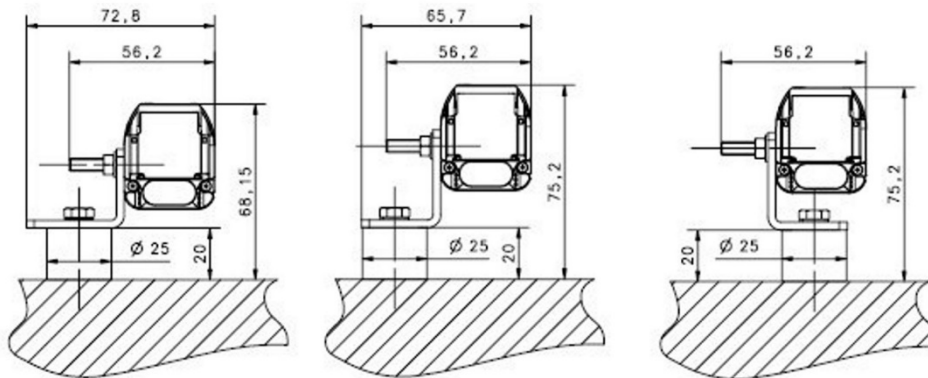

Fig 82 - Angled fixing bracket + Antivibration support

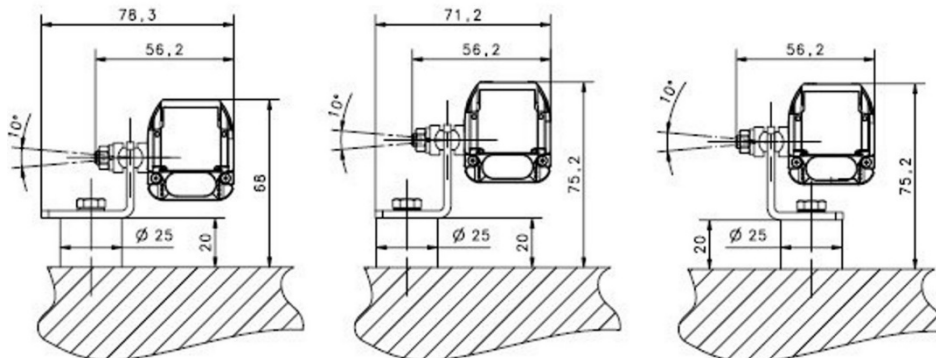

Fig 83 - Angled fixing bracket + Orientable support + Antivibration support

15.2 (ST-KPXMP) PLASTIC ANGLED FIXING BRACKET

MODEL	DESCRIPTION	CODE
ST-KP4MP	Angled fixing bracket (4 pcs kit)	95ASE1100
ST-KP6MP	Angled fixing bracket (6 pcs kit)	95ASE1110

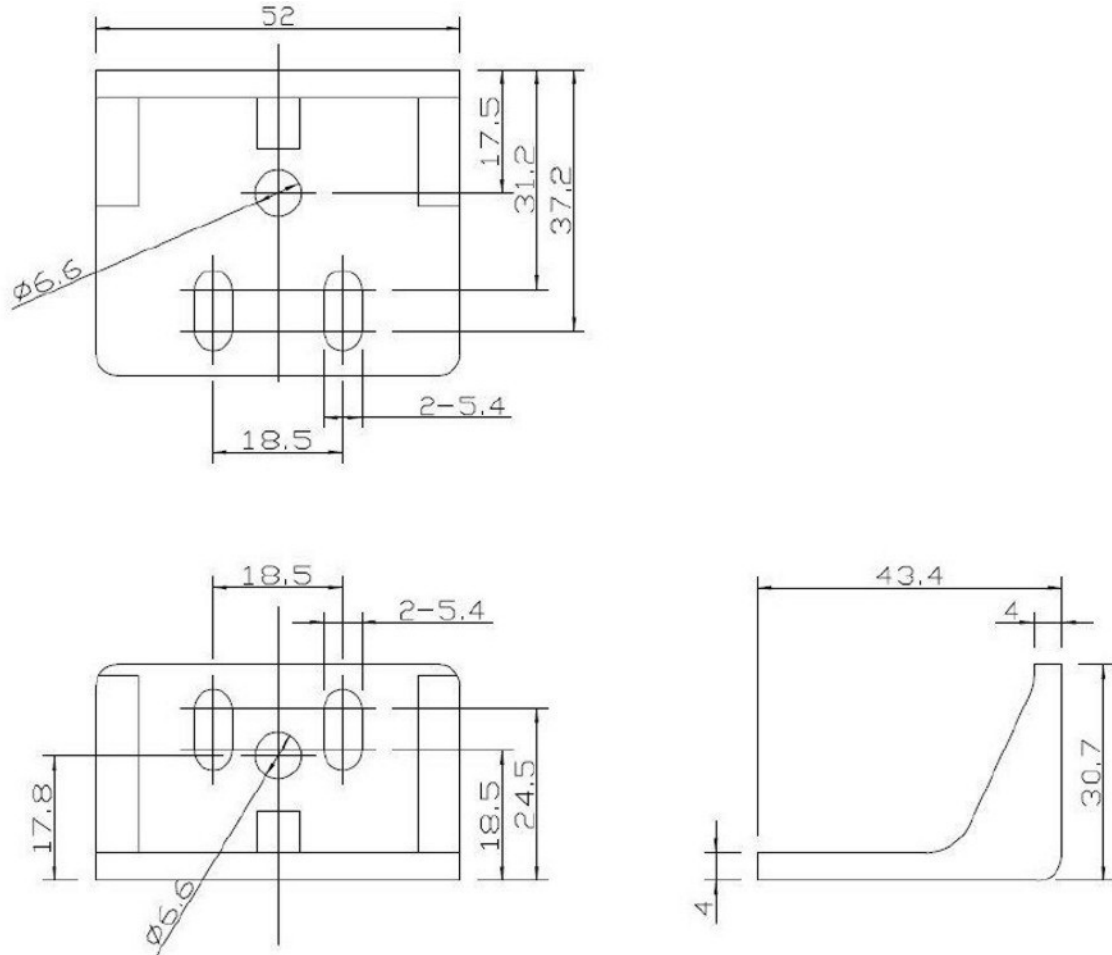

Fig 84 - ST-KPxMP

Angled fixing bracket mounting with orientable and antivibration supports

MODEL	DESCRIPTION	CODE
ST-K4OR	Orientable supports (4 pcs kit)	95ACC1680
ST-K6OR	Orientable supports (6 pcs kit)	95ACC1690
ST-K4AV	Antivibration supports (4 pcs kit)	95ACC1700
ST-K6AV	Antivibration supports (6 pcs kit)	95ACC1710

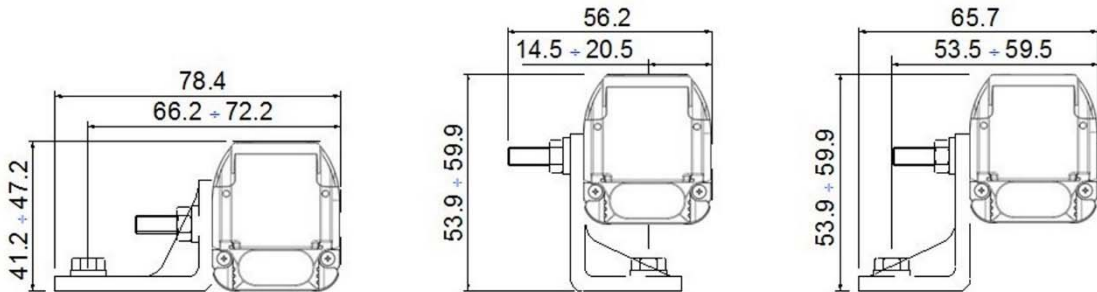

Fig 85 - Angled fixing bracket

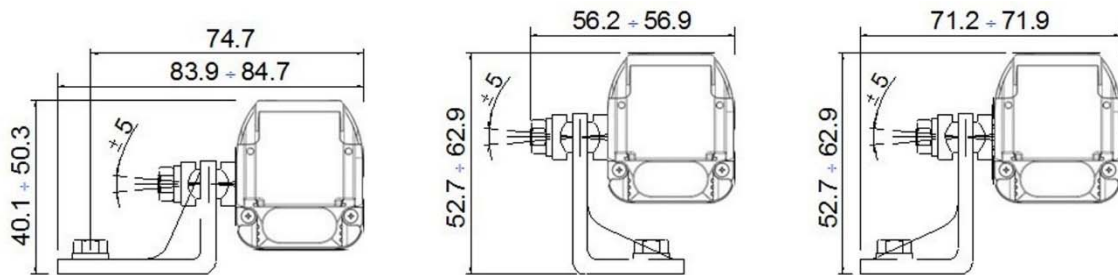

Fig 86 - Angled fixing bracket + Orientable support

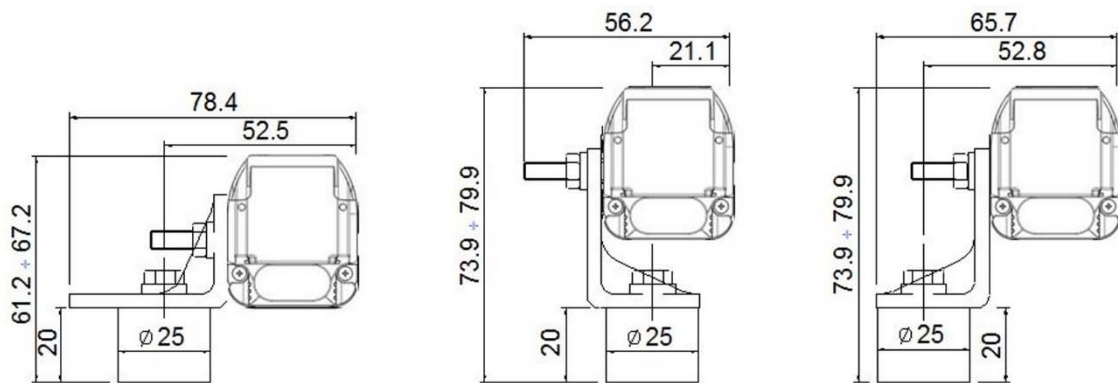

Fig 87 - Angled fixing bracket + Antivibration support

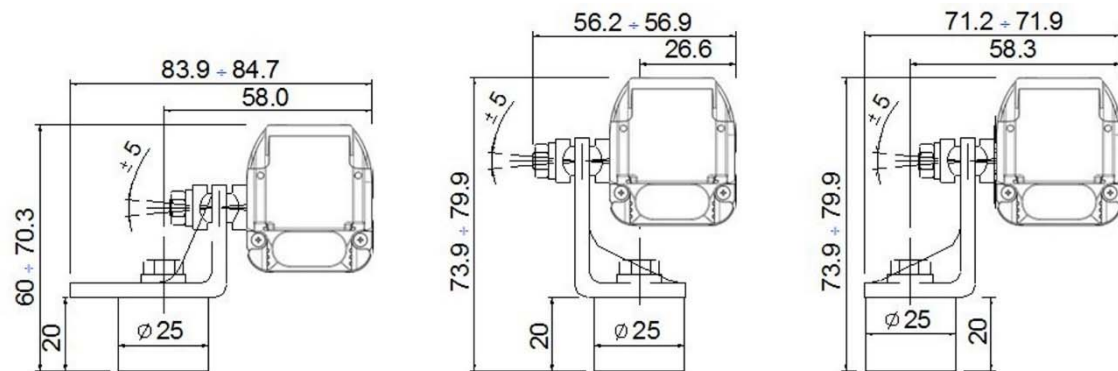

Fig 88 - Angled fixing bracket + Orientable support + Antivibration support

15.3 (SG-PSB) PROTECTIVE STANDS

MODEL	DESCRIPTION	L (mm)	CODE
SG-PSB 600	Protective stand H=600 mm	600	95ASE2240
SG-PSB 1000	Protective stand H=1000 mm	1000	95ASE2250
SG-PSB 1200	Protective stand H=1200 mm	1200	95ASE2260
SG-PSB 1650	Protective stand H=1650 mm	1650	95ASE2270
SG-PSB 1900	Protective stand H=1900 mm	1900	95ASE2280

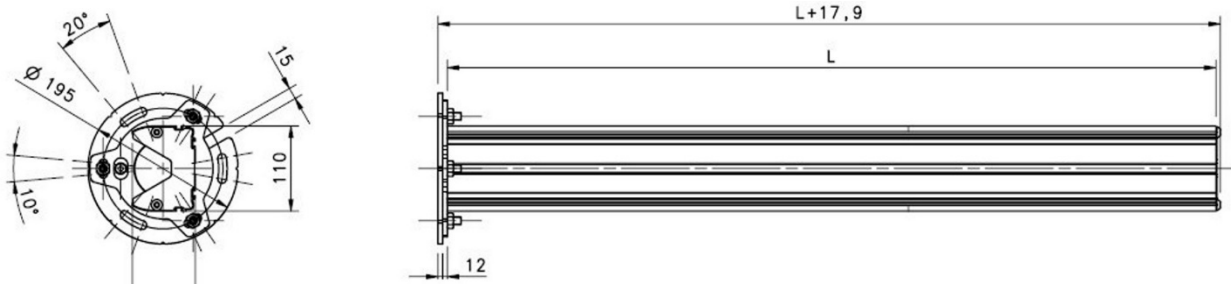

Fig 89 - Dimensions (mm)

Mounting kit

MODEL	DESCRIPTION	CODE
ST-PS4-SG-SE	Mounting kit (4 pcs kit)	95ASE1750
ST-PS6-SG-SE	Mounting kit (6 pcs kit)	95ASE1760

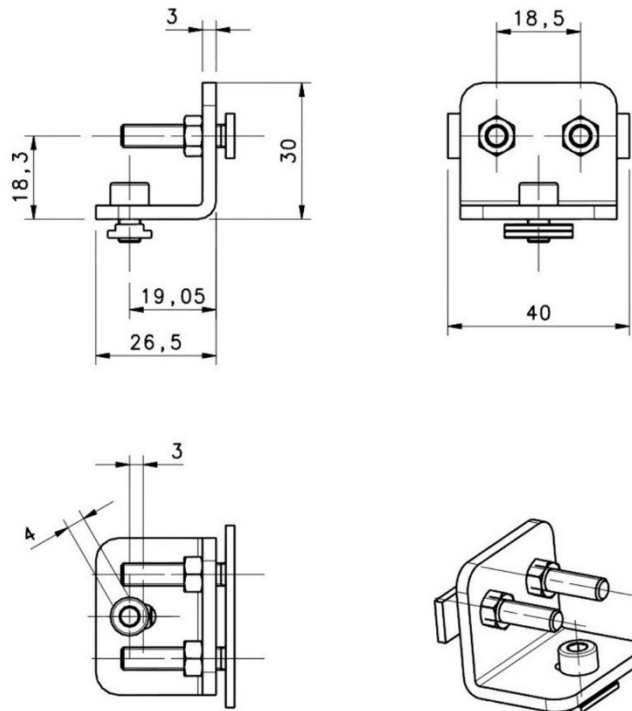

Fig 90 - Fixing kit

15.4 (SG-P) PLATE KIT FOR PROTECTIVE STANDS

MODEL	DESCRIPTION	CODE
SG-P	Plate kit with springs	95ASE2290

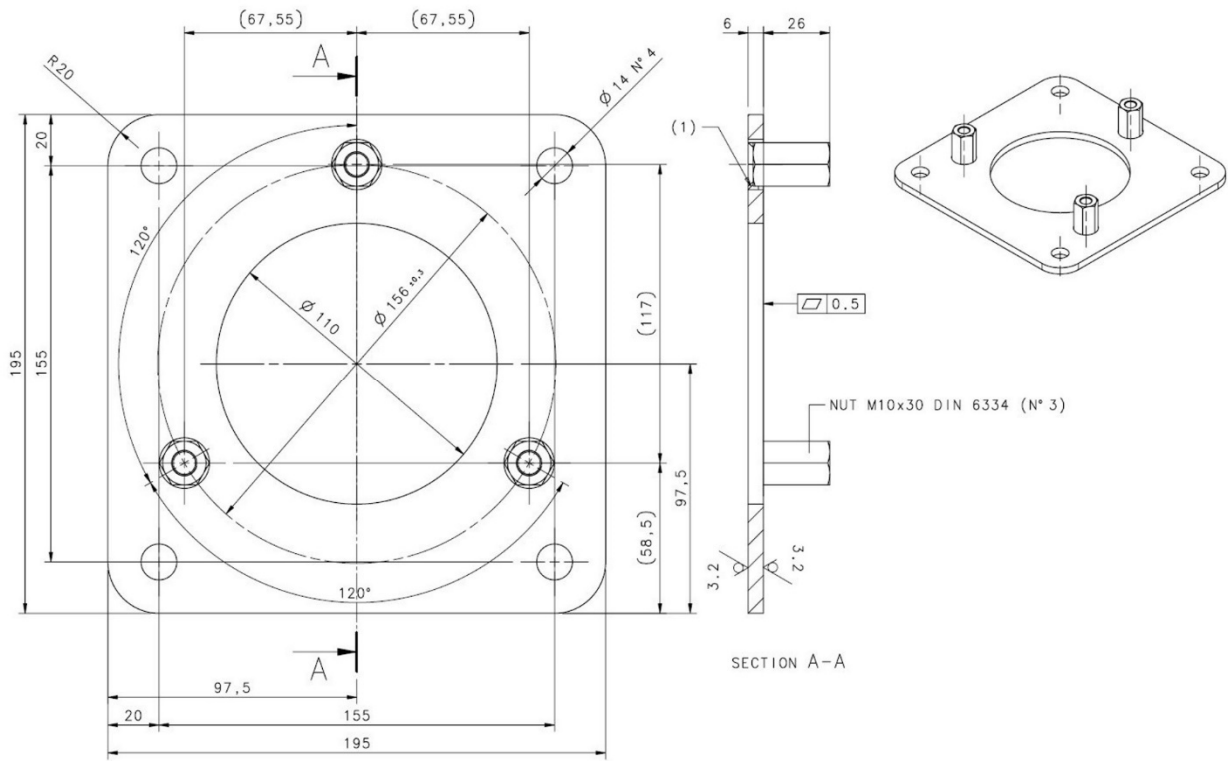

Fig 91 - Dimensions (mm)

Mounting with SG-PSB

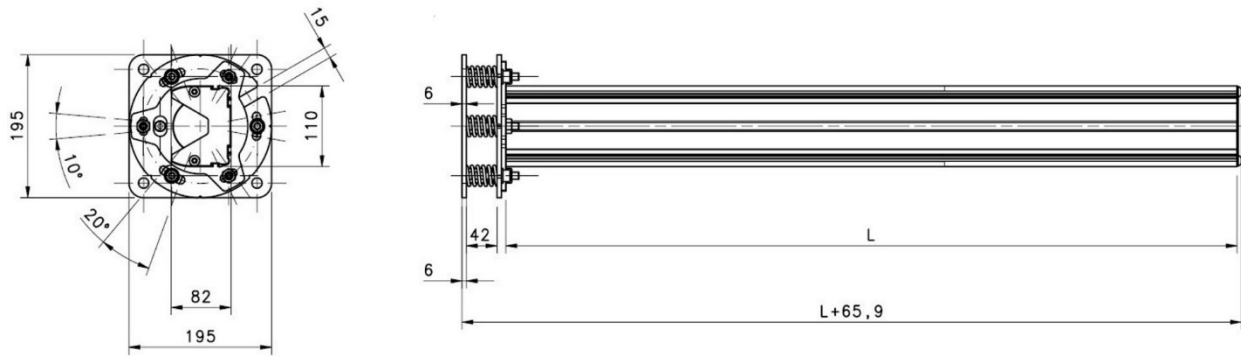

Fig 92 - Mounting

15.5 (SE-S) COLUMNS AND FLOOR STANDS

MODEL	DESCRIPTION	L(mm)	X (mm)	CODE
SE-S 800	Column and floor stand H= 800 mm	800	30x30	95ACC1730
SE-S 1000	Column and floor stand H= 1000 mm	1000	30x30	95ACC1740
SE-S 1200	Column and floor stand H= 1200 mm	1200	30x30	95ACC1750
SE-S 1500	Column and floor stand H= 1500 mm	1500	45x45	95ACC1760
SE-S 1800	Column and floor stand H= 1800 mm	1800	45x45	95ACC1770

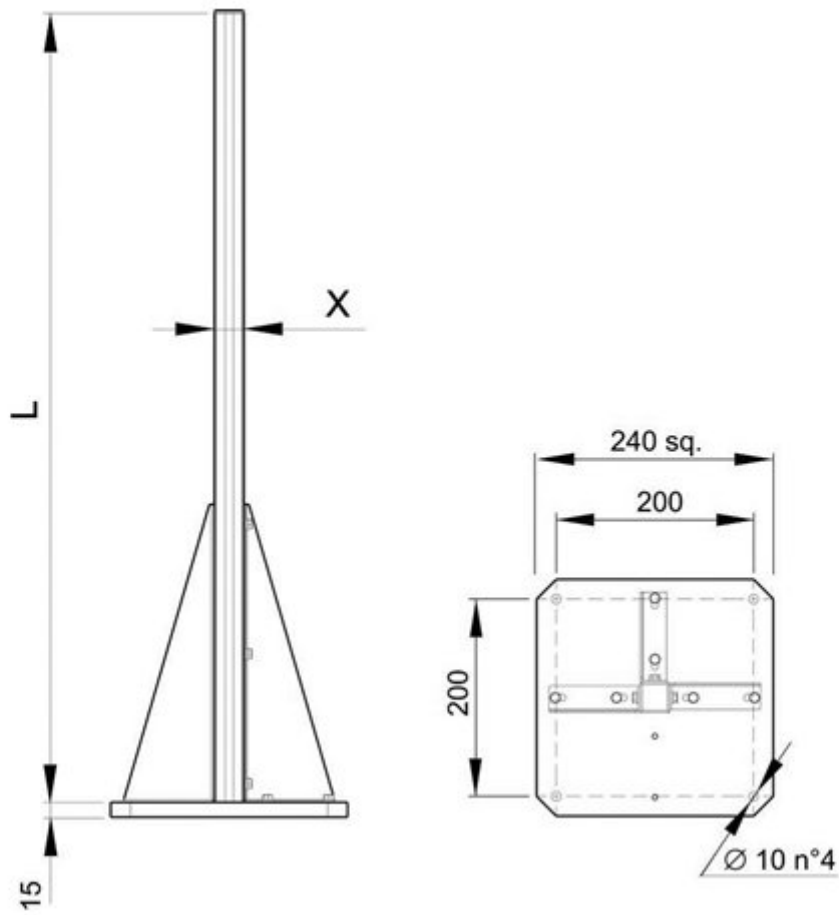

Fig 93 - Dimensions (mm)

15.6 (SG-DM) DEVIATING MIRRORS

MODEL	DESCRIPTION	L1 (mm)	L2 (mm)	L3 (mm)	CODE
SG-DM 600	Deviating mirror version 600 mm	545	376	580	95ASE1680
SG-DM 900	Deviating mirror version 900 mm	845	676	880	95ASE1690
SG-DM 1200	Deviating mirror version 1200 mm	1145	976	1180	95ASE1700
SG-DM 1650	Deviating mirror version 1650 mm	1595	1426	1630	95ASE1710
SG-DM 1900	Deviating mirror version 1900 mm	1845	1676	1880	95ASE1720

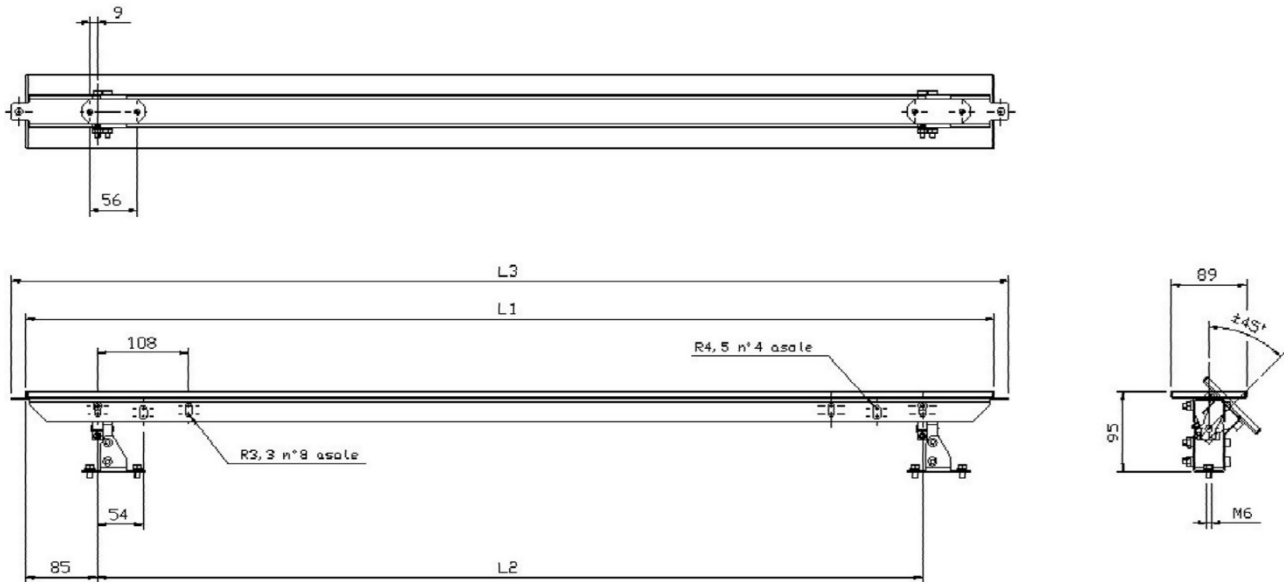

Fig 94 - Dimensions (mm)

The image includes the mirror SG-DM and a mounting kit ST-DM.

MODEL	DESCRIPTION	CODE
SG-DM 150	Deviating mirror version 150 mm	95ASE1670

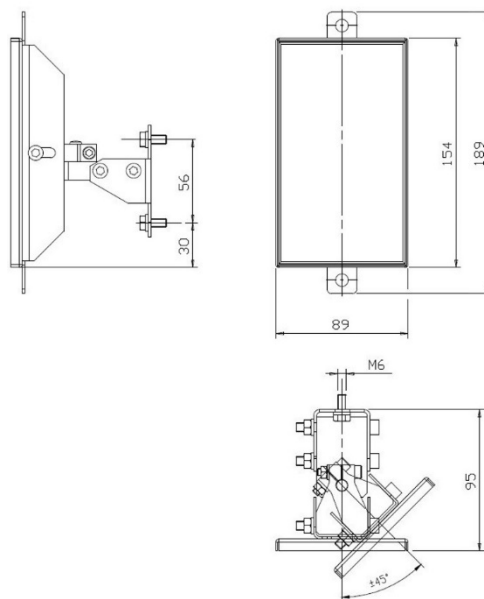

Fig 95 - SG-DM 150 Dimensions (mm)

The image includes the mirror SG-DM and a mounting kit ST-DM.

Mounting kit for SG-DM with SE-S column and floor stands

MODEL	DESCRIPTION	CODE
ST-DM	SG-DM mounting kit (2 pcs kit)	95ASE1940

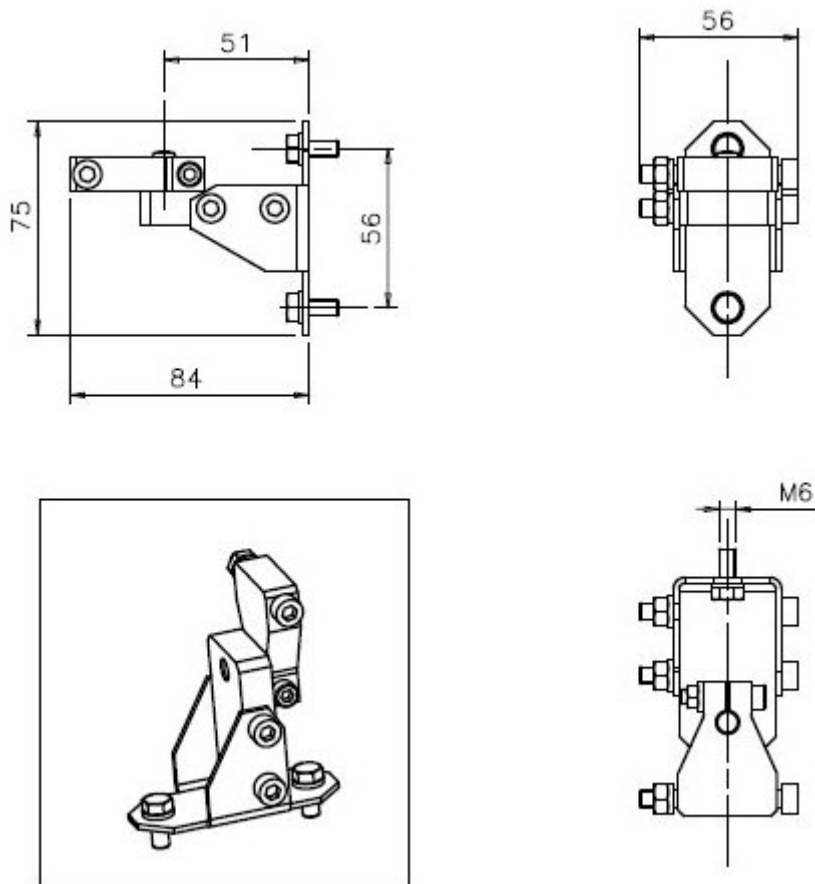

Fig 96 - Mounting kit

For each SG-DM mirror order 1 mounting kit ST-DM.

Mounting kit SG-DM on SG-PSB (ST-PS-DM)

MODEL	DESCRIPTION	CODE
ST-PS-DM	Deviating mirror SG-DM mounting kit (2 T-nuts)	95ASE1770

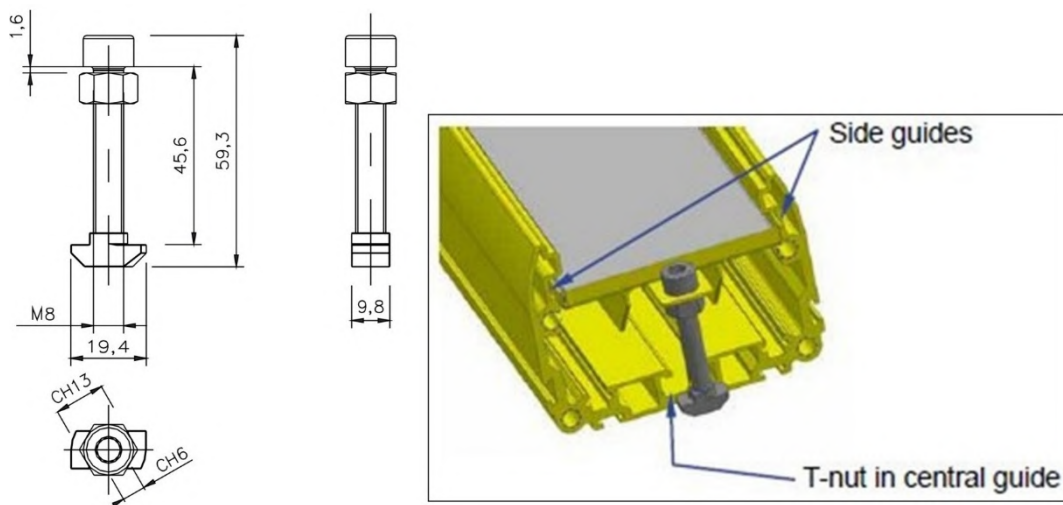

Fig 97 - Mounting kit

For each SG-DM mirror order 1 mounting kit ST-PS-DM.

15.7 (TP) TEST PIECE

MODEL	DESCRIPTION	CODE
TP-14	Test piece Ø 14mm L=300mm	95ACC1630
TP-20	Test piece Ø 20mm L=300mm	95ACC1640
TP-24	Test piece Ø 24mm L=200mm	95ASE2570
TP-30	Test piece Ø 30mm L=300mm	95ACC1650
TP-34	Test piece Ø 34mm L=200mm	95ASE2580
TP-35	Test piece Ø 35mm L=300mm	95ACC1660
TP-40	Test piece Ø 40mm L=300mm	95ACC1820
TP-50	Test piece Ø 50mm L=300mm	95ACC1790
TP-90	Test piece Ø 90mm L=300mm	95ACC1800

15.8 CONNECTION CABLES

5-pole M12 cables

MODEL	DESCRIPTION	CODE
CS-A1-03-U-03	5-pole M12 cable (axial) 3 m UL2464	95ASE1170
CS-A1-03-U-05	5-pole M12 cable (axial) 5 m UL2464	95ASE1180
CS-A1-03-U-10	5-pole M12 cable (axial) 10 m UL2464	95ASE1190
CS-A1-03-U-15	5-pole M12 cable (axial) 15 m UL2464	95ASE1200
CS-A1-03-U-25	5-pole M12 cable (axial) 25 m UL2464	95ASE1210
CS-A1-03-U-50	5-pole M12 cable (axial) 50 m UL2464	95A252700

12-pole M12 cables

MODEL	DESCRIPTION	CODE
CS-A1-10-U-03	12-pole M12 cable (axial) 3 m UL2464	95A252720
CS-A1-10-U-05	12-pole M12 cable (axial) 5 m UL2464	95A252730
CS-A1-10-U-10	12-pole M12 cable (axial) 10 m UL2464	95A252740
CS-A1-10-U-15	12-pole M12 cable (axial) 15 m UL2464	95A252750
CS-A1-10-U-25	12-pole M12 cable (axial) 25 m UL2464	95A252760
CS-A1-10-U-50	12-pole M12 cable (axial) 50 m UL2464	95A252770

15.9 PIGTAIL CABLES

TX - PIGTAIL CABLE

MODEL	DESCRIPTION	CODE
CS-G1-50-B-002	SG EXTENDED TX 0.2m	95A252820

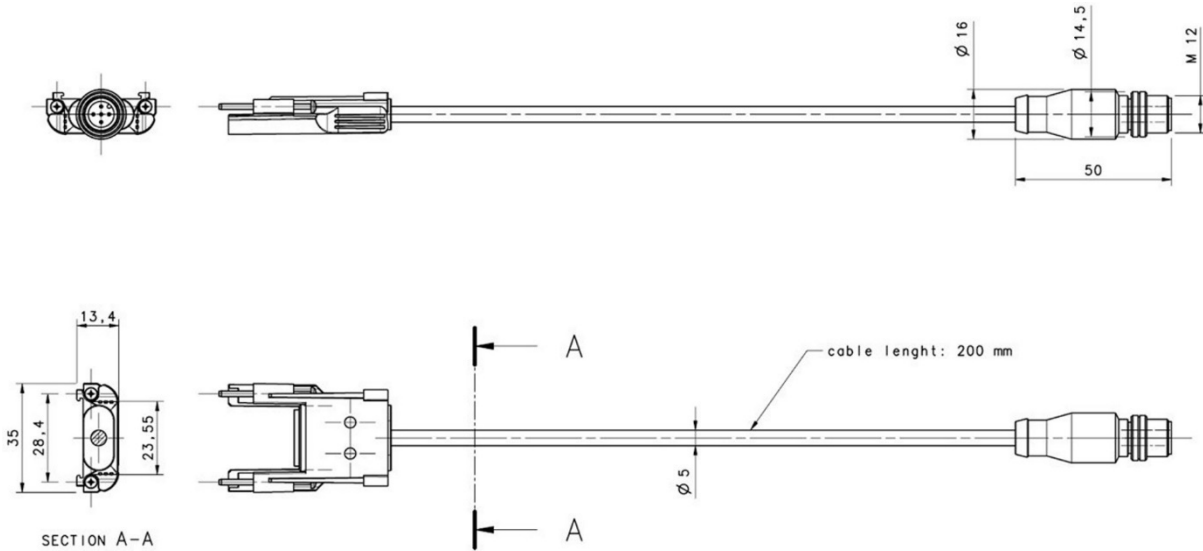

Fig 98 - TX - Pigtail cable

This is the Pig-Tail cable that must be always used for TX UNIT SG4 EXTENDED. It has a 18 poles socket in one side and a M12 5 poles in the other.

RX MUTING - PIGTAIL CABLE

MODEL	DESCRIPTION	CODE
CS-R1-75-B-002	SG EXTENDED RX MUTING 0.2m	95A252810

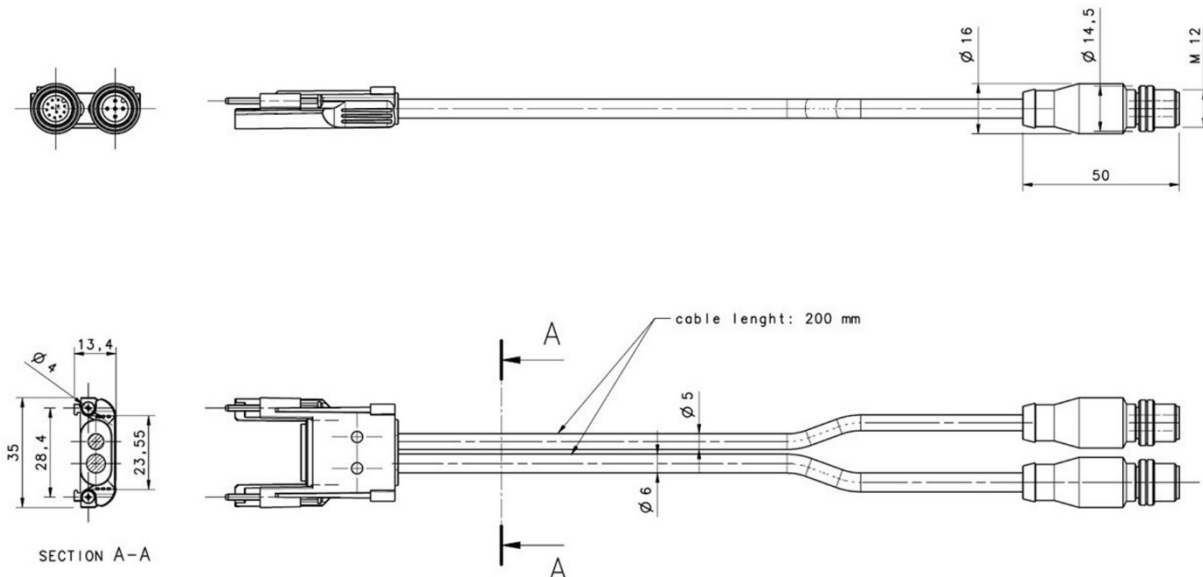

Fig 99 - RX MUTING - Pigtail cable

Presenta un connettore da 18 poli su un lato ed un M12 a 5 poli più un M12 a 12 poli sull'altro.

This is the Pig-Tail cable that must be always used for RX UNIT SG4 EXTENDED when you configure it in MUTING MODE and DON'T USE SG4-DONGLE. It has a 18 poles socket in one side and a M12 5 poles plus M12 12 poles in the other.

15.10 (SG-LP) LASER POINTER

MODEL	DESCRIPTION	CODE
SG-LP	Laser pointer	95ASE5590

The laser pointer of the SG-LP series represents a valid alignment and installation support for the safety light curtain series.

The pointer can be moved along the light curtain profile to verify the complete device alignment (top and bottom).

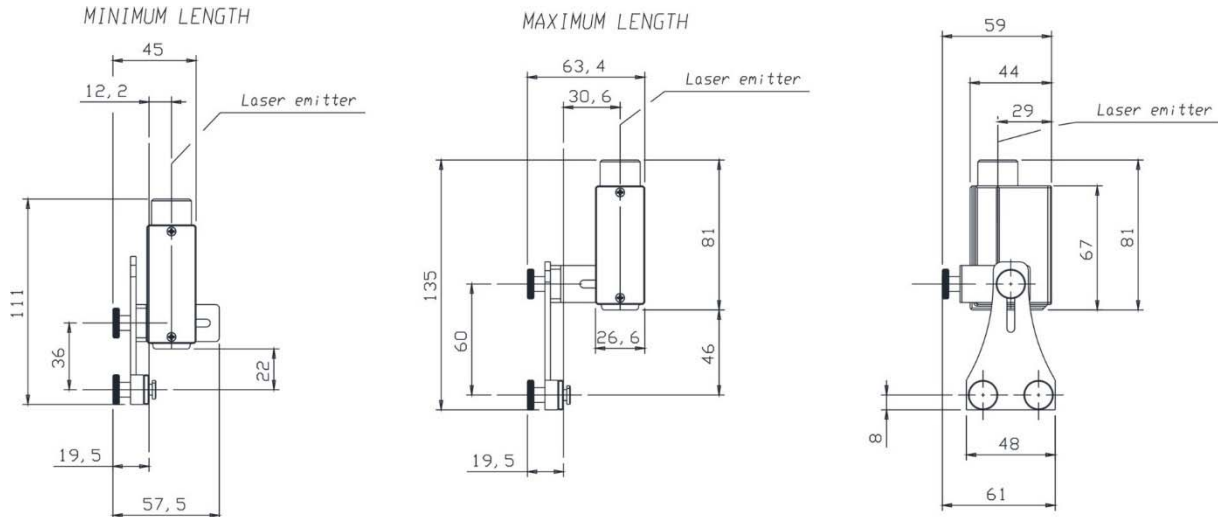

Fig 100 - Dimensions (mm)



Fig 101 - Laser pointer

15.11 (SE-SR2) SAFETY RELAY

15.12

MODEL	DESCRIPTION	CODE
SE-SR2	Type 4 safety relay - 3 NQ 1 NC	95ACC6170

The drawing show the connection between the safety light curtain and the Type 4 safety relay of the SE-SR2 series operating in the automatic Restart mode.

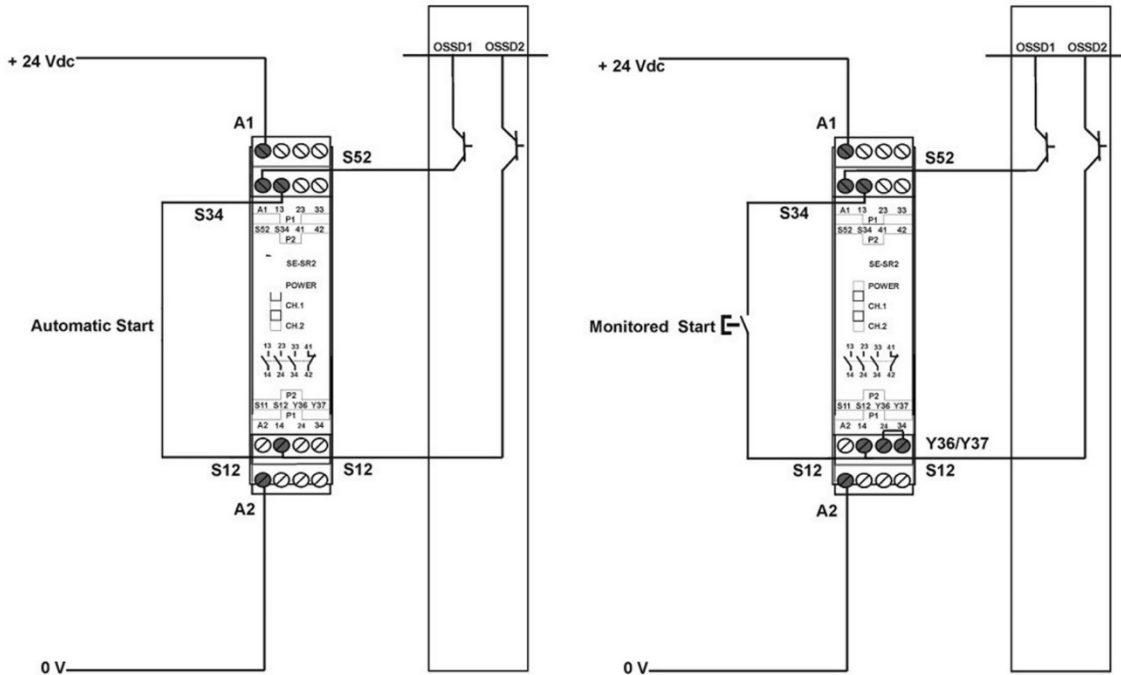

Fig 102 - Safety relay

15.13 (CSME-03VU24-Y14) EDM RELAY BOX

MODEL	DESCRIPTION	CODE
CSME-03VU24-Y14	EDM Relay	95ASE1270

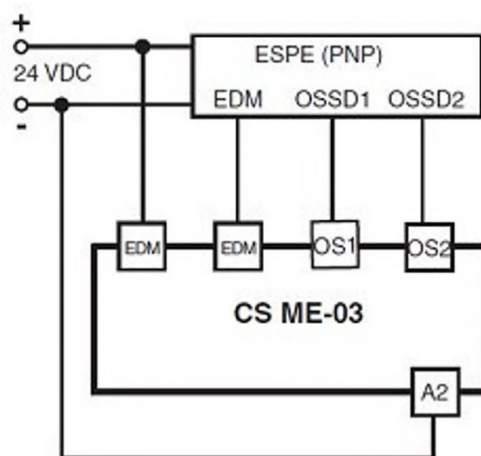

Fig 103 - EDM Relay

15.14 (LMS) MUTING LAMPS

MODEL	DESCRIPTION	CODE
LMS	Muting lamp	95ASE1830
LMS-1	Modular Muting lamp	95ACC1990
LMS-2	Muting lamp –horizontal mounting	95ACC2000
LMS-3	Muting lamp –vertical mounting	95ACC2010
SU-LMS-1A	Basic support for LMS-1	95ACC2020
SU-LMS-1B	Tower module for LMS-1	95ACC2030

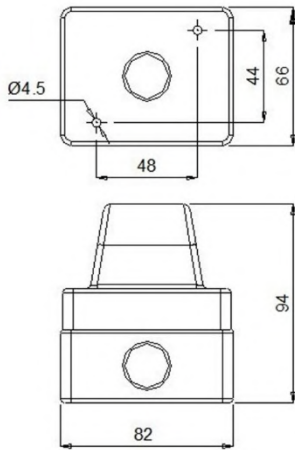

Fig 104 - Lamp LMS

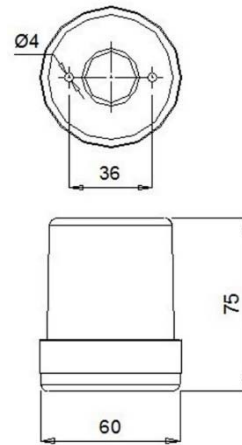

Fig 105 - Lamp LMS-2

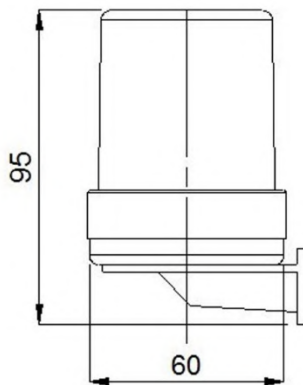

Fig 106 - Lamp LMS-3

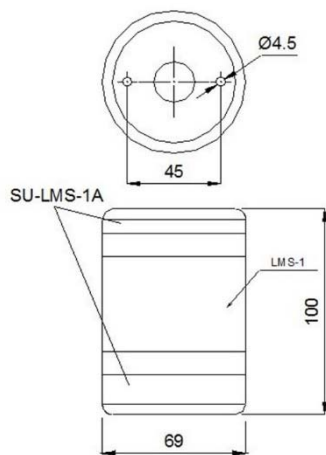
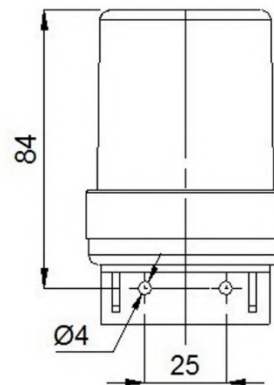

Fig 107 - Module SU-LMS-1A + LMS-1

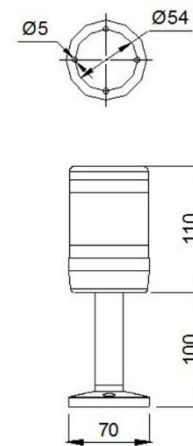

Fig 108 - Module SU-LMS-1B + LMS-1

15.15 SINGLE MUTING ARMS

MODEL	DESCRIPTION	CODE
SG-AS-ARM V2	Single active arm with RRX sensors V2	95ASE1841
SG-PR-ARM V2	Single passive arm with reflectors V2	95ASE1851
SG-F1-G1-ARMS	F1-G1 Muting arms	95ASE1880
SG-F2-G2-ARMS	F2-G2 Muting arms	95ASE1890

The SG4 EXTENDED and SG2 MUTING series light curtains can be equipped with retro-reflective Muting arms to obtain the “T” or “L” configuration.

The following figures show, respectively, the dimensions of single active arms, of single passive arms, and the corresponding fixing bracket stand alone.

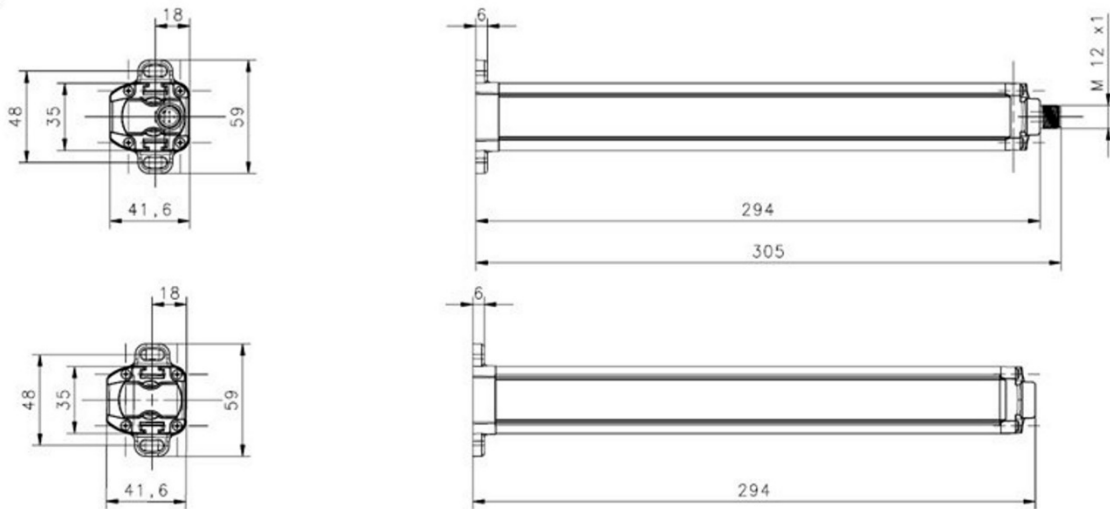

Fig 109 - Dimensions (mm)

MODEL	DESCRIPTION	CODE
SG-CB-C	Muting arms mounting bracket kit	95ASE1930

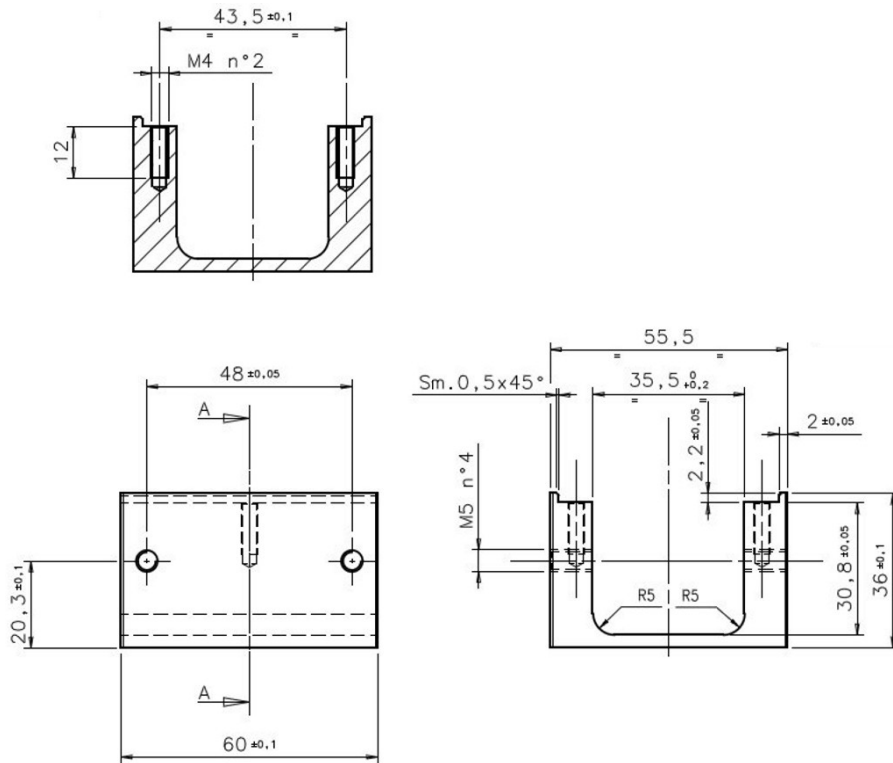

Fig 110 - Mounting bracket

To obtain a 'L' configuration with F/G arms use SG-F1-G1-ARMS together with 2 pieces of SG-CB-C.

Please install F1 arm on RX unit and G1 arm on TX in order to have them facing one to another.



To obtain a 'T' configuration with F/G arms use SG-F1-G1-ARMS and SG-F2-G2-ARMS together with 2 pieces of SG-CB-C.

Please install F1 and F2 arms on RX unit and G1 and G2 arms on TX in order to have them facing one to another.

15.16 DOUBLE MUTING ARMS

MODEL	DESCRIPTION	CODE
SG-L-ARMS V2	Active/Passive arms L couple V2	95ASE1861
SG-T-ARMS V2	Active/Passive arms T couple V2	95ASE1871

The following figures show, respectively, the dimensions of single active arms with fixing bracket mounted, of single passive arms with fixing bracket mounted, of double active arms with fixing bracket mounted, of double passive arms with fixing bracket mounted.

ACTIVE/PASSIVE ARMS L

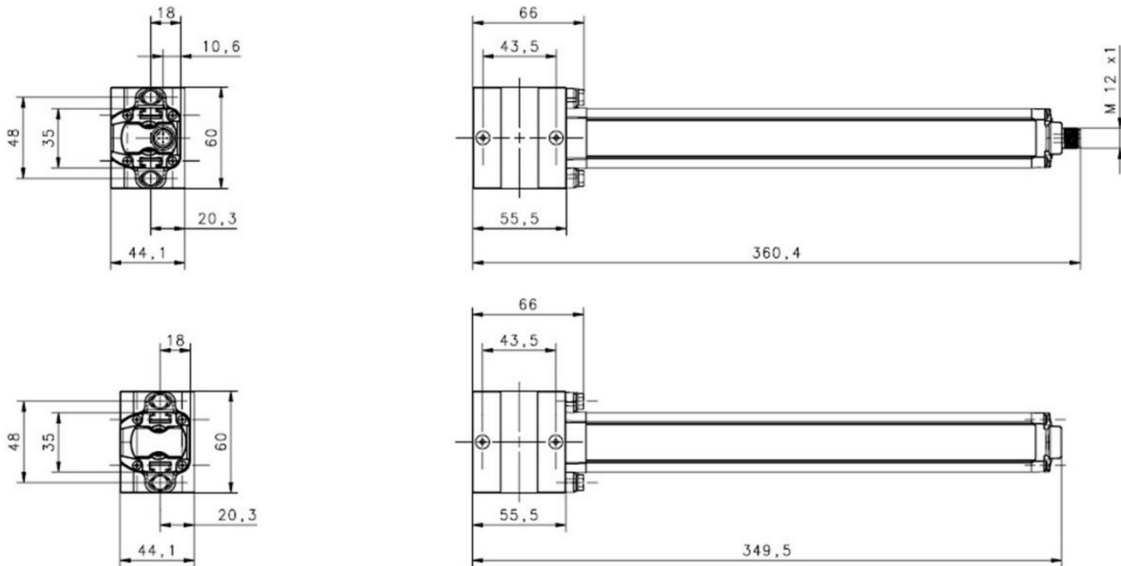

Fig 111 - Active/Passive arms L

ACTIVE/PASSIVE ARMS T

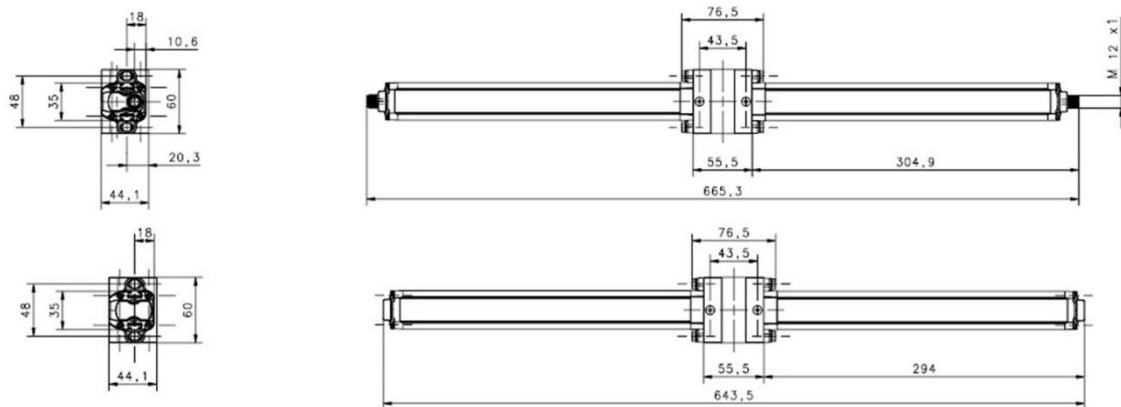

Fig 112 - Active/Passive arms T

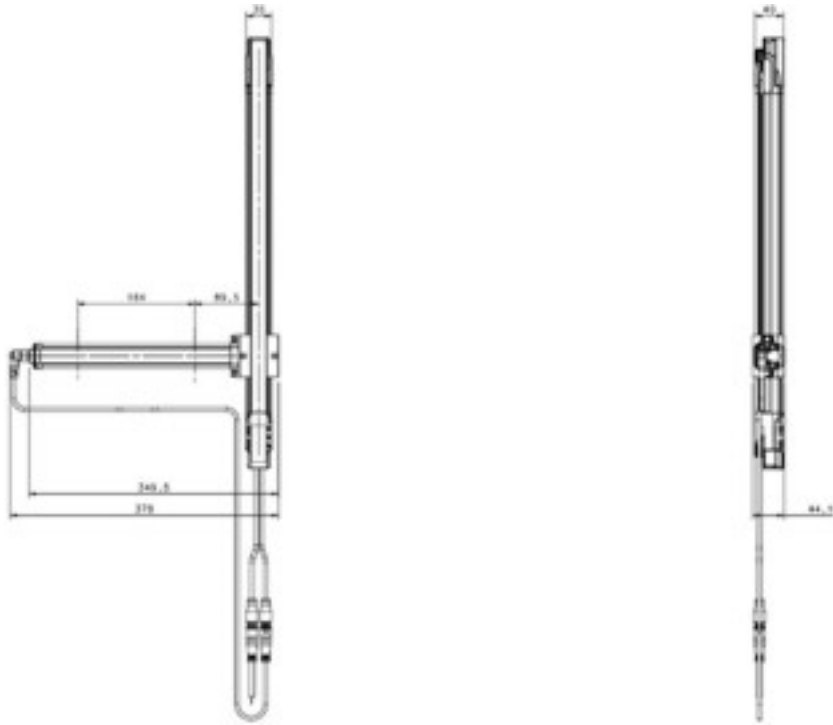

Fig 113 - Light curtain + Active/Passive arms L

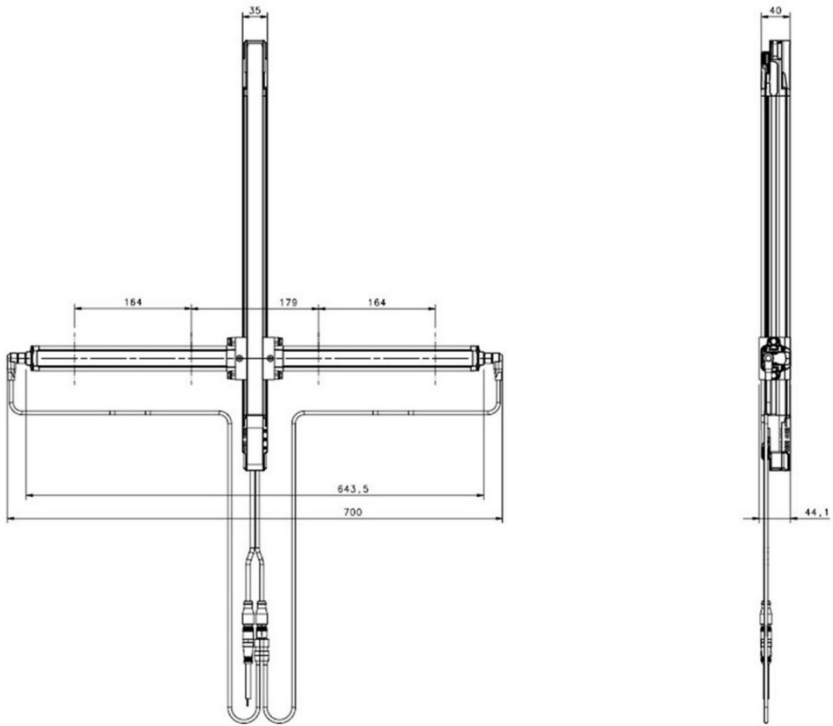

Fig 114 - Light curtain + Active/Passive arms T

15.17 (SG-M) MUTING ARMS WITH EXTERNAL SENSORS

System is compatible with all SG safety light curtains with muting function feature.

For correct use and safety prescriptions refer to the user manual of DATASENSING safety light curtains where muting kit is installed.

With muting modular systems is possible to arrange multiple configurations.

MODEL	DESCRIPTION	CODE
SG-ML-S8-L	Kit for L Muting, left side: 2 sensors S8-PR-5-B01-PP; 2 reflectors; 1 active arm; 1 passive arm; 2 cable-lockers; 2x 700mm cables with M12 connectors	95ASE2600
SG-ML-S8-R	Kit for L Muting, right side: 2 sensors S8-PR-5-B01-PP; 2 reflectors; 1 active arm; 1 passive arm; 2 cable-lockers; 2 x 700mm cables with M12 connectors	95ASE2370
SG-ML-S8-200-L	Kit for L Muting, left side: 2 sensors S8-PR-5-B01-PP; 2 reflectors; 1 active arm; 1 passive arm; 2 cable-lockers; 2 x 2000mm cables with M12 connectors	95ASE2590
SG-ML-S8-200-R	Kit for L Muting, right side: 2 sensors S8-PR-5-B01-PP; 2 reflectors; 1 active arm; 1 passive arm; 2 cable-lockers; 2 x 2000mm cables with M12 connectors	95ASE2340
SG-ML-S100-L	Kit for L Muting, left side: 2 sensors S100-PR-5-B10-PK; 2 reflectors; 1 active arm; 1 passive arm; 2 cable-lockers; 2x 700mm cables with M12 connectors	95ASE2620
SG-ML-S100-R	Kit for L Muting, right side: 2 sensors S100-PR-5-B10-PK; 2 reflectors; 1 active arm; 1 passive arm; 2 cable-lockers; 2x 700mm cables with M12 connectors	95ASE2430
SG-ML-S100-200-L	Kit for L Muting, left side: 2 sensors S100-PR-5-B10-PK; 2 reflectors; 1 active arm; 1 passive arm; 2 cable-lockers; 2 x 2000mm cables with M12 connectors	95ASE2610
SG-ML-S100-200-R	Kit for L Muting, right side: 2 sensors S100-PR-5-B10-PK; 2 reflectors; 1 active arm; 1 passive arm; 2 cable-lockers; 2 x 2000mm cables with M12 connectors	95ASE2400

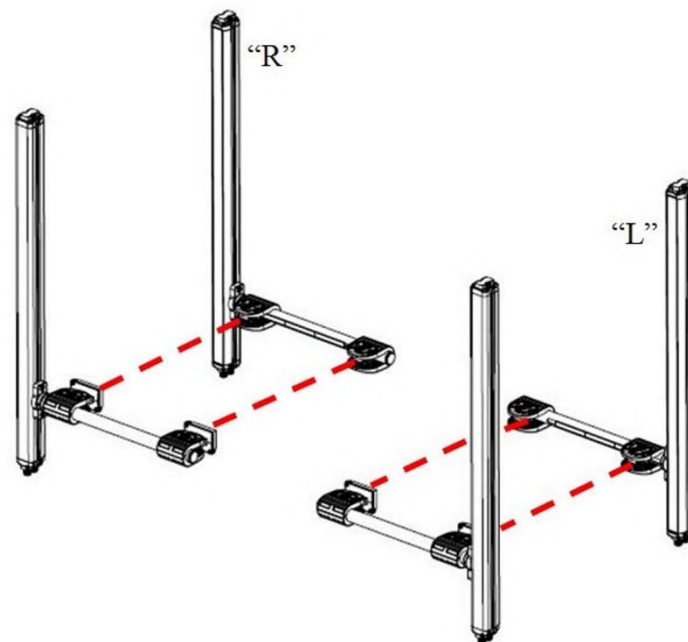

Fig 115 - L-MUTING

MODEL	DESCRIPTION	CODE
SG-MT-S8	Kit for T Muting: 4 sensors S8-PR-5-B01-PP; 4 reflectors; 2 active arms; 2 passive arms; 4 cable-lockers; 4 x 700mm cables with M12 connectors	95ASE2380
SG-MT-S8-200	Kit for T Muting: 4 sensors S8-PR-5-B01-PP; 4 reflectors; 2 active arms; 2 passive arms; 4 cable-lockers; 4 x 2000mm cables with M12 connectors	95ASE2350
SG-MT-S100	Kit for T Muting: 4 sensors S100-PR-5-B10-PK; 4 reflectors; 2 active arms; 2 passive arms; 4 cable-lockers; 4 x 700mm cables with M12 connectors	95ASE2440
SG-MT-S100-200	Kit for T Muting: 4 sensors S100-PR-5-B10-PK; 4 reflectors; 2 active arms; 2 passive arms; 4 cable-lockers; 4 x 2000mm cables with M12 connectors	95ASE2410

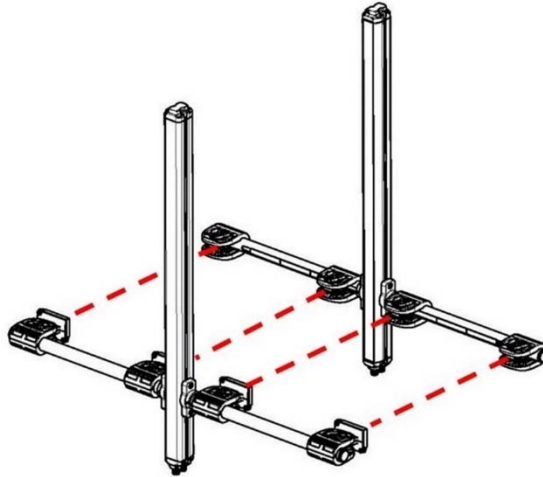

Fig 116 - T-MUTING

MODEL	DESCRIPTION	CODE
SG-MX-S8	Kit for X Muting; 2 sensors S8-PR-5-B01-PP; 2 reflectors; 2 active arms; 2 passive arms; 4 cable-lockers; 700mm pigtail cables with M12 connectors	95ASE2390
SG-MX-S8-200	Kit for X Muting; 2 sensors S8-PR-5-B01-PP; 2 reflectors; 2 active arms; 2 passive arms; 4 cable-lockers; 2000mm pigtail cables with M12 connectors	95ASE2360
SG-MX-S100	Kit for X Muting; 2 sensors S100-PR-5-B10-PK; 2 reflectors; 2 active arms; 2 passive arms; 4 cable-lockers; 700mm pigtail cables with M12 connectors	95ASE2450
SG-MX-S100-200	Kit for X Muting; 2 sensors S100-PR-5-B10-PK; 2 reflectors; 2 active arms; 2 passive arms; 4 cable-lockers; 2000mm pigtail cables with M12 connectors	95ASE2420

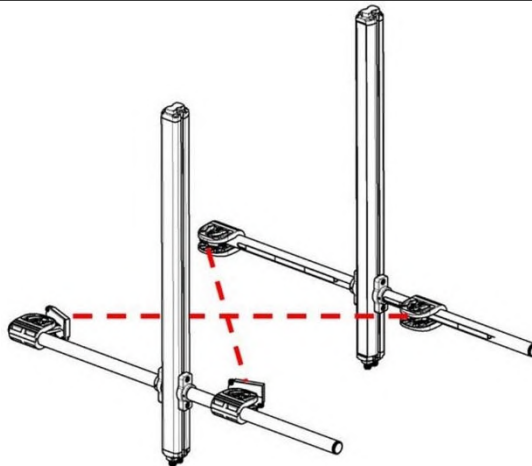

Fig 117 - X-MUTING

MOUNTING

- Put the arm slider (1) into the column slot (2).
- Fix the arm (3) in the desired position by screws (4), 1 Nm recommended tightening torque.

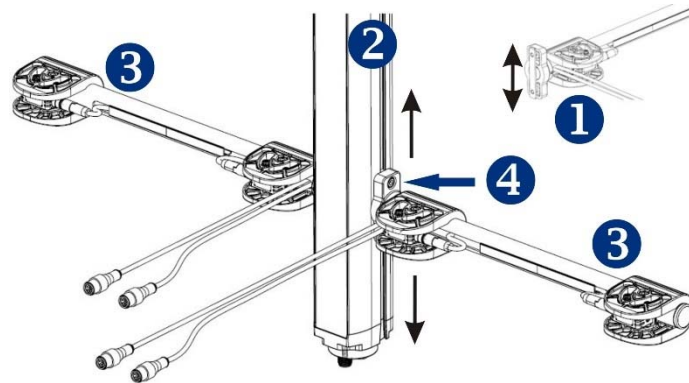

Fig 118 - Phase 1

- Rotate sensors/reflectors support (5) in the desired position ; if necessary, translate support removing and spacing cable-locker (6) and fix by screws (7), 2 - 3 Nm recommended tightening torque.

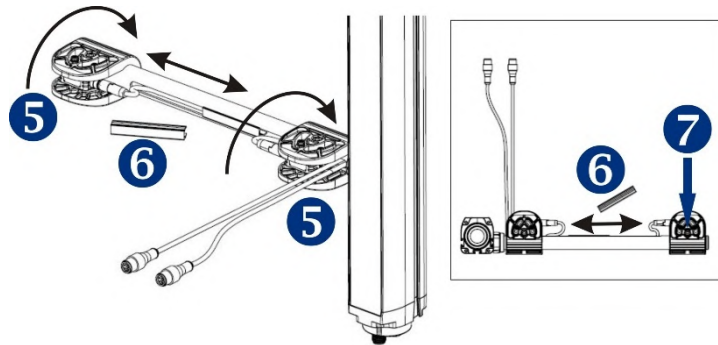

Fig 119 - Phase 2

- Loosen the two screws (8) and rotate/set the sensor/reflectors as desired, then fix by screws (8), 1 Nm recommended tightening torque.

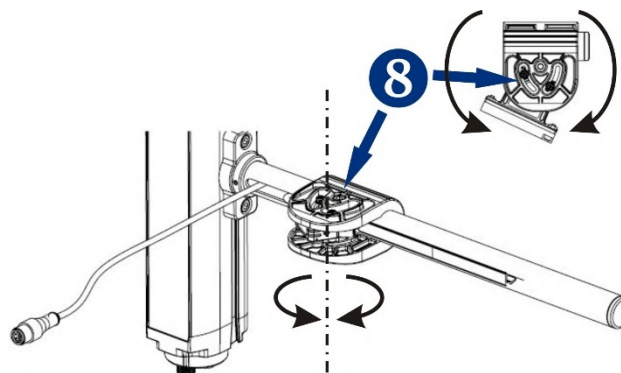

Fig 120 - Phase 3



For electrical link of SG-M kit to DATASENSING safety curtains, is recommended to use Datasensing Connection Box SG-M-CB.
 For each muting system kit is recommended to use same sensors type.
 Sensors must be set on Dark Mode.

15.18 (SG-M-CB) CONNECTION BOX

The SG-M-CB Connection box is part of SG-M accessories for muting, to be used with DATASENSING safety light curtains of SG series, with integrated muting function (e.g. SG BODY REFLECTOR MUTING).

Muting sensors can be connected to SG-M-CB Connection box via M12 cables.

The signals are connected to safety light curtain dedicated muting connector via approx. 0.5m long pigtail cable with M12 female connector.

Aside from the green LEDs* (to indicate sensors output status), the SG-M-CB does not contain any electronic elements and is therefore not subject to any safety classification.

Features:

- Supply and switching voltage +24V DC
- M12 connection
- Simple connection to safety light curtains

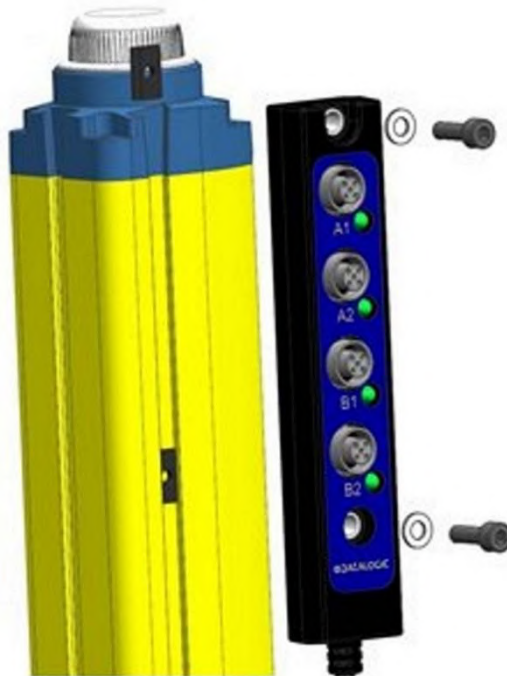

Fig 121 - Connection box



*** For correct operation of LED indicators, it is mandatory to connect identical sensors to the four M12 sockets.**

MODEL	DESCRIPTION	CODE
SG-M-CB	Connection box	95ASE2500
SG-M-CB-KIT	Mounting kit	95ASE2830

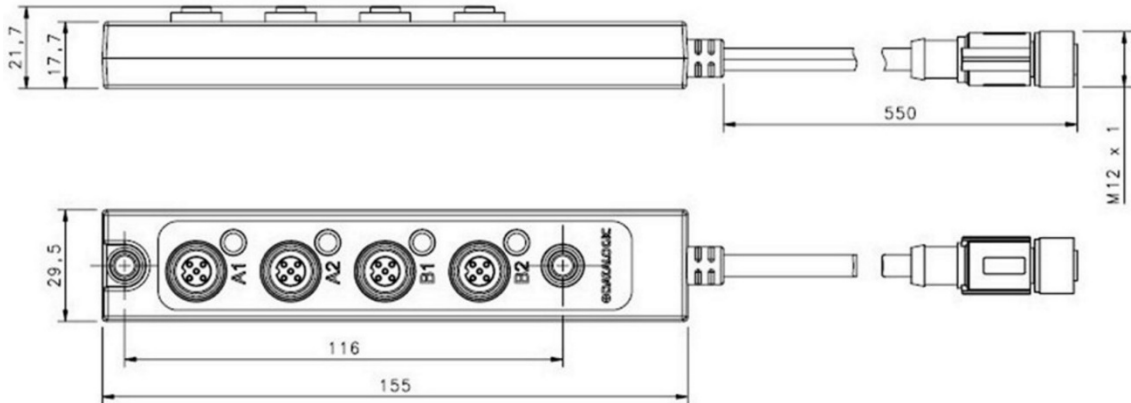

Fig 122 - Dimensions

Power supply & Switching voltage:	+24 Vcc ±20%
Current load max.:	1 A
Insulating resistance:	>1009 Ω
Mechanical protection:	IP 65
Operating temperature:	-10°C....+55°C
Storage Temperature:	-25°C....+70°C
Housing material:	PVC, Black (UL Recognized)
Housing Cable (C2):	PVC, Black (UL Recognized)
Housing Connector (C1):	Plug M12-5P A-Coding Female
Housing Connectors (A1;A2;B1;B2):	Sockets M12-5P A-Coding Female



For each muting system kit is recommended to use same sensors type.

15.19 (SG-SRT) CONNECTION BOX

The SG-SRT connection boxes are used to facilitate the connection and the use of barriers DATASENSING SG BODY MUTING Series.

The SG-SRT-1 box has externally:

- a key switch to activate the OVERRIDE function.
- a TEST / START button lit to implement the functions of Test, Restart, Reset.

The SG-SRT-2 box has externally:

- a key switch to activate the OVERRIDE function.
- a TEST / START button lit to implement the functions of Test, Restart, Reset.
- an integrated lamp for signaling Muting function activation



Fig 123 - SG-SRT-1



Fig 124 - SG-SRT-2

MODEL	DESCRIPTION	CODE
SG-SRT-1	Muting connection box	95ASE2050
SG-SRT-2	Muting connection box with lamp	95ASE2060

15.20 (SG-BWS) SAFETY CONTROL UNITS

MODEL	DESCRIPTION	CODE
SG-BWS-T4	Type 4 safety control unit	957051000
SG-BWS-T4-2	Type 4 safety control unit 4 - 8 single beam devices	957051030
SG-BWS-T4-MT	Type 4 control unit with double Muting	957051010
SG-BWS-T4-2-MT	Type 4 control unit with double Muting for up to 8 photocells	957051040

SG-BWS-T4 safety system consists of a control unit enclosed in a plastic housing to be installed on OMEGA/DIN rail equipped with 16 screw clamps that can be connected up to 4 sets of photocells of the S5-ST, SL5-ST, S300 series.



Fig 125 - SG-BWS-T4 Safety control unit

SG-BWS-T4-MT safety system consists of a control unit enclosed in a plastic housing, to be installed on OMEGA/DIN rail, equipped with 48 screw clamps that can be connected up to 4 sets of photocells of the S5-ST, SL5-ST, S300 series and to up to 2 safety light curtains.

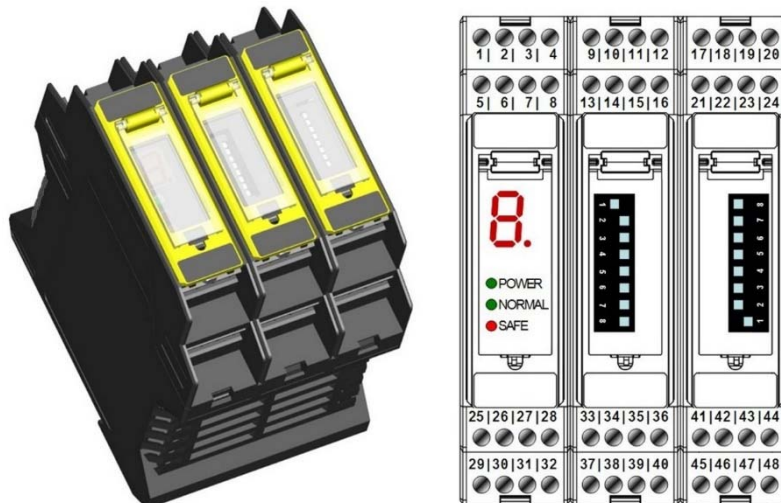

Fig 126 - SG-BWS-T4-MT Safety control unit

16 GLOSSARY

Detection zone: zone within which a specified test piece will be detected by the ESPE

Safety light curtain: it is an active optoelectronic protective device (AOPD) including an integrated system consisting of one or several emitting elements and one or several receiving elements forming a detection area with a detecting capacity specified by the supplier.

Detection capability (or Resolution): the minimum dimension which an opaque object must have in order to interrupt at least one beams of the ESPE whatever is position across the protected height.

Force-guided contacts: Relay contacts are force guided when they are mechanically connected so that they must switch simultaneously on input change.

If one contact of the series remains “welded”, no other relay contact is able to move.

That relay characteristic allows the use of EDM function.

OSSD (Output signal switching device): part of the ESPE connected to machine control system.

When the sensor is enabled during standard operating conditions, it switches to disabled status.

ESPE (Electro-sensitive protective equipment): assembly of devices and/or components working together to activate the protective disabling function or to detect the presence of something and including at least: a sensor, command/control devices and output signal switching devices.

AOPD (Active optoelectronic protective device): its detection function is achieved thanks to the use of optoelectronic receivers and emitters detecting the optical beams interruptions inside the device caused by an opaque object present inside the specified detecting area.

An active optoelectronic protective device (AOPD) can operate both in emitter-receiver mode and in retro-reflective light curtains.

Protective device: device having the function to protect the operator against possible risks of injury due to the contact with machine potentially-dangerous parts.

Min.installation distance: min. distance necessary to allow machine dangerous moving parts to completely stop before the operator can reach the nearest dangerous point. This distance shall be measured from the middle point of the detecting area to the nearest dangerous point. Factors affecting min. installation distance value are machine stop time, total safety system response time and light curtain resolution.

EDM (External device monitoring): device used by the ESPE to monitor the status of the external command devices.

MPCE (Machine primary control element): electrically-powered element having the direct control of machine regular operation so as to be the last element, in order of time, to operate when the machine has to be enabled or blocked.

Emitter (TX): unit emitting infrared beams, consisting of a set of optically-synchronised LEDs. The emitting unit, combined with the receiving unit (installed in the opposite position), generates an optical “curtain”, i.e. the detecting area.

Restart interlocking device (=RESTART): device preventing machine automatic restart after sensor activation during a dangerous phase of machine operating cycle, after a change of machine operating mode, and after a variation in machine start control devices.

Start interlocking device (= START): device preventing machine automatic start if the ESPE is live or the voltage is disabled and enabled once again.

Interlock: operating state of ESPE in Manual Restart Mode when all beams are free but the Restart command hasn't been received yet.

Normal Operation: operating state of ESPE when all beams are free, OSSD LED lit GREEN in SL light curtain OSSD1 and OSSD2 are switchen ON.

N.O.: normally opened

N.C.: normally closed

Machine operator: qualified person allowed to use the machine.

Qualified operator: a person who holds a professional training certificate or having a wide knowledge and experience and who is acknowledged as qualified to install and/or use the product and to carry out periodical test procedures.

Working point: machine position where the material or semifinished product is worked.

Receiver (RX): unit receiving infrared beams, consisting of a set of optically-synchronised phototransistors. The receiving unit, combined with the emitting unit (installed in the opposite position), generates an optical "curtain", i.e. the detecting area.

Crossing hazard: situation under which an operator crossing the area controlled by the safety device and this latter stops and keeps the machine stopped until the hazard is eliminated, and then enters the dangerous area. Now the safety device could not be able to prevent or avoid an unexpected restart of the machine with the operator still present inside the dangerous area.

Risk: probability of occurrence of an injury and severity of the injury itself.

Block condition (=BREAK): status of the light curtain taking place when a suitably-sized opaque object (see cfr.XREF-1:313) interrupts one or several light curtain beams.

Under these conditions, OSSD1 and OSS2 light curtain outputs are simultaneously switched OFF within the device response time.

Safe State: operating state of ESPE when at least one beam is intercepted, OSSD LED lit RED in [INLINE-1:44 light curtain. OSSD1 and OSSD2 are both switched OFF.

Response time: maximum time between the occurrence of the event leading to the actuation of the sensing device and the output signal switching devices (OSSD) achieving the OFF-state

Test piece: opaque object having a suitable size and used to test safety light curtain correct operation.

Type (of ESPE): the Electro-sensitive Protective Equipment (ESPE) have different reactions in case of faults or under different environmental conditions.

The classification and definition of the "type" (ex. type 2, type 4, according to EN 61496-1: 2013) defines the minimum requirements needed for ESPE design, manufacturing and testing.

Dangerous area: area representing an immediate or imminent physical hazard for the operator working inside it or who could get in contact with it.

Fig 1 - Safety light curtain 6

Fig 2 - Detection capability..... 10

Fig 3 - Detection Zone..... 11

Fig 4 - Installation distance (vertical positioning)..... 12

Fig 5 - Installation distance (horizontal positioning) 13

Fig 6 - Automatic packaging machines 14

Fig 7 - Presses and punching machines 14

Fig 8 - Benders and cutters..... 14

Fig 9 - Wrong light curtain positioning..... 17

Fig 10 - Correct light curtain positioning..... 17

Fig 11 - Wrong light curtain positioning..... 17

Fig 12 - Correct light curtain positioning..... 17

Fig 13 - Distance from reflecting surfaces..... 18

Fig 14 - Minimum distance from reflective surface..... 19

Fig 15 - Distance between homologous devices..... 20

Fig 16 - ESPE Type2 20

Fig 17 - Recommended positioning for homologous devices..... 21

Fig 18 - Wrong light curtain TX-RX orientations..... 22

Fig 19 - Use of deviating mirrors..... 23

Fig 20 - Path of the test piece 24

Fig 21 - Fixed brackets mounting procedure..... 25

Fig 22 - Anti-vibration dampers 25

Fig 23 - Light curtain dimensions 26

Fig 24 - Conessioni 27

Fig 25 - Pigtail cable - Muting configuration for receiver RX (CS-R1-75-B-002) 27

Fig 26 - Pigtail cable - configuration for emitter TX (CS-G1-50-B-002) 27

Fig 27 - M12 Connectors pinout..... 28

Fig 28 - Muting configuration..... 28

Fig 29 - Muting configuration receiver..... 28

Fig 30 - Configuration emitter..... 28

Fig 31 - Connection to SE-SR2 Safety Relais..... 29

Fig 32 - OSSDs connection..... 30

Fig 33 - Behaviour of OSSDs..... 30

Fig 34 - Description of the beams 31

Fig 35 - Alignment timings..... 31

Fig 36 - Alignment status 32

Fig 37 - User interface..... 33

Fig 38 - RX Function list..... 35

Fig 39 - Partial Muting selection..... 35

Fig 40 - TX Function list 35

Fig 41 - Restart timings (auto)..... 36

Fig 42 - Restart connection (auto)..... 36

Fig 43 - Restart timings (manual) 37

Fig 44 - Restart connection (manual)..... 37

Fig 45 - Restart Mode 37

Fig 46 - Test timings 38

Fig 47 - Reset timings 39

Fig 48 - PNP configuration 40

Fig 49 - EDM timings (PNP configuration) 40

Fig 50 - EDM connection (PNP configuration) 41

Fig 51 - EDM Selection 41

Fig 52 - Reduction range..... 42

Fig 53 - Reduction Range 42

Fig 54 - L-shaped version with integrated Muting sensors for unidirectional Muting 43

Fig 55 - T-shaped version with integrated Muting sensors for bidirectional Muting 43

Fig 56 - Linear version with external Muting sensors 43

Fig 57 - Typical Muting Application 44

Fig 58 - T Muting timings..... 45

Fig 59 - Muting T connection..... 46

Fig 60 - Muting L timings..... 46

Fig 61 - Muting L connection..... 47

Fig 62 - Muting Direction 47

Fig 63 - Muting timeout 48

Fig 64 - Muting timeout 48

Fig 65 - Partial Muting Selection 49

Fig 66 - Override connection..... 50

Fig 67 - Override attention status..... 50

Fig 68 - Override timings (level trigger) 51

Fig 69 - Override timings (edge trigger) 51

Fig 70 - Override Mode 51

Fig 71 - Override timeout timings 52

Fig 72 - User interface (RX) 53

Fig 73 - User interface (RX) 54

Fig 74 - User interface (TX)..... 55

Fig 75 - Overall dimensions (mm) 61

Fig 76 - Dimensions (mm)..... 62

Fig 77 - Dimensions (mm)..... 63

Fig 78 - Tool for BCM configuration 63

Fig 79 - ST-KSTD 64

Fig 80 - Angled fixing bracket..... 65

Fig 81 - Angled fixing bracket + Orientable support 65

Fig 82 - Angled fixing bracket + Antivibration support..... 65

Fig 83 - Angled fixing bracket + Orientable support + Antivibration support..... 65

Fig 84 - ST-KPxMP 66

Fig 85 - Angled fixing bracket..... 67

Fig 86 - Angled fixing bracket + Orientable support 67

Fig 87 - Angled fixing bracket + Antivibration support..... 67

Fig 88 - Angled fixing bracket + Orientable support + Antivibration support..... 67

Fig 89 - Dimensions (mm)..... 68

Fig 90 - Fixing kit..... 68

Fig 91 - Dimensions (mm)..... 69

Fig 92 - Mounting 69

Fig 93 - Dimensions (mm)..... 70

Fig 94 - Dimensions (mm)..... 71

Fig 95 - SG-DM 150 Dimensions (mm) 71

Fig 96 - Mounting kit..... 72

Fig 97 - Mounting kit..... 72

Fig 98 - TX - Pigtail cable..... 75

Fig 99 - RX MUTING - Pigtail cable 75

Fig 100 - Dimensions (mm)..... 76

Fig 101 - Laser pointer..... 76

Fig 102 - Safety relay 77

Fig 103 - EDM Relay.....	77
Fig 104 - LampLMS	78
Fig 105 - Lamp LMS-2	78
Fig 106 - LampLMS-3	78
Fig 107 - Module SU-LMS-1A + LMS-1	78
Fig 108 - Module SU-LMS-1B + LMS-1	78
Fig 109 - Dimensions (mm).....	79
Fig 110 - Mounting bracket	80
Fig 111 - Active/Passive arms L.....	81
Fig 112 - Active/Passive arms T	81
Fig 113 - Light curtain + Active/Passive arms L	82
Fig 114 - Light curtain + Active/Passive arms T	82
Fig 115 - L-MUTING	83
Fig 116 - T-MUTING	84
Fig 117 - X-MUTING	84
Fig 118 - Phase 1.....	85
Fig 119 - Phase 2.....	85
Fig 120 - Phase 3.....	85
Fig 121 - Connection box.....	86
Fig 122 - Dimensions	87
Fig 123 - SG-SRT-1	88
Fig 124 - SG-SRT-2	88
Fig 125 - SG-BWS-T4 Safety control unit	89
Fig 126 - SG-BWS-T4-MT Safety control unit.....	89



 **DATALOGIC**

www.datasensing.com