

ERMI200/60

The attraction and holding of the magnetic pieces are made by permanent magnets mounted in the solenoid. With these kind of products, we avoid the risk of load falling due to sudden power supply failure. The power supply on the coil allows to loose the load, when this power supply stops, the product recovers its initial force. When working with suspended loads, security norms must be respected.

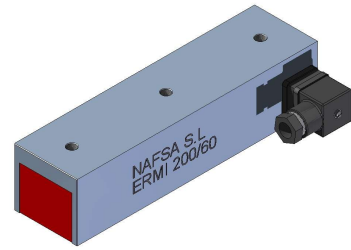

Protection rate: IP65
 Insulation class: Y (90°C)
 Standard voltage: 24VDC
 Standard power: 250W
 Standard duty-cycle: ED15%
 Solenoid weight: 4.7 kg

Supply possibilities:

- Connector standard
- **Alternating current connection (AC):**
 The connector offers the possibility of incorporating rectifying diodes
- Under demand: other possibilities of input can be manufactured.
- If any changes from the original (see drawing), please contact.

- Electric connection of the connector: see documentation that is enclosed with the material
- Earthing is recommended if the metallic parts are accessible.
- Technical explanations: see documents 1.4 & 1.5

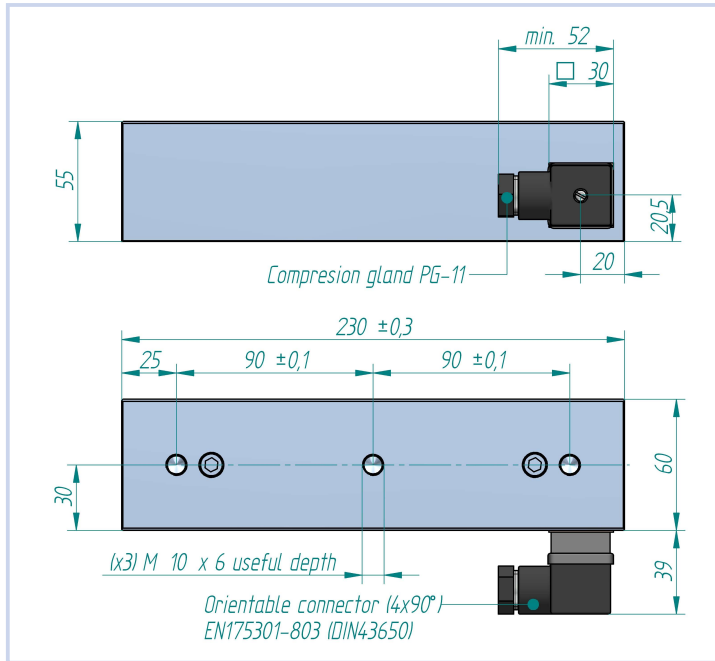

Table 1

Thickness of the piece to hold(mm)	Air gap (mm) δ_L							Magnetic Force Fm (N)
	0	0.1	0.2	0.3	0.4	0.5	1	
1	250	210	190	180	165	160	140	
3	1350	1250	1150	1100	1000	925	570	
6	2350	2000	1750	1400	1200	1100	590	
10	2800	2450	2150	1900	1600	1400	700	
18	3000	2550	2300	2000	1700	1500	800	

For these holding electromagnet correct working the minimum pulse and resting time must be respected:

- **Minimum pulse time: 300ms**
- **Minimum resting time: 5000ms**

The values of the minimum pulse time and resting time measured in the following conditions:

- Coil working on its regime temperature.
- Piece weight: 2 kilos (it is not recommended to use these holding electromagnet for lower weights)

The table 2 gives for each type of holding magnet, the values of the force of maintenance (Fm) based on the air gap, measured in the following conditions:

- Holding electromagnet without voltage.
- Flat piece (3μ m rugosity) in A°St37, thickness as shown in the table 2 and dimensions are similar or bigger than the attraction face.
- Room temperature 35°C.
- Coil working on its regime temperature.

At different conditions, the magnetic force(Fm) may decrease.The value of the magnetic remanence after the power supply stops is 5% of the holding force.



When lifting or handling heavy loads a minimum security margin of 3 must be respected, the weight of the load cannot exceed 33% of the magnetic force.

Ordering code:

Ref.: ERMI200/60 24Vdc ED15%