

ECI35/C TYPE

ECI serie electromagnets are bistable linear electromagnet, where the stroke movement from initial to final position is made by a incorporated spring.

When solenoid is in final position after been under voltage (See drawings bellow), the mechanical reset to the initial position has to be made by external forces acting on the mobile core.

The plunger is retened in the initial position by permanent magnets. To release the plunger is necessary feed the electromagnet with a low power polarized voltage signal.

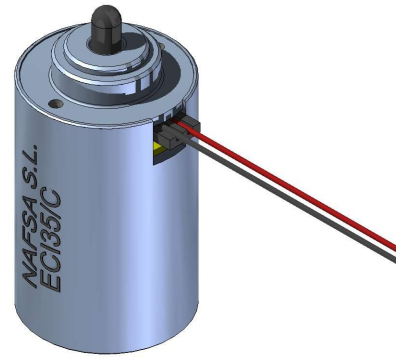

- Solenoid protection rate:** IP40
- Insulation class:** Y (90°C)
- Minimum release voltage:** 6V
- Duty-cycle ED:** 100%
- Standard stroke "s":** 8 mm
- Work:** Push
- Magnetic retention force (F_{rm}):** 44N
- Initial force (F_e):** 37N
- Useful magnetic force (F_{ru}=F_{rm}-F_e):** 7N
- Final force (F_a):** 18N
- Mechanical response time:** 5ms
- Minimum energy of release:** 30 mJ
- Minimum duration of the electrical impulse:** 20ms
- Solenoid weight:** 0.190 Kg

Force-stroke curve

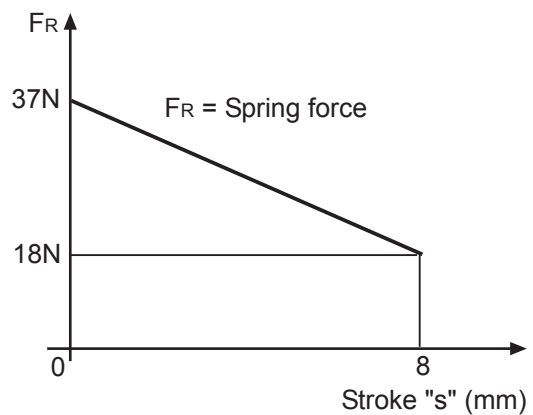

Solenoid with compressed spring

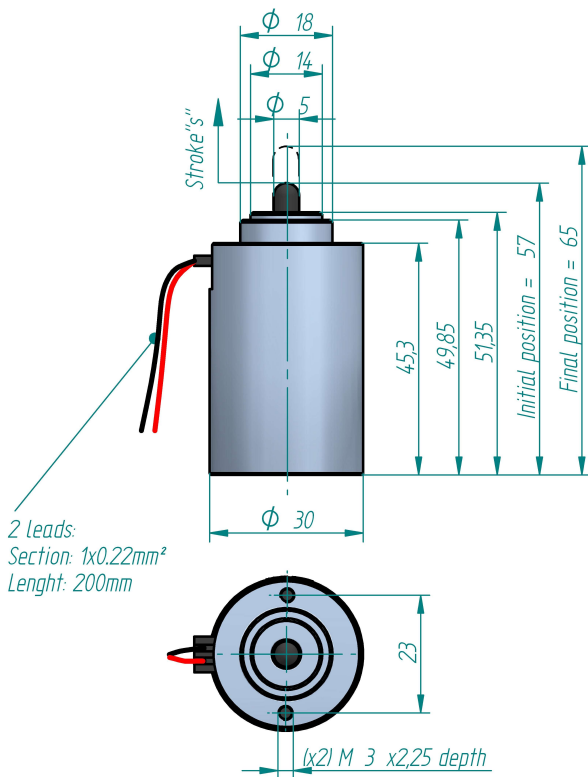

Working

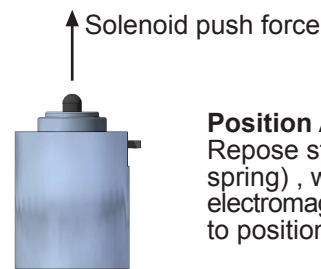

Position A (Initial position):
Repose status (compressed spring), when the electromagnet is feeded it pass to position B.

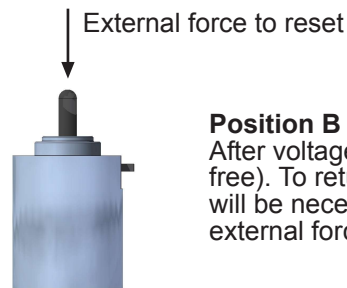

Position B (Final position):
After voltage status (spring free). To return to position A, will be necessary to apply an external force

Ordering code: ECI35/C 6Vdc ED100%