

## Technical data sheet

---

### Socket with built-in USB charger



---

#### Identification

---

Type ST-0029 250V 16A / 1 x USB-A / 1 x USB-C  
Part No. [810029](#)

---

#### Product version

---

Datasheet version 01

---

#### Use/Application/Properties

---

Description Schuko socket with integrated USB charger. One charging port USB-A (max. 2.4 A) and one charging port USB-C (max. 3.0 A) are available. A special charging technology recognises the charging protocol of the connected device and thus ensures fast and efficient charging. The Schuko socket outlet has mechanical protection against accidental contact (shutter).

---

#### Technical Data socket

---

Rated voltage  $U_N$  AC 250 V  
Rated current 16 A  
Connector type F (CEE 7/3)  
Contact durability 5000

---

#### Technical Data USB charger

---

Input voltage AC 220 – 250 V, 50 Hz  
Input current max. 0,5 A  
Output voltage DC 4.75 – 5.25 V  
Output current 0.01 – 3.0 A  
Power output 15 W  
Energy efficiency  $\geq 86\%$   
Heat dissipation (Standby consumption)  $\leq 70$  mW  
Connector type 1 x USB-A / 1 x USB-C  
Contact durability USB-A-Port: 5000  
USB-C-Port: 10000

---

#### Lütze Transportation GmbH

Postfach 12 24 (PLZ 71366) • Bruckwiesenstraße 17-19 • D-71384 Weinstadt  
Tel. +49 (0)7151 6053-545 • Fax +49 (0)7151 6053-6545  
[www.luetze-transportation.com](http://www.luetze-transportation.com) • [sales.transportation@luetze.de](mailto:sales.transportation@luetze.de)

29.03.2022 • Subject to technical modification

Part No. [810029](#) • Datasheet version: 01

page 1 of 5

## Technical data sheet

---

### Technical data

---

Connection type	Spring terminal single-wire 1.5 ... 2 × 2.5 mm <sup>2</sup> fine stranded 1,5 ... 2 × 2,5 mm <sup>2</sup> Stripping length: 11 mm
Operation temperature range	-25 °C ... +55 °C

---

### General

---

Dimensions (w × h × d)	71.0 mm × 71.0 mm × 44.0 mm
Weight/unit	0.095 kg
Color of the housing	anthracite, matte
Mounting	8 possible fixing points for screw or claw mounting (included in delivery).
Installation position	USB connectors on top Suitable for cover frames 55 × 55 mm (not in the scope of delivery) Installation depth: 32 mm Torx + Pin PIN-TX10 (anti-theft security screw)

---

### Environmental service conditions

---

<b>Altitude</b>	2000 m
Operating temperature class	OT1: -25 °C ... +55 °C
Switch-on extended Operating temperature class	ST1: OTx + 15 °C
Temperature variation class	H1:no requirements
Shock/Vibration	Category 1, class B
Class of supply voltage interruption	S2: 10 ms
Supply change-over class	C1: 100 ms
Useful life class	L4: 20 years
Degree of pollution	PD2
Over voltage category	OV2
Socket and edge connector	K2: Sockets for ICs and/or edge connectors are not used
Protective coating class	PC2: lacquered on both sides
Degree of protection	IP20

## Technical data sheet

---

### Standards/Certifications

---

Standards	<p><b>EN 50155:2021:</b> Railway applications – Rolling stock – Electronic equipment (testing according chapter 13.3 table 11)</p> <p><b>EN 50121-3-2:2016:</b> Railway applications – Electromagnetic compatibility – Part 3-2: Rolling stock – Apparatus</p> <p><b>Regelung EMV 06:2019:</b> Technische Regeln zur Elektromagnetischen Verträglichkeit – Nachweis der Funkverträglichkeit von Schienenfahrzeugen mit Bahnfunkdiensten</p> <p><b>EN 50124-1:2017:</b> Railway applications – Insulation coordination – Part 1: Basic requirements – Clearances and creepage distances for all electrical and electronic equipment</p> <p><b>EN 61373:1999:</b> Railway applications – Rolling stock equipment – Shock and vibration tests</p> <p><b>EN 61373:2010:</b> Railway applications – Rolling stock equipment – Shock and vibration tests</p> <p><b>EN 62368-1:2014+AC:2015:</b> Audio/video, information and communication technology equipment – Part 1: Safety requirements</p> <p><b>EN 45545-2:2020:</b> Railway applications – Fire protection on railway vehicles – Part 2: Requirements for fire behaviour of materials and components</p>
-----------	---

### Accessories

---

Accessories	Cover frame, anthracite matte, Type CF-0035, part number 810035
-------------	---

## Dimensions

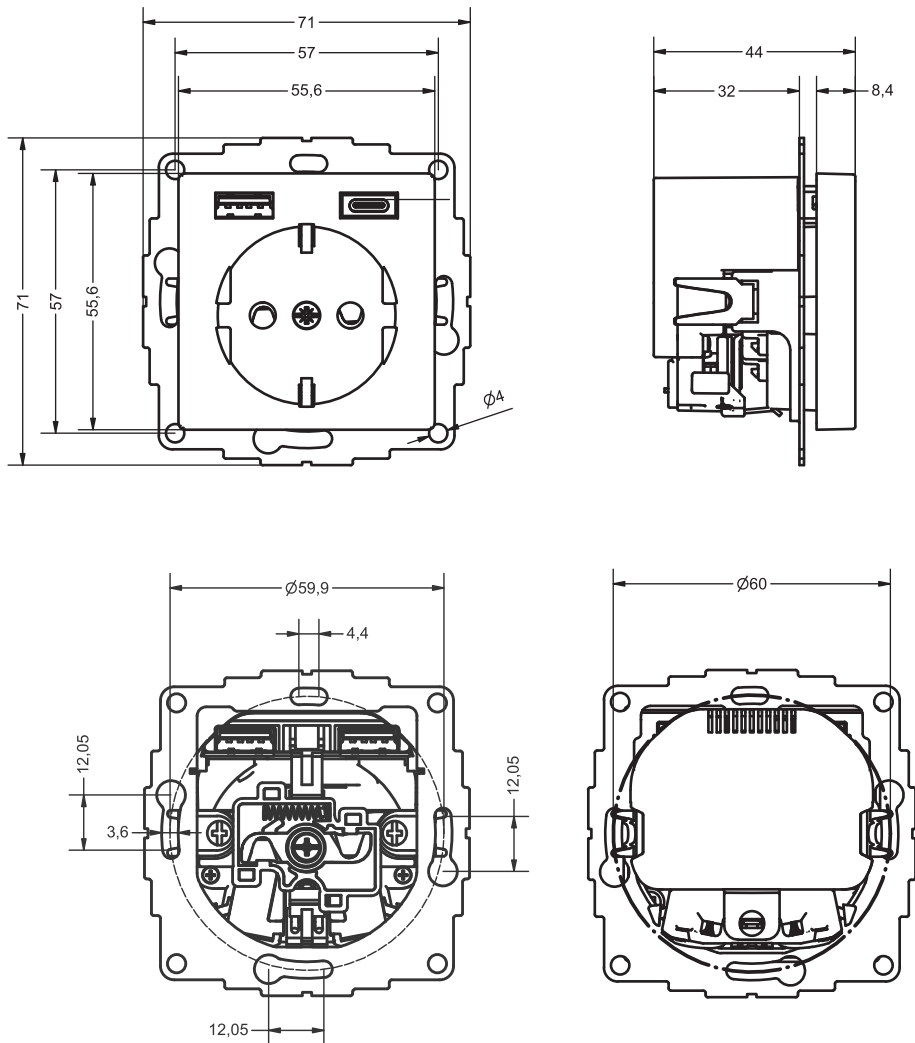

## Derating

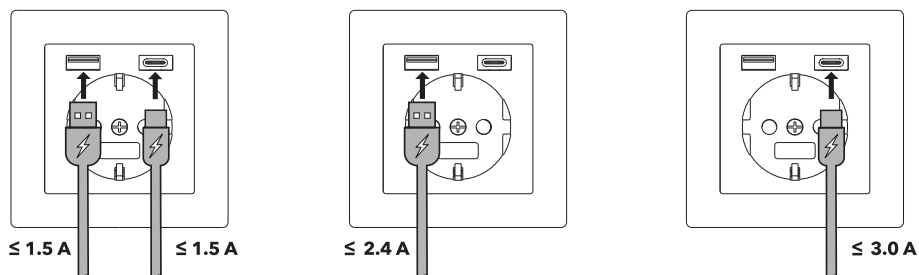

## Circuit diagram

