



■ Operation Instructions

DIOLINE20 Digital I/O Modules

Version 4.50

Lütze Transportation GmbH
Bruckwiesenstraße 17-19
D-71384 Weinstadt
Tel.: +49 (0) 7151 6053-545
Fax: +49 (0) 7151 6053-6454
Sales.Transportation@luetze.de
www.luetze-transportation.de



Content

1	Introduction	1
2	General Information	2
2.1	Symbol Description	2
2.2	Copyright	2
2.3	Disclaim of Liability	2
2.4	Related Documents	3
3	Safety	4
3.1	Content of the Manual	4
3.2	Intended Use	4
3.3	Recepients	4
3.4	Operating Employees	4
3.5	Responsibility of the Operator	4
3.6	Protective Clothing and Equipment	5
3.7	Reconstruction and Modifications of the Product	5
3.8	Safety Appliance	5
3.9	Special Safety Messages	5
4	Product Overview	6
4.1	Product Description	6
4.2	System Overview	7
4.3	Field of Application	8
5	Transport and Storing	9
6	Scope of Delivery	10
7	General Technical Data	11
8	Mounting	13
8.1	Mounting Options	13
9	Initial Operation – Hardware	14
9.1	Power Supply	14
9.2	L-Bus – Interface	15
10	Digital Inputs	17
10.1	Characteristics	17
10.2	2x8 Digital Inputs DC 24, 72, 110 V	18
10.2.1	Product Assembly	18
10.2.2	LED Display	19
10.2.3	Technical Data	20
10.2.4	Connecting the Digital Inputs	23
10.2.5	Operation	25
10.3	4x4 Digital Inputs DC 24 and 72 V	28
10.3.1	Product Assembly	28
10.3.2	LED Display	29
10.3.3	Technical Data	30
10.3.4	Connecting the Digital Inputs	32
10.3.5	Operation	34
11	Digital Outputs	36
11.1	Characteristics	36
11.2	2x8 Digital Outputs 24 V DC 2x8 Digital Outputs 24 V DC – redundancy capable	37
11.2.1	Product Assembly	37
11.2.2	LED Display	38

11.2.3	Technical Data	39
11.2.4	Connecting the Digital Outputs	41
11.2.5	Operation	43
11.3	4x2 Digital Outputs DC 24 V with Diagnosis	
	4x2 Digital Outputs DC 24 V with Diagnosis – redundancy capable	45
11.3.1	Product Assembly	45
11.3.2	LED Display	46
11.3.3	Technical Data	47
11.3.4	Connecting Digital Outputs	49
11.3.5	Diagnosis	51
11.3.6	Operation	52
11.4	6 Digital Outputs DC 110 V	
	6 Digital Outputs DC 110 V – redundancy capable	54
11.4.1	Product Assembly	54
11.5	LED Display	55
11.5.1	LEDs – L-Bus	55
11.5.2	LEDs – Output Signals	55
11.5.3	Technical Data	56
11.5.4	Connecting the Digital Outputs	58
11.5.5	Diagnosis	59
11.5.6	Operation	60
12	Digital Combination	62
12.1	Characteristics	62
12.2	2x4/2x4 Digital Combi Module DC 24 V	63
12.2.1	Product Assembly	63
12.2.2	LED Display	64
12.2.3	Technical Data	65
12.2.4	Connecting the Digital Outputs and Inputs	67
12.2.5	Operation	69
13	Relay Outputs	70
13.1	Characteristics	70
13.2	Lifetime	70
13.3	6 Relay Outputs	71
13.3.1	Product Assembly	71
13.3.2	LED Display	72
13.3.3	Technical Data	73
13.3.4	Connecting the Relay Outputs	74
13.3.5	Operation	76
14	Spacer	77
14.1	Characteristics	77
14.2	Product Assembly	78
14.2.1	LED Display	79
14.2.2	Technische Daten	80
15	Demounting	81
16	Final Shutdown and Disposal	82
17	Service	83
18	Appendix	84
18.1	Overview – DIOLINE 20 Identifier	84

1

Introduction

This manual is part of the Digital I/O Modules. It contains important information about the handling and safety. To avoid hazardous situations read the manual before installing the product and using it.

Store the manual at a handy place. If selling, renting or in case of a divestiture pass the manual to the authorize person.

2 General Information

2.1 Symbol Description

The manual contains several safety messages. Each safety message contains a defined signal word and a color. The color and the word are referring to an alert level. There are 4 levels. The safety messages point out hazardous situations and give information to avoid those.



Indicates a hazardous situation which, if not avoided will result in death or serious injury.



Indicates a hazardous situation which, if not avoided could result in death or serious injury.



Indicates a hazardous situation which, if not avoided could result in minor or moderate injury.



Is used to address practices not related to personal injury.

2.2 Copyright

This manual is intended for the operator and his staff. It is forbidden to give the content to a third party, to duplicate, exploit or impart it. The Lütze Transportation GmbH has to allow it explicit in writing.

General data, text, images and drawings are copyrighted and are liable to the industrial property right. Contravention can be prosecuting criminally. The named brands and product names in this document are trademarks or registered trademarks by titleholder.

2.3 Disclaim of Liability

The manual was written under consideration of the applied standards, regulations and the current state of technology.

The content is verified of accuracy. Discrepancies are not excluded. For those discrepancies we disclaim liability. Applicable changes and additional information will be in the next version of the manual.

The Lütze Transportation GmbH does not assume liability for any damages and accidents of following reasons:

- Nonobservance of the manual
- Untrained and unqualified employees
- Non conventional use
- Non approved reconstructions and functional modifications of the product
- Using non original or non admitted parts or equipment

2.4

Related Documents

The digital I/O modules are always operated with different PLCs and buscoupler.

NOTICE

Read the manual of the PLC or buscoupler before using the I/O modules.

3 Safety

3.1 Content of the Manual

Read and follow the manual before using the product the first time. This applies to every person which is getting in touch with the product. Trained employees and experts especially qualified persons which had worked with similar products before have to read and understand the manual.

3.2 Intended Use

The DIOLINE20 I/O modules are designed for the exclusive use in railway vehicles, as:

- In- and output for signals which are controlled by a busnode or a PLC

Use the I/O modules only for the listed cases and only with external devices recommended and allowed by Lütze Transportation GmbH.

The intended use involves also the use according to the operation instructions.

3.3 Receptients

The operating manual addresses planers, project manager and programmers. It also addresses the operating employees which are responsible for the initial operation, the operating and for the maintenance of the products and systems. Regarding the employees different qualification levels are differentiated.

3.4 Operating Employees



Risk of injury by deploying insufficient qualified operating employees.

Inappropriate appoint of not qualified or insufficient personal can cause property damages and personal injuries. Tasks which apply special procedures should be done by trained and qualified employees or experts, especially electricians.

Trained Employees

The employee was trained by the employer on the task and possible hazardous situations. The employee does not have any technical knowledge.

Experts

The employee has a technical education, knowledge and/or experience in the required field. The employee is capable to do specific operations on and with the product.

Electrically qualified persons

The employee has a technical education in the required field. The employee is capable to do special operations on and with the product.

The different sections of the manual referring to the qualification level of the operating employees.

3.5 Responsibility of the Operator

The operator is obligate by the law of occupational safety, if the product is used in a commercial field.

- The operator is responsible to train the employees and to inform himself about the industrial safety regulation.
- The operator is responsible that safety, environment protection regulations and rules for accident prevention are observed.
- The operator has to run a risk assessment at the working environment/place of installation to expose hazards and to alert those.
- The manual has to be stored near the product.
- The manual has to be obeyed.
- The product can just be run in a faultless technical condition.

3.6 Protective Clothing and Equipment

NOTICE

If working with or on the I/O Modules, wear special ESD clothing. Because static electrification can destroy parts of the buscoupler which can cause a malfunction of the whole product.

NOTICE

Follow the instructions and regulations of the employer.

3.7 Reconstruction and Modifications of the Product

WARNING

Reconstructions and modifications of the product can cause property damages or personal injuries. Do not reconstruct or modify the product if the manufacturer does not allow it explicit in writing.

3.8 Safety Appliance

CAUTION

Do not bypass protection equipment and safety arrangements. The product can be damaged by overvoltage and electric shocks are possible.

NOTICE

The I/O modules do not guarantee the safety of the whole process and/or the whole system.

3.9 Special Safety Messages

CAUTION

Use a nominal operating voltage of 24 Volts. The lower (16.8 Volts) and upper (30 Volts) threshold voltage is given in the technical data. A higher voltage can cause electric shocks and damage the product.

NOTICE

Dismount all electronic modules and their connections of the frame if intended to do some welding. The product can be damaged by compensating current.

4 Product Overview

4.1 Product Description

The DIOLINE20 I/O Modules are connected to a buscoupler or PLC via the L-Bus (Lütze Bus). The I/O Modules are available as:

Type

8 digital Inputs

8 digital Outputs

16 digital Inputs

16 digital Outputs

8 digital Inputs, 8 digital Outputs

4 analog Inputs

4 analog Outputs

4 analog Inputs multiplexed

4 analog Outputs multiplexed

6 analog Inputs

6 analog Outputs

2 analog Inputs, 2 analog Outputs

16 digital Inputs, 8 digital Outputs

4 analog Inputs, 4 analog Outputs

4 analog Inputs, 2- analog Outputs

Spacer (alle data bits are reset)

4.2

System Overview

The I/O modules can be integrated in the product line of the DIOLINE20 automating system as follows.

The DIOLINE product line contains modular components. A unit consists of a controller with an integrated CPU and an extension module. It is possible to connect max. 10 local I/O extension modules on the controller. The extension modules are connected over the L-Bus. The graphic shows the DIOLINE product after their intelligence. The first module is the most intelligent one. The last one is a module with the fewest intelligence.

DIORAIL PC 2
Vehicle Control Unit

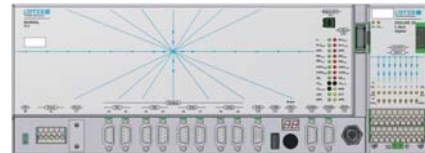

DIOLINE PLC
Compact Control Unit



DIOLINE20
Buscoupler Ethernet/ IP Adapter
Modular I/O Busnode



DIOLINE20
Buscoupler MVB Slave
Modular I/O Busnode

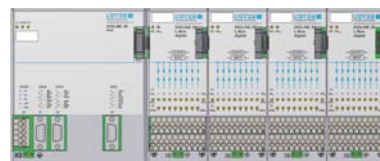

DIOLINE20
Buscoupler CANopen Slave
Modular I/O Busnode



DIOSWITCH
Unmanaged Ethernet Switch



4.3

Field of Application

The DIOLINE20 I/O Modules can be connected to buscoupler or PLCs.

5 Transport and Storing

NOTICE

Protect the product against humidity. Store the product in a dry room between -40 and 85°C.

NOTICE

Make sure that the I/O modules are safely packaged for transporting, to absorb possible crushes.

NOTICE

Dust can destroy electronic components. The circuit boards of the I/O modules are coated. But try to store and transport it in a dust free environment to avoid damages of the modules.

6 Scope of Delivery

- DIOLINE20 I/O Module
- Plug-in Connector
- Instruction Leaflet

7

General Technical Data

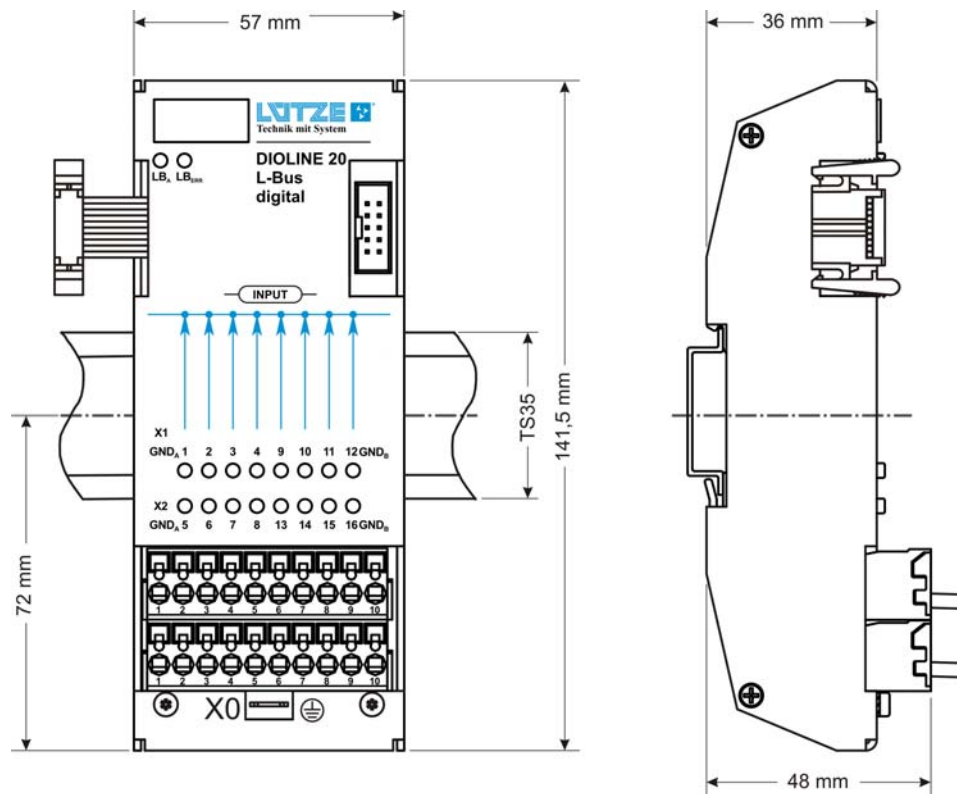
Mechanics

Dimensions (WxHxD)	57.0x141.5x48.0 mm
Housing	aluminum
Mounting	top hat rail

Electronic Module Supply

Voltage Supply	DC 16.8-30 V
Ripple	max. 10 %

Environmental Condition

Operating Temperature	-40°C to +70°C (+85°C for 10 min) according to EN 50155 class TX
Storage Temperature range min./max.	-40°C bis +85°C

Standards

EN 50155	Electronic equipment on railway vehicles
EN 50121	Electromagnetic compability
EN 50124	Insulation coordination
EN 61373	Vibration and shocks

NOTICE

For detailed standard information, please see the technical data sheet.

8 Mounting



CAUTION

Risk of injury by electric current. People can be injured by electric current and the product can be damaged. Deenergize the system before mounting.

NOTICE

Mount the product with a distance of 5 mm minimum to other products, to provide good air conditions.

1. Hook the module into the lower part of the top-hat rail.
2. Push the module a little bit up.
3. Push the module back that it catches the top-hat rail.

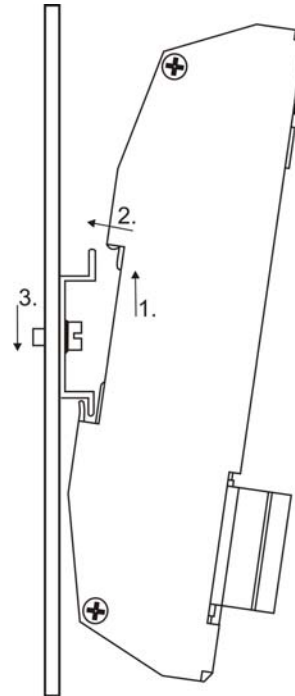

8.1 Mounting Options

The I/O modules can be mounted on a top-hat rail. Following mounting options are possible:

- horizontal
- vertical
- across

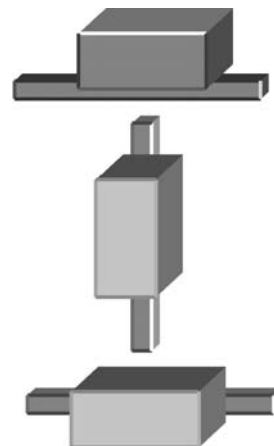

9 Initial Operation – Hardware

NOTICE

The initial operation has to be done by electricians.

To connect the modules correctly read the chapter of the required module. In the chapters you will also find information about the pin assignments.

9.1 Power Supply

The built in microcontroller of the digital I/O module is feeded by the L-Bus interface. The power supply has to be connected over the cage clamps of the modules. Read the required chapter. To ground the module connect the mounting tab X0.

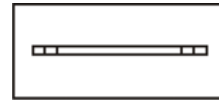

Fig. 1: Mounting Tab X0

9.2

L-Bus – Interface

The L-Bus interface is for coupling the local DIOLINE20 I/O modules. The L-Bus, (Lütze-Bus) is a special fieldbus invented by company Lütze.



Switch off the power when connecting or disconnecting the I/O modules.

If not observe, the whole system can be damaged. Hot Plugging is not supported by the system.

NOTICE

Connect max 10 I/O modules over the L-Bus interface. Mind the current consumption of the single modules. In the appendix *Seite 84* the according values are listed. A total current of max 1 A is possible on the L-Bus.

1. Switch off the power.

Pin	Signal	Description
1	24 V	Supply Voltage
2	24 V	Supply Voltage
3	GND	0 V Potential
4	/L_BUS_RESET	Module Reset
5	BUS_END	Identifier Bus End
6	OUT_OK	Data Confirmation
7	MDIN	Serial Input Data Master
8	SCK	Clock
9	SDOUT	Sending Serial Data
10	GND	0 V Potential

NOTICE

A change of the pin assignment is not possible, because of the predetermined connectors.

2. Connect the DIOLINE 20 I/O modules via the L-Bus Interface.

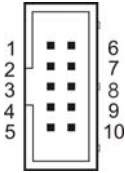

Fig. 2: L-Bus Master

3. Switch on the power.



Fig. 3: MVB Buscoupler with I/O Modules

4. The „LB“ LED is green.
The devices are ready for operation.



10.1**Characteristics**

- **Low-Pass Filter**
Disables errors which are smaller than the typical cycletime.
- **Insulation Channel**
Enables potential separation between the inputs and the system bus. And also between the inputs of the different groups.
- **Antiparallel Diode**
Avoids the damage of entry levels at the confusing of poles of the input and the ground.
- **Suppressor Diode and Input Varistor**
Surge protection, short-circuit-proof
- **Overcurrent Circuit**
Contact reliability of mechanic switching contacts
(fivefold input current for 7 ms minimum)

10.2 2x8 Digital Inputs DC 24, 72, 110 V

10.2.1 Product Assembly

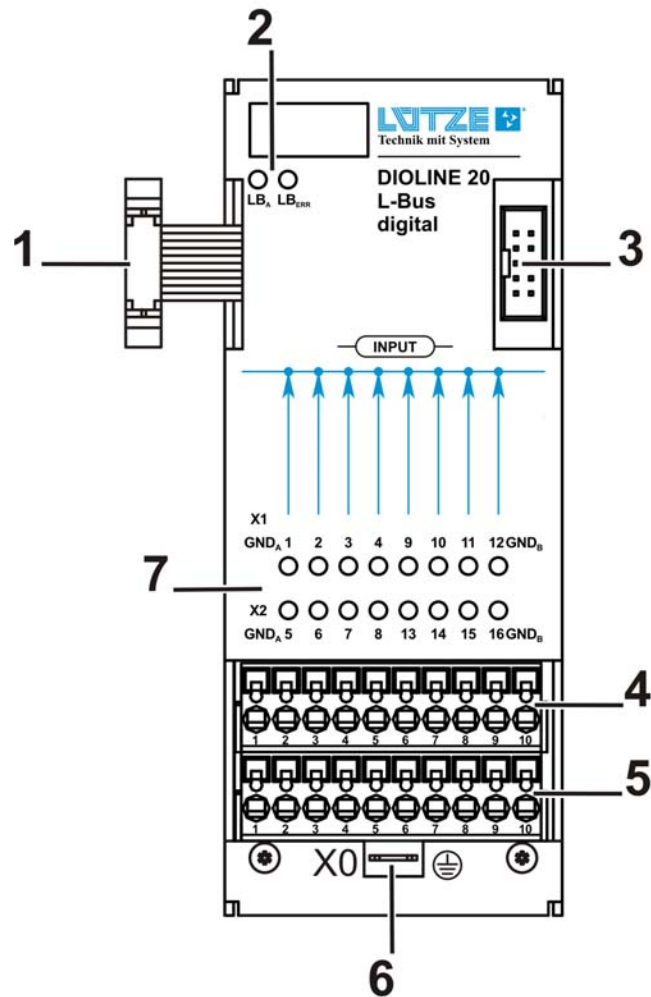

- 1 L-Bus Interface – incoming
- 2 LED Diagnosis Display – L-Bus
- 3 L-Bus Interface – outgoing
- 4 Connector Digital Inputs
- 5 Connector Digital Inputs
- 6 Neutral Conductor – Mounting Tab
- 7 LED Diagnosis Display – Digital Inputs

10.2.2 LED Display

10.2.2.1 LEDs – L-Bus



LED	Color	Status
LB _A	green	active
LB _{ERR}	red	Error

10.2.2.2 LEDs – Input Signals

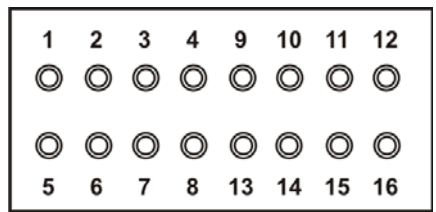

LED	Color	Status
1-16	yellow	Sensor active

10.2.3

Technical Data

Inputs 24 V Module

Number	16
Data Width in the Process Image	2 Byte Inputs
Current Consumption at DC 24 V	nom. 10 mA
Potential Insulation	Insulation Voltage <ul style="list-style-type: none"> ▪ AC 1.5 kV inputs and electronic ▪ AC 1.5 kV input potentials against each other
Input Voltage	“0” Signal: <ul style="list-style-type: none"> ▪ DC 0...6 V “1” Signal: <ul style="list-style-type: none"> ▪ DC 12.5...30 V
Input Current	“0” Signal: <ul style="list-style-type: none"> ▪ 0 mA 1 Signal at DC 24 V: <ul style="list-style-type: none"> ▪ min 25 mA for 7 ms when powering up, sloping to min. 4 mA “1” Signal Threshold: <ul style="list-style-type: none"> ▪ max. 50 mA at DC 30 V inrush current, min. 2 mA at DC 16.8 V constant current
Limit Threshold (thermic)	10 Hz at 50 % ED
Module Status Flag	The module status flag remains “0”. (“0” = no hardware error)

Inputs 72 V Module

Number	16
Data Width in the Process Image	2 Byte Inputs
Current Consumption at DC 24 V	nom. 10 mA
Potential Insulation	Insulation Voltage <ul style="list-style-type: none"> ▪ AC 1.5 kV inputs and electronic ▪ AC 1.5 kV input potentials against each other
Input Voltage	“0” Signal: <ul style="list-style-type: none"> ▪ 0...18 V DC “1” Signal: <ul style="list-style-type: none"> ▪ 36...90 V DC
Input Current	„0” Signal: <ul style="list-style-type: none"> ▪ 0 mA “1” Signal at DC 72 V: <ul style="list-style-type: none"> ▪ min. 8 mA for 7 ms when powering up, sloping to min. 2 mA “1” Signal Threshold: <ul style="list-style-type: none"> ▪ max. 15 mA at DC 90 V insrush current, min. 1 mA at DC 50.4 V constant current
Limit Threshold (thermic)	10 Hz at 50 % ED
Module Status Flag	The module status flag remains “0”. (“0” = no hardware error)

Inputs 110 V Module

Number	16
Data Width in the Process Image	2 Byte Inputs
Potential Insulation	Voltage Insulation <ul style="list-style-type: none"> ▪ AC 1.5 kV inputs and electronic ▪ AC 1.5 kV input potential against each other
Input Voltage	"0" Signal: <ul style="list-style-type: none"> ▪ DC 0...27.5 V "1" Signal: <ul style="list-style-type: none"> ▪ DC 55...137.5 V
Input Current	"0" Signal: <ul style="list-style-type: none"> ▪ 0 mA "1" Signal at DC 110 V: <ul style="list-style-type: none"> ▪ min. 5 mA for 7 ms when powering up, sloping to min. 1.2 mA "1" Signal Threshold: <ul style="list-style-type: none"> ▪ max. 9 mA at 137.5 V DC inrush current, min 0.7 mA at DC 77 V constant current
Limit Threshold (thermic)	10 Hz at 50 % ED
Module Status Flag	The module status flag remains "0" ("0" = no hardware error)

10.2.4

Connecting the Digital Inputs

Connect the digital inputs via the cage clamps X1 and X2. Follow these steps:

1. Switch off the power.
2. Connect the inputs regarding the pin assignment and the signals.

Digitale Inputs 24, 72 and 110 V (2 Potentials)

Cage Clamp X1

Pin	Signal	Description
1	GND _A	0 V - Potential A
2	DI1	Input 1 (1. Byte LSB)
3	DI 2	Input 2
4	DI 3	Input 3
5	DI 4	Input 4
6	DI 9	Input 9 (2nd Byte LSB)
7	DI10	Input 10
8	DI11	Input 11
9	DI12	Input 12
10	GND _B	0 V - Potential B

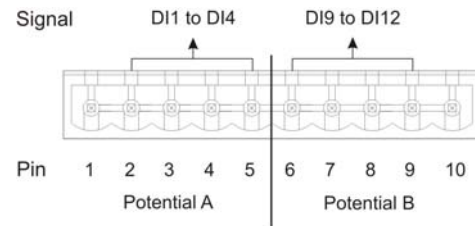

Coding

Module	Plug Connectors	Cage Clamp
24 V	Pin 2	Pin 3 and 4
72 V	Pin 4 and 7	Pin 2, 3, 5 and 6
110 V	Pin 4 and 6	Pin 2, 3, 5 and 7

Cage Clamp X2

Pin	Signal	Description
1	GND _A	0 V - Potential A
2	DI 5	Input 5
3	DI 6	Input 6
4	DI 7	Input 7
5	DI 8	Input 8 (1st Byte MSB)
6	DI13	Input 13
7	DI14	Input 14
8	DI15	Input 15
9	DI16	Input 16 (2nd Byte MSB)
10	GND _B	0 V - Potential B

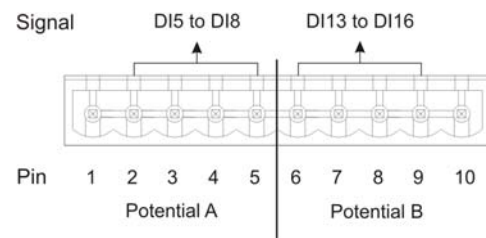

Coding

Modul	Plug Connectors	Cage Clamp Connectors
24 V	Pin 3	Pin 2 and 4
72 V	Pin 5 and 7	Pin 2, 3, 4 and 6
110 V	Pin 5 and 6	Pin 2, 3, 4 and 7

10.2.5 Operation

10.2.5.1 Block Diagram 2x8 Digital Inputs 24 V

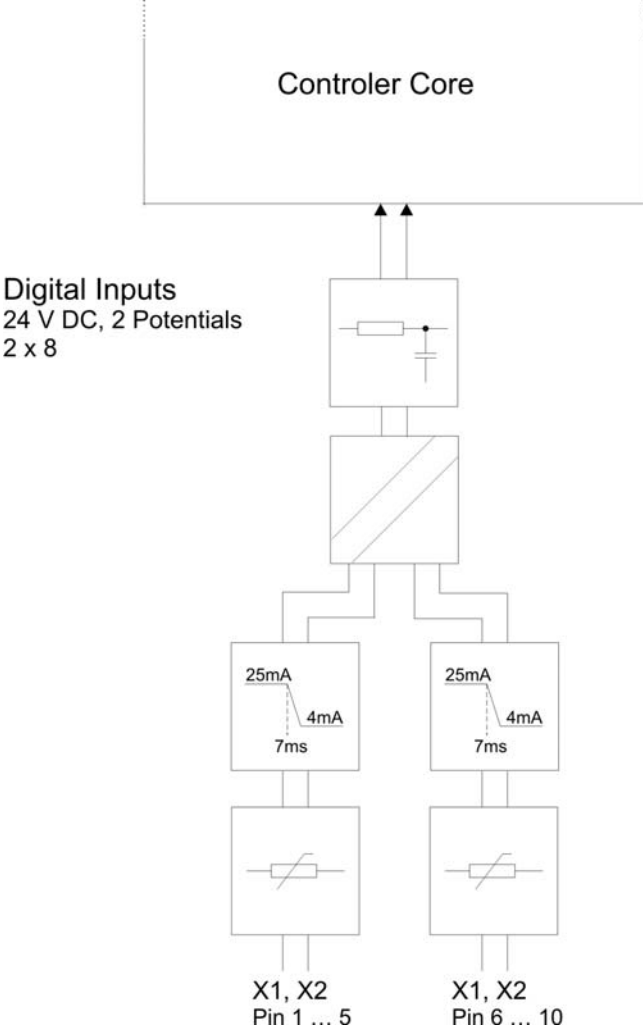

10.2.5.2 Block Diagram 2x8 Digital Inputs 72 V

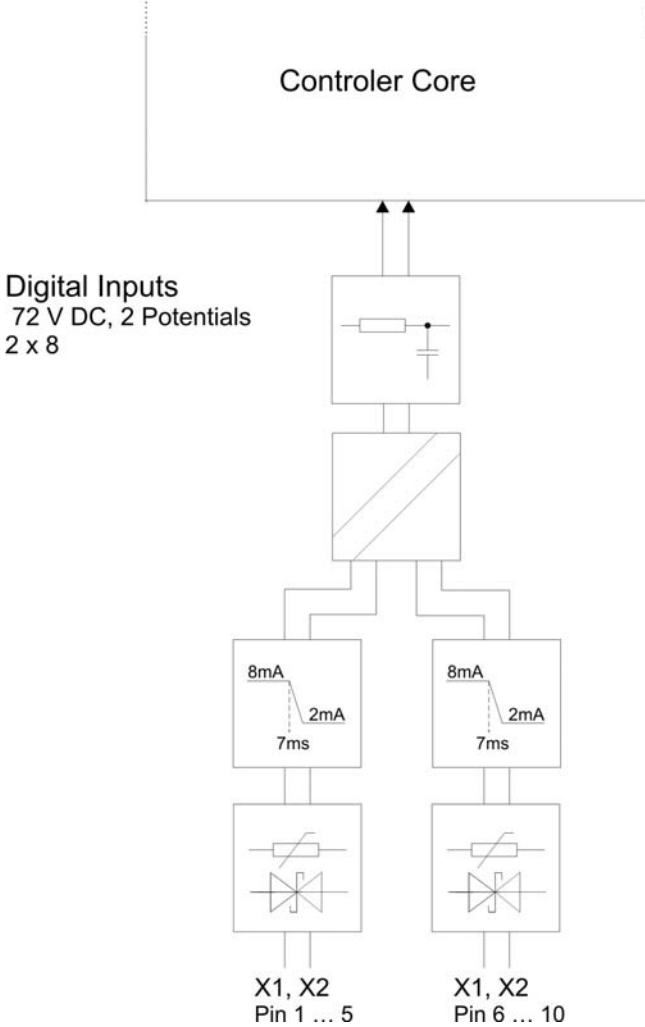

10.2.5.3 Block Diagram 2x8 Digital Inputs 110 V

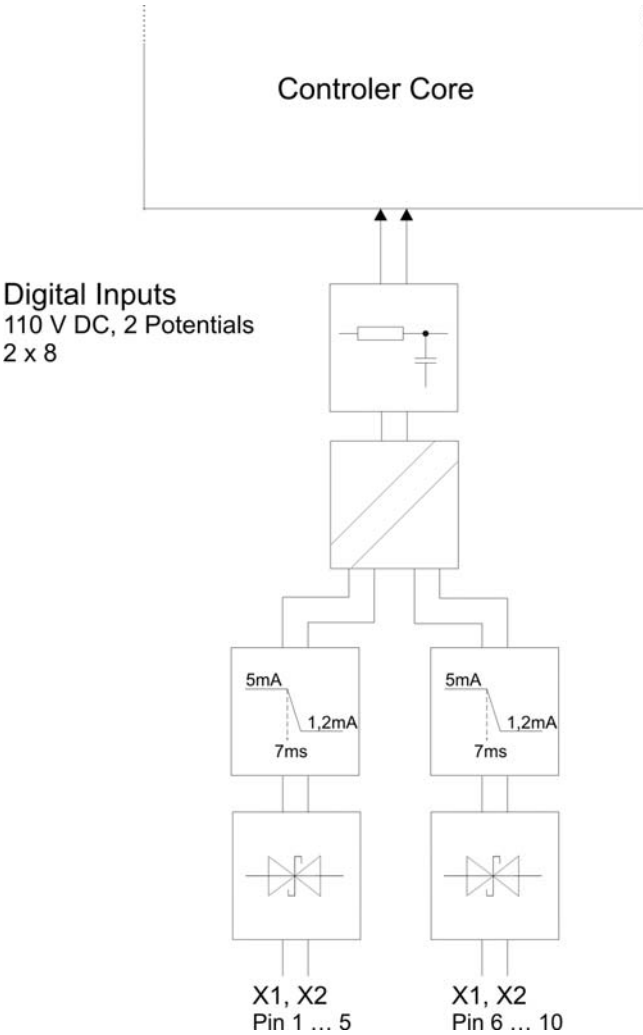

10.3 4x4 Digital Inputs DC 24 and 72 V

10.3.1 Product Assembly

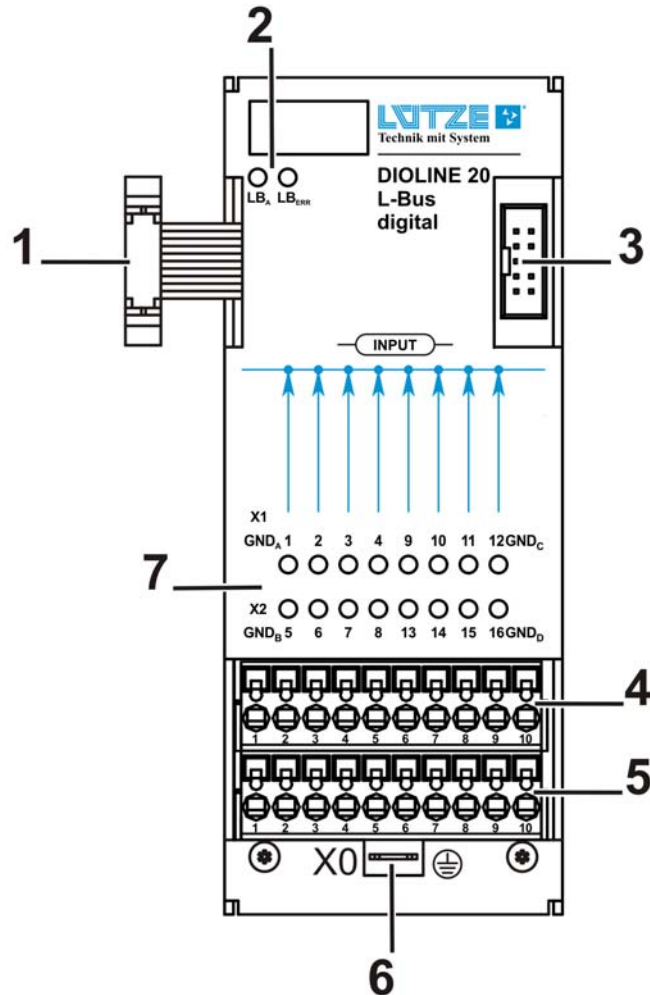

- 1 L-Bus Interface – outgoing
- 2 LED Diagnosis Display – L-Bus
- 3 L-Bus Interface – incoming
- 4 Connector Digital Inputs
- 5 Connector Digital Inputs
- 6 Neutral Conductor – Mounting Tab
- 7 LED Diagnosis Display – Digital Inputs

10.3.2 LED Display

10.3.2.1 LEDs – L-Bus



LED	Color	Status
LB_A	green	active
LB_{ERR}	red	Error

10.3.2.2 LEDs – Input Signals

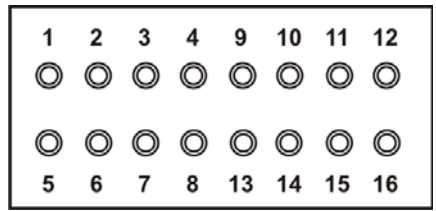

LED	Color	Status
1-16	yellow	Sensor active

10.3.3

Technical Data

Inputs 24 V Module

Number	16
Data Width in the Process Image	2 Byte Inputs
Current Consumption at 24 V DC	nom. 10 mA
Potential Insulation	Insulation Voltage <ul style="list-style-type: none"> ▪ AC 1.5 kV inputs and electronic ▪ AC 1.5 kV between potential A, B, C and D
Input Voltage	“0” Signal: <ul style="list-style-type: none"> ▪ DC 0...6 V “1” Signal: <ul style="list-style-type: none"> ▪ DC 12.5...30 V
Input Current	“0” Signal: <ul style="list-style-type: none"> ▪ 0 mA 1 Signal at DC 24 V: <ul style="list-style-type: none"> ▪ min 25 mA for 7 ms when powering up, sloping to min. 4 mA “1” Signal Threshold: <ul style="list-style-type: none"> ▪ max. 50 mA at DC 30 V inrush current, min 2 mA at DC 16.8 V constant current
Limit Threshold (thermic)	10 Hz at 50 % ED
Module Status Flag	The module status flag remains “0”. (“0” = no hardware error)

Input 72 V Module

Number	16
Data Width in the Process Image	2 Byte Inputs
Current Consumption at 24 V DC	nom. 10 mA
Potential Insulation	Voltage Insulation <ul style="list-style-type: none"> ▪ AC 1.5 kV inputs and electronic ▪ AC 1.5 kV between potential A, B, C and D
Input Voltage	“0” Signal: <ul style="list-style-type: none"> ▪ DC 0...18 V “1” Signal: <ul style="list-style-type: none"> ▪ DC 36...90 V
Input Current	“0” Signal: <ul style="list-style-type: none"> ▪ 0 mA 1 Signal at DC 72 V: <ul style="list-style-type: none"> ▪ min. 8 mA for 7 ms when powering up, sloping to min. 2 mA „1“ Signal Threshold: <ul style="list-style-type: none"> ▪ max. 15 mA at DC 90 V inrush current, min 1 mA at DC 50.4 V constant current
Limit Threshold (thermic)	10 Hz at 50 % ED
Module Status Flag	The module status flag remains “0”. (“0” = no hardware error)

10.3.4 Connecting the Digital Inputs

Connect the digital inputs via the cage clamps X1 and X2. Proceed as follows:

1. Switch off the power.
2. Connect the inputs regarding the pin assignment and the signals.

Digital Inputs 24 and 72 V (4 Potentials)

Cage Clamp X1

Pin	Signal	Description
1	GND _A	0 V - Potential A
2	DI1	Input 1 (1st Byte LSB)
3	DI 2	Input 2
4	DI 3	Input 3
5	DI 4	Input 4
6	DI 9	Input 9 (2nd Byte LSB)
7	DI10	Input 10
8	DI11	Input 11
9	DI12	Input 12
10	GND _B	0 V - Potential B

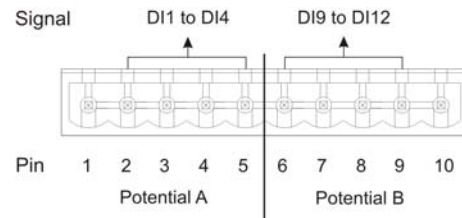

Coding

Module	Plug Connector	Cage Clamp
24 V	Pin 2	Pin 3 and 4
72 V	Pin 4 and 7	Pin 2, 3, 5 and 6

Cage Clamp X2

Pin	Signal	Description
1	GND _A	0 V - Potential A
2	DI 5	Input 5
3	DI 6	Input 6
4	DI 7	Input 7
5	DI 8	Input 8 (1st Byte MSB)
6	DI13	Input 13
7	DI14	Input 14
8	DI15	Input 15
9	DI16	Input 16 (2nd Byte MSB)
10	GND _B	0 V - Potential B

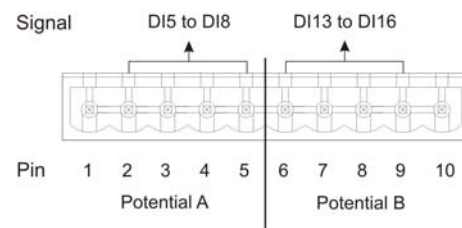

Coding

Modul	Plug Connector	Cage Clamp
24 V	Pin 3	Pin 2 and 4
72 V	Pin 5 and 7	Pin 2, 3, 4 and 6

10.3.5 Operation

10.3.5.1 BLock Diagram 4x4 Digital Inputs 24 V

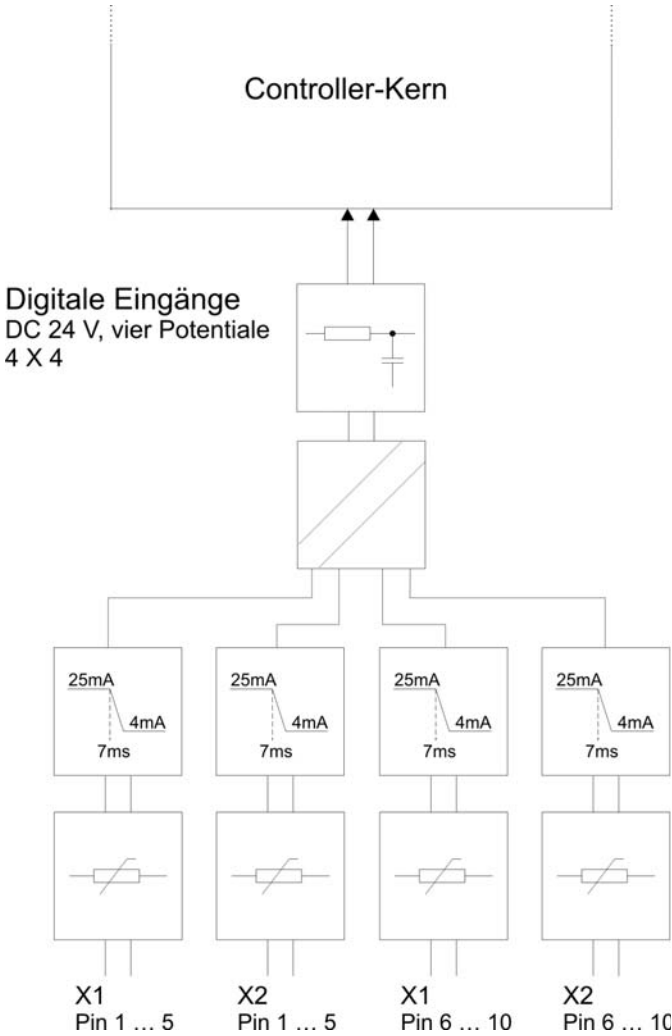

10.3.5.2 Block Diagram 4x4 Digital Inputs 72 V

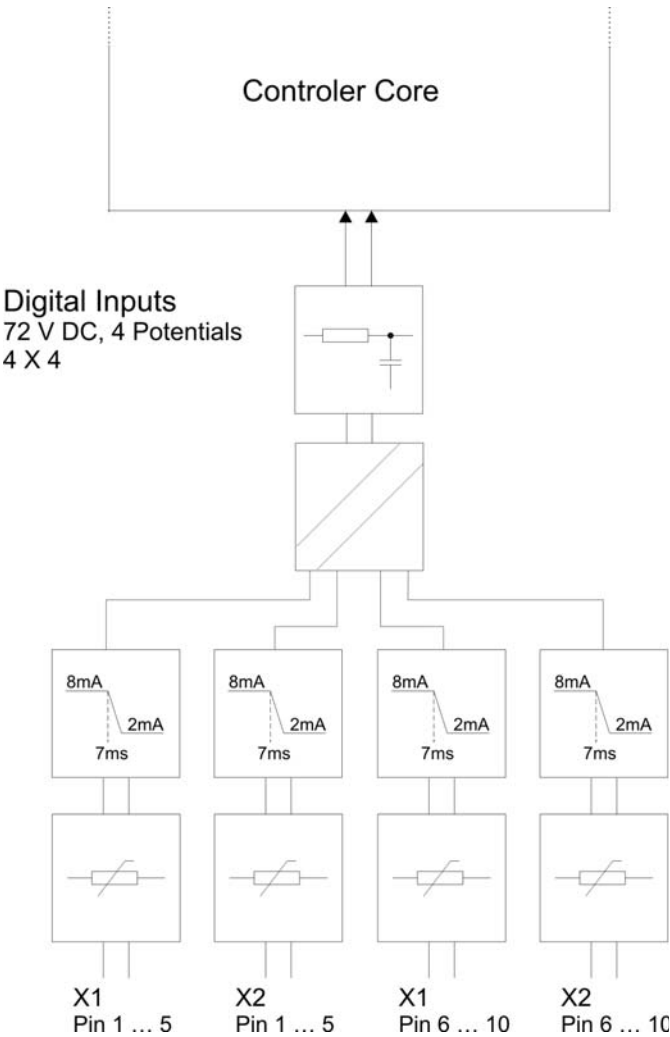

11.1

Characteristics

- Low-Pass Filter
Disables errors which are smaller than the typical cycletime.
- Insulation Channel
Enables potential separation between the inputs and the system bus. And also between the inputs of the different groups.
- Suppressor Diode
Surge protection
- Short-Circuit-Proofed
- Temperatur sensor
Avoids overcharging of the outputs
- Schottky Diode (only redundant outputs)
 - Module 2x8 DC 24 V redundant
On the output channels DO1-DO4 and DO9-DO12 it is possible to interconnect 2 channels to redundant outputs.
 - Module 4x2 DO redundant with Diagnosis DC 24 V
On the outputs it is possible to interconnect 2 channels to redundant outputs

11.2 2x8 Digital Outputs 24 V DC
2x8 Digital Outputs 24 V DC – redundancy capable

11.2.1 Product Assembly

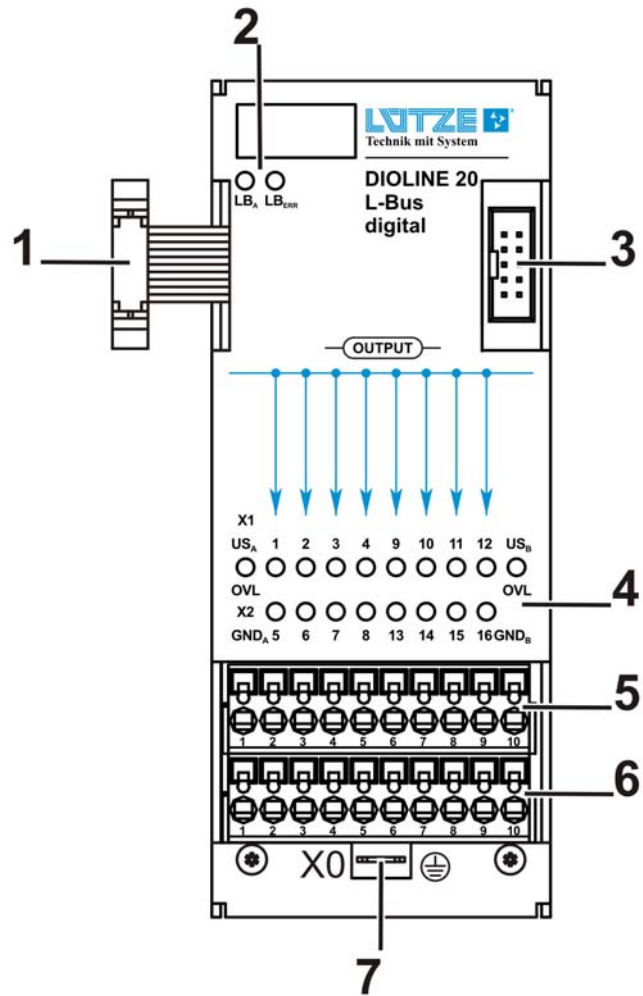

- | | |
|---|--|
| 1 | L-Bus Interface – incoming |
| 2 | LED Diagnosis Display – L-Bus |
| 3 | L-Bus Interface – outgoing |
| 4 | LED Diagnosis Display – Digital Inputs |
| 5 | Connector Digital Outputs |
| 6 | Connector Digital Outputs |
| 7 | Neutral Conductor – Mounting Tab |

11.2.2 LED Display

11.2.2.1 LEDs – L-Bus



LED	Color	Status
LB_A	green	active
LB_{ERR}	red	Error

11.2.2.2 LEDs – Output Signals

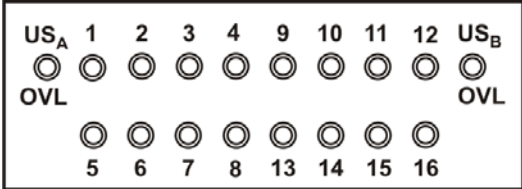

LED	Color	Status
1-16	yellow	Sensor active
US_A	green red	Supply OK Overload
US_B	green red	Supply OK Overload

11.2.3

Technical Data

Outputs for 24 V Moduls

Number	16
Data Width in the Process Image	2 Byte Inputs
Current Consumption at DC 24 V	nom. 10 mA
Potential Insulation	Voltage Insulation <ul style="list-style-type: none"> ▪ AC 1.5 kV inputs and electronic ▪ AC 1.5 kV input potential A to B
Output Current	<p>Enviromental Temperature < 50°C:</p> <ul style="list-style-type: none"> ▪ 2 A per channel, 8 A per group A/B <p>Enviromental Temperature > 50°C:</p> <ul style="list-style-type: none"> ▪ 1.25 A per channel, 5 A per group A/B <p>Idle Current Consumption 6.5 mA per group</p>
Limit Threshold (thermic)	10 Hz at 50 % ED
Safety Function	inverse, short-circuit proof, abnormal temperature protection
Channel type	N-MOS FET
Module Status Flag	In the error status of the output driver, the module status flag is set to "1".
Recommended Error Reaction	Turn off the affected output, and check the periphery connection

Outputs 24 V Module redundancy capable

Number	16 thereof 8 capable of redundancy
Data width in the process image	2 Byte Outputs
Current Consumption at DC 24 V	nom. 10 mA
Potential Insulation	Insulation Voltage <ul style="list-style-type: none"> ▪ AC 1.5 kV Outputs and Electronic ▪ AC 1.5 kV Potential A, to B
Output Current	Enviromental temperature < 50°C <ul style="list-style-type: none"> ▪ 2 A per channel, 8 A per group A/B Enviromental temperature >50°C <ul style="list-style-type: none"> ▪ 1.25 A per channel, 5 A per group A/B ▪ Closed Current 6.5 mA per group
Limit Threshold (thermic)	10 Hz at 50 % ED
Safety Function	inverse-polarity protection, short-circuit proof, abnormal temperature protection
Channel Type	N-MOS FET
Module Status Flag	In the error status of the output driver, the module status flag is set to "1".
Recommended Error Reaction	Turn off the affected output, and check the periphery connection
External Fuse	B10

11.2.4

Connecting the Digital Outputs

Connect the digital outputs via the cage clamps X1 and X2. Follow these steps:

1. Switch off the power.
2. Connect the outputs regarding the pin assignment and the signals.

Digital Outputs 24 V (redundant compatible)

Cage Clamp X1

Pin	Signal	Description
1	US _A	24 V DC - Potential A
2	DO 1	Output 1 (1st Byte LSB)
3	DO 2	Output 2
4	DO 3	Output 3
5	DO 4	Output 4
6	DO 9	Output 9 (2nd Byte LSB)
7	DO10	Output 10
8	DO11	Output 11
9	DO 12	Output 12
10	US _B	24 V DC - Potential B

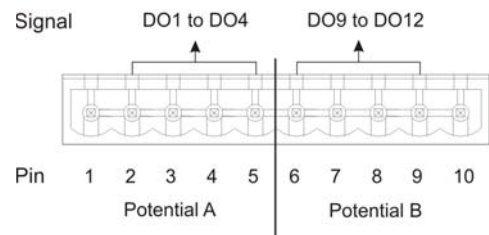

All outputs have a redundant diode.

Coding

Module	Plug Connector	Cage Clamp
24 V	Pin 2	Pin 3 and 4
24 V red.	Pin 2	Pin 3 and 4

Cage Clamp X2

Pin	Signal	Description
1	GND _A	0 V - Potential A
2	DO 5	Output 5
3	DO 6	Output 6
4	DO 7	Output 7
5	DO 8	Output 8 (1st Byte MSB)
6	DO 13	Output 13
7	DO 14	Output 14
8	DO 15	Output 15
9	DO 16	Output 16 (2nd Byte MSB)
10	GND _B	0 V - Potential B

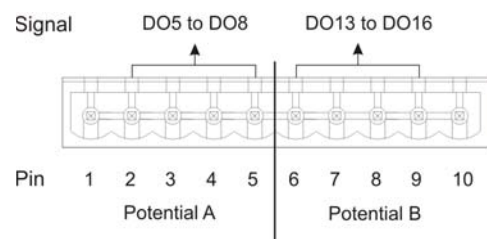

Coding

Module	Plug Connector	Cage Clamp
24 V	Pin 3	Pin 2 and 4
24 V red.	Pin 3	Pin 2 and 4

11.2.5 Operation

11.2.5.1 Block Diagram 2x8 Digital Outputs 24 V

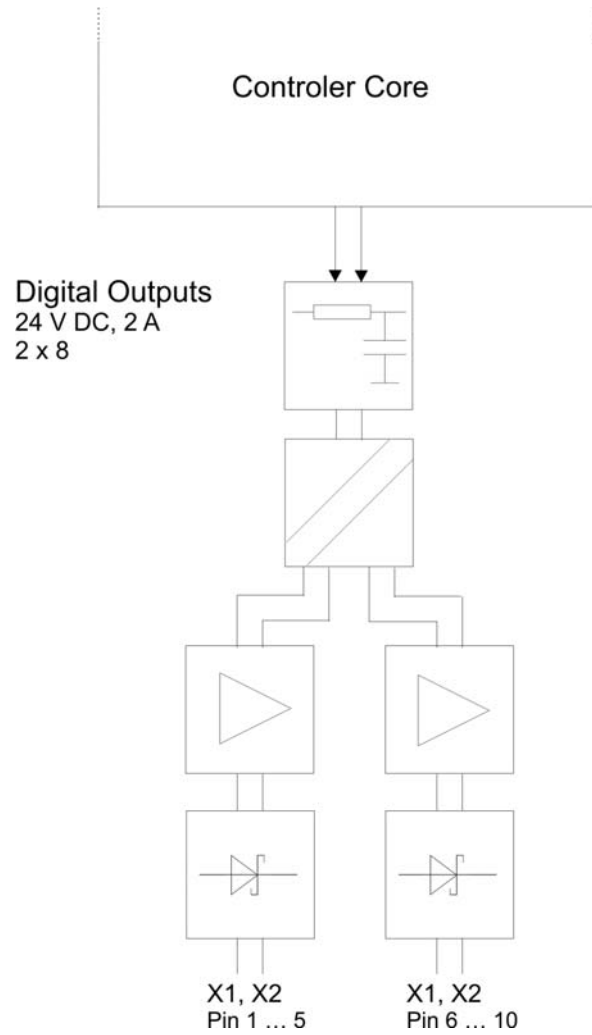

11.2.5.2 Block Diagram 2x8 Digital Outputs 24 V redundancy capable

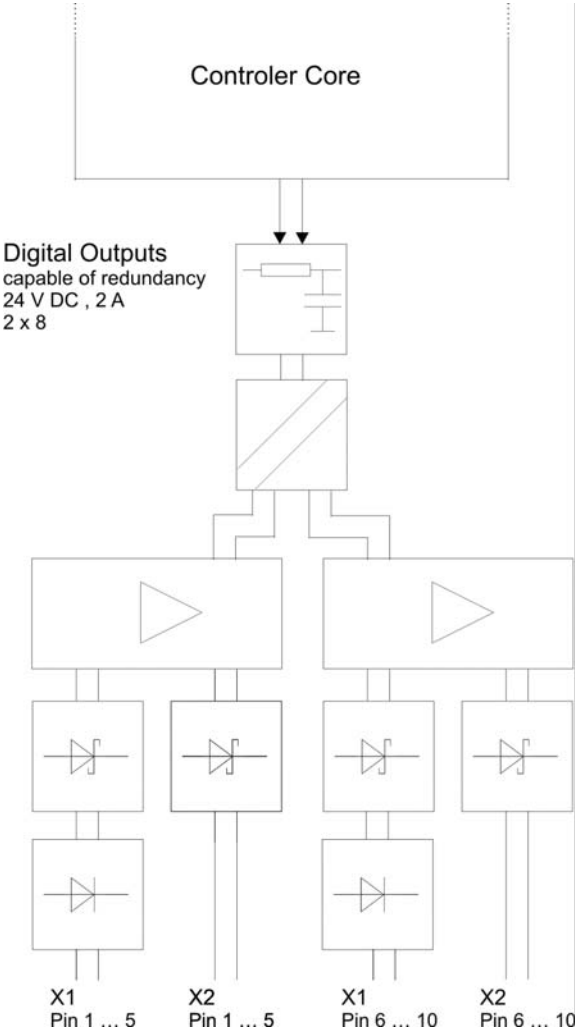

11.3 4x2 Digital Outputs DC 24 V with Diagnosis
4x2 Digital Outputs DC 24 V with Diagnosis –
redundancy capable

11.3.1 Product Assembly

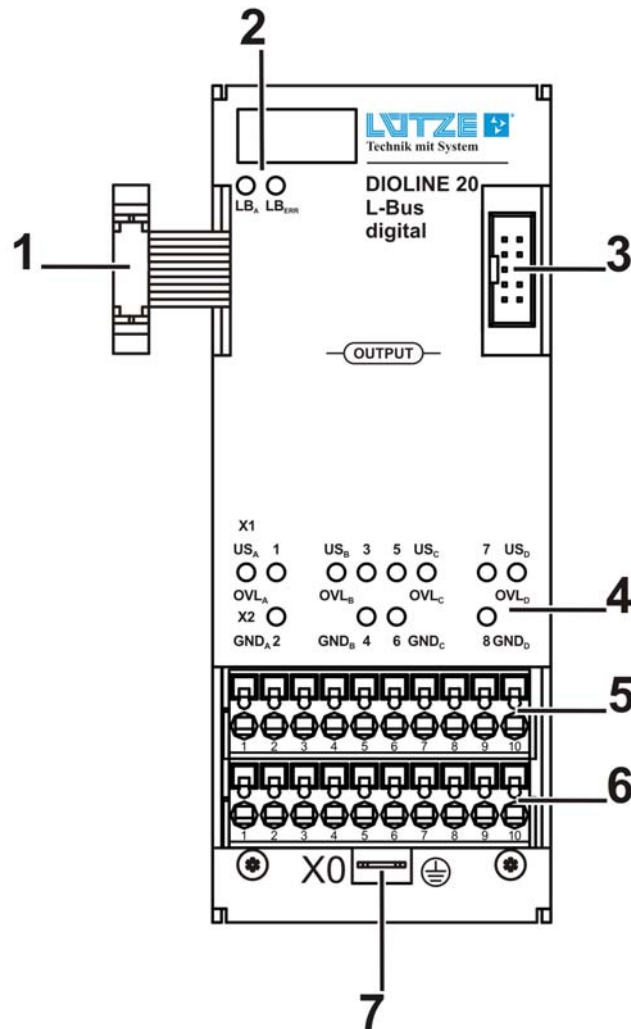

- 1 L-Bus Interface – incoming
- 2 LED Diagnosis Display – L-Bus
- 3 L-Bus Interface – outgoing
- 4 LED Diagnosis Display – Digital Outputs
- 5 Connector Digital Outputs
- 6 Connector Digital Outputs
- 7 Neutral Conductor – Mounting Tab

11.3.2 LED Display

11.3.2.1 LEDs – L-Bus



LED	Color	Status
LB_A	green	active
LB_{ERR}	red	Error

11.3.2.2 LEDs – Input Signals

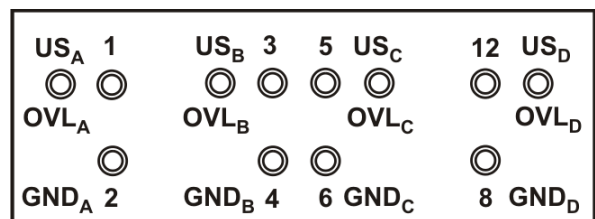

LED	Color	Status
1-8	yellow	Actor active
US_A	green	Supply OK
	red	Overload
US_B	green	Supply OK
	red	Overload
US_C	green	Supply OK
	red	Overload
US_D	green	Supply OK
	red	Overload

11.3.3

Technical Data

Outputs 24 V Module

Number	8
Data width in the process image	1 Byte Output 2 Byte Input Byte 1 = Read-back outputs Byte 2 = Status of the output driver
Current Consumption DC 24 V	nom. 10 mA
Potential Insulation	Voltage Insulation <ul style="list-style-type: none"> ▪ AC 1.5 kV outputs and electronic ▪ AC 1.0 kV between the output groups
Output Current	<ul style="list-style-type: none"> ▪ max. 3 A per channel ▪ max. 4 A per potential group ▪ max. 16 A per module <p>At a max load of 4 A on at least one channel following fragmentation results: (max. 12 A per module):</p> <p>Output: 1 2 3 4 5 6 7 8 Max load: 0A 2A 4A 0A 0A 4A 2A 0A</p>
Safety Function	inverse-polarity protection, short-circuit proof, abnormal temperature protection
Channel Type	N-MOS FET
Standby Current	max. 5 mA per group
Module Status Flag	Error status of the output driver is entered in the status byte (a bit for each output). The module status flag remains "0". ("0" = no hardware error)
Recommended Error Reaction	Turn off the affected output, and check the periphery connection
External Fuse	B6

**Outputs 24 V Module
redundancy capable**

Number	8 redundancy capable
Data width in the process image	1 Byte Outputs
Current Consumption at DC 24 V	nom. 10 mA
Potential Insulation	Voltage Insulation <ul style="list-style-type: none"> ▪ AC 1.5 kV outputs and electronic ▪ AC 1.0 kV between the output groups
Output Current	<ul style="list-style-type: none"> ▪ max. 2 A per channel ▪ max. 3 A per potential group ▪ max. 12 A per module Power consumption <ul style="list-style-type: none"> ▪ max. 5 mA per group
Safety Function	inverse-polarity protection, short-circuit proof, abnormal temperature protection
Channel Type	N-MOS FET
Module Status Flag	Error status of the output driver is entered in the status byte (one bit for each output). The module status flag remains "0". ("0"= no hardware error)
Recommended Error Reaction	Turn off the affected output, and carry out a thorough check of the periphery connection.
External Fuse	B6

All Outputs have a redundance diode.

11.3.4 Connecting Digital Outputs

Connect the digital outputs via the cage clamps X1 and X2. Proceed as follows:

1. Switch off the power.
2. Connect the outputs regarding the pin assignment and the signals.

Digital Outputs 24 V (capable of redundancy) – Diagnosis

Cage Clamp X1

Pin	Signal	Description
1	US _A	DC 24 V - Potential A
2	DO 1	Output1 (1st Byte LSB)
3	NC	Not connected
4	US _B	DC 24 V - Potential B
5	DO 3	Output 3
6	DO 5	Output 5
7	US _C	DC 24 V -Potential C
8	NC	Not connected
9	DO 7	Output 7
10	US _D	DC 24 V - Potential D

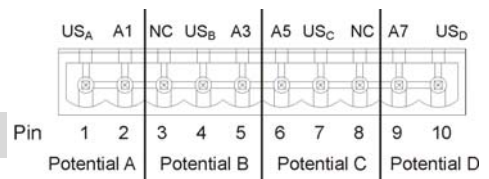

Coding

Module	Plug Connector	Cage Clamp
24 V	Pin 2	Pin 3 and 4
24 V red.	Pin 2	Pin 3 and 4

Cage Clamp X2

Pin	Signal	Description
1	GND _A	0 V - Potential A
2	DO 2	Output 2
3	NC	Not connected
4	GND _B	0 V - Potential B
5	DO 4	Output 4
6	DO 6	Output 6
7	GND _C	0 V - Potential C
8	NC	Not connected
9	DO 8	Output 8 (1st Byte MSB)
10	GND _D	0 V - Potential D

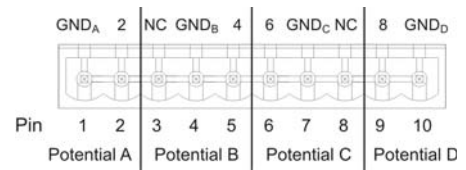

Coding

Module	Plug Connector	Cage Clamp
24 V	Pin 3	Pin 2 and 4
24 V red.	Pin 3	Pin 2 and 4

11.3.5

Diagnosis

The error status of the output driver is entered in the status byte. For every output one byte is entered. The module status flags stays "0".

There is no Hardware error if the output is 0. If the output is "1" there is an overload on the output channel.

Byte 1 (Read-back Bytes)

Bit 7	Bit 6	Bit 5	Bit 4	Bit 3	Bit 2	Bit 1	Bit 0
Switching Status (actual) Output Channel DO 8	Switching Status (actual) Output Channel DO 7	Switching Status (actual) Output Channel DO 6	Switching Status (actual) Output Channel DO 5	Switching Status (actual) Output Channel DO 4	Switching Status (actual) Output Channel DO 3	Switching Status (actual) Output Channel DO 2	Switching Status (actual) Output Channel DO 1

Bit i = 0: Switching status of the output channel DOx is off.

Bit i = 1: Switching status of the input channel DOx is on.

Byte 2 (Status of the Output Driver)

Bit 7	Bit 6	Bit 5	Bit 4	Bit 3	Bit 2	Bit 1	Bit 0
Status Output Driver Channel DO 8	Status Output Driver Channel DO 7	Status Output Driver Channel DO 6	Status Output Driver Channel DO 5	Status Output Driver Channel DO 4	Status Output Driver Channel DO 3	Status Output Driver Channel DO 2	Status Output Driver Channel DO 1

Bit i = 0: No error at the driver of the output channel DOx.

Bit i = 1: Overload on the output channel DOx.

11.3.6.2

Block Diagram 4x2 Digitale Outputs 24 V – redundancy capable

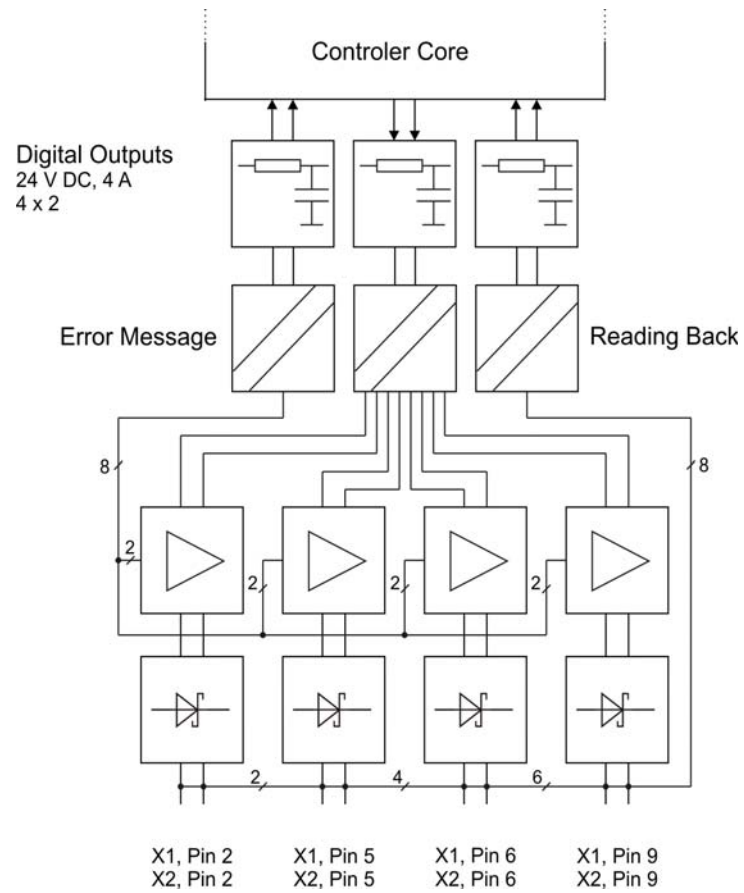

**11.4 6 Digital Outputs DC 110 V
6 Digital Outputs DC 110 V – redundancy capable**

11.4.1 Product Assembly

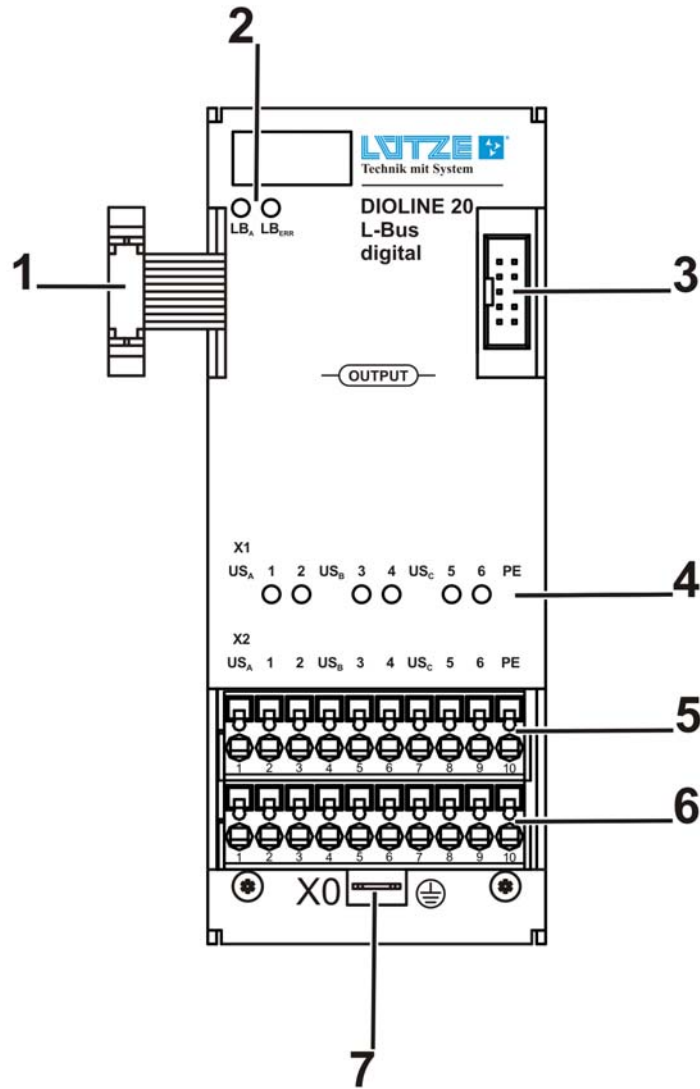

- 1 L-Bus Interface – incoming
- 2 LED Diagnosis Display – L-Bus
- 3 L-Bus Interface – outgoing
- 4 LED Diagnosis Display – Digital Outputs
- 5 Connector Digital Outputs
- 6 Connector Digital Outputs
- 7 Neutral Conductor – Mounting Tab

11.5 LED Display

11.5.1 LEDs – L-Bus



LED	Color	Status
LB_A	green	active
LB_{ERR}	red	Error

11.5.2 LEDs – Output Signals

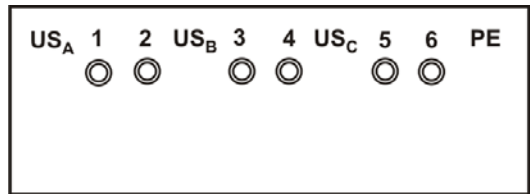

LED	Color	Status
1-6	yellow	Output active

11.5.3

Technical Data

Output 110 V Module

Number	6
Data Width in the Process Image	1 Byte Outputs 2 Byte Inputs Byte 1 = Read-back outputs Byte 2 = Status of the output driver
Current Consumption at DC 24 V	nom. 125 mA
Potential Insulation	Voltage Insulation <ul style="list-style-type: none"> ▪ AC 1.5 kV outputs and electronic ▪ AC 1.5 kV between the outputgroups
Output Voltage	DC 24...110 V
Output Current	max. 2 A per channel
Safety Function	inverse-polarity protection, short-circuit proof, abnormal temperature protection
Channel Type	N-MOS FET
Module Status Flag	Error status of the output driver is entered in the status byte (one bit for each output). The module status flag remains "0". ("0" = no hardware error)
Recommended Error Reaction	Turn off the affected output and check the periphery connections.
External Fuse	B6

**Output 110 V Module
redundancy capable**

Number	6 redundancy capable
Data Width in the Process Image	1 Byte Outputs 2 Byte Inputs Byte 1 = Read-back outputs Byte 2 = Status of the output driver
Current Consumption at DC 24 V	nom. 125 mA
Potential Insulation	Potential Voltage <ul style="list-style-type: none"> ▪ AC 1.5 kV outputs and electronic ▪ AC 1.5 kV between the output groups
Output Current	▪ 0.6 A per channel
Safety Function	inverse-polarity protection, short-circuit proof, abnormal temperature protection
Channel Type	N-MOS FET
Module Status Flag	Error status of the output driver is entered in the status byte (one bit for each output). The module status flag remains "0". ("0" = no hardware error)
Recommended Error Reaction	Turn off the affected output and check the periphery connections.
External Fuse	B6

All outputs have a redundance diode.

11.5.4 Connecting the Digital Outputs

Connect the digital Outputs in 3 groups via the two cage clamps X1 and X2. Follow these steps:

1. Switch off the power.
2. Connect the outputs regarding the pin assignment and the signals.

Digital Outputs 110 V (redundancy capable) Diagnosis

Cage Clamp X1 and X2

Pin	Signal	Description
1	US _A	DC 110 V - Potential A
2	DO 1	Output 1
3	DO 2	Output 2
4	US _B	110 V DC - Potential B
5	DO 3	Output 3
6	DO 4	Output 4
7	US _C	110 V DC - Potential C
8	DO 5	Output 5
9	DO 6	Output 6
10	PE	Protective Earth

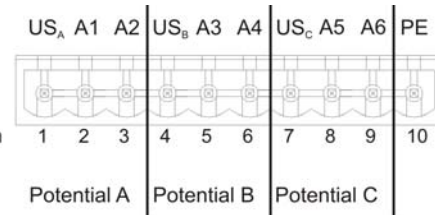

NOTICE

It is not necessary to connect cage clamp X1 and X2. Pin 1 on X1 is bridged with Pin 1 on X2. It is only for simplify thewiring of the vehicle.

Coding

Module	Plug Connectors	Cage Clamp
110 V	Pin 1 and 10	Pin 2, 3, 4 and 7
110 V red.	Pin 1 and 10	Pin 2, 3, 4 and 7

11.5.5

Diagnosis

The error status of the output driver is entered in the status byte. For every output one byte is entered. The module status flags stays "0".

There is no Hardware error if the output is 0. If the output is "1" there is an overload on the output channel.

Byte 1 (Read-back Byte)

Bit 7	Bit 6	Bit 5	Bit 4	Bit 3	Bit 2	Bit 1	Bit 0
0	0	Switching Status (actual) Output Channel DO 6	Switching Status (actual) Output Channel DO 5	Switching Status (actual) Output Channel DO 4	Switching Status (actual) Output Channel DO 3	Switching Status (actual) Output Channel DO 2	Switching Status (actual) Output Channel DO 1

Bit i = 0: Switching status of output channel DO_x is off.

Bit i = 1: Switching status of input channel DO_x is on.

Byte 2 (Status Output Driver)

Bit 7	Bit 6	Bit 5	Bit 4	Bit 3	Bit 2	Bit 1	Bit 0
0	0	Status Output Driver Channel DO 6	Status Output Driver Channel DO 5	Status Output Driver Channel DO 4	Status Output Driver Channel DO 3	Status Output Driver Channel DO 2	Status Output Driver Channel DO 1

Bit i = 0: No error on the output channel driver DO_x.

Bit i = 1: Short circuit or overtemperature at the output channel DO_x.

11.5.6 Operation

11.5.6.1 Block Diagram 6 Digital Outputs 110 V

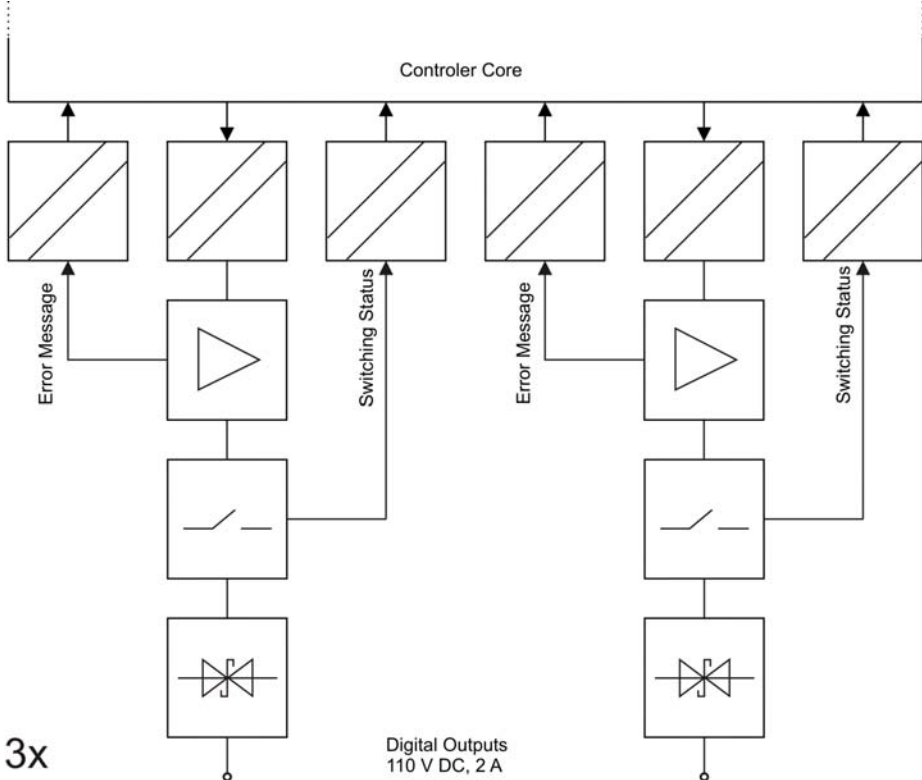

11.5.6.2

Block Diagram 6 Digital Outputs 110 V – redundancy capable

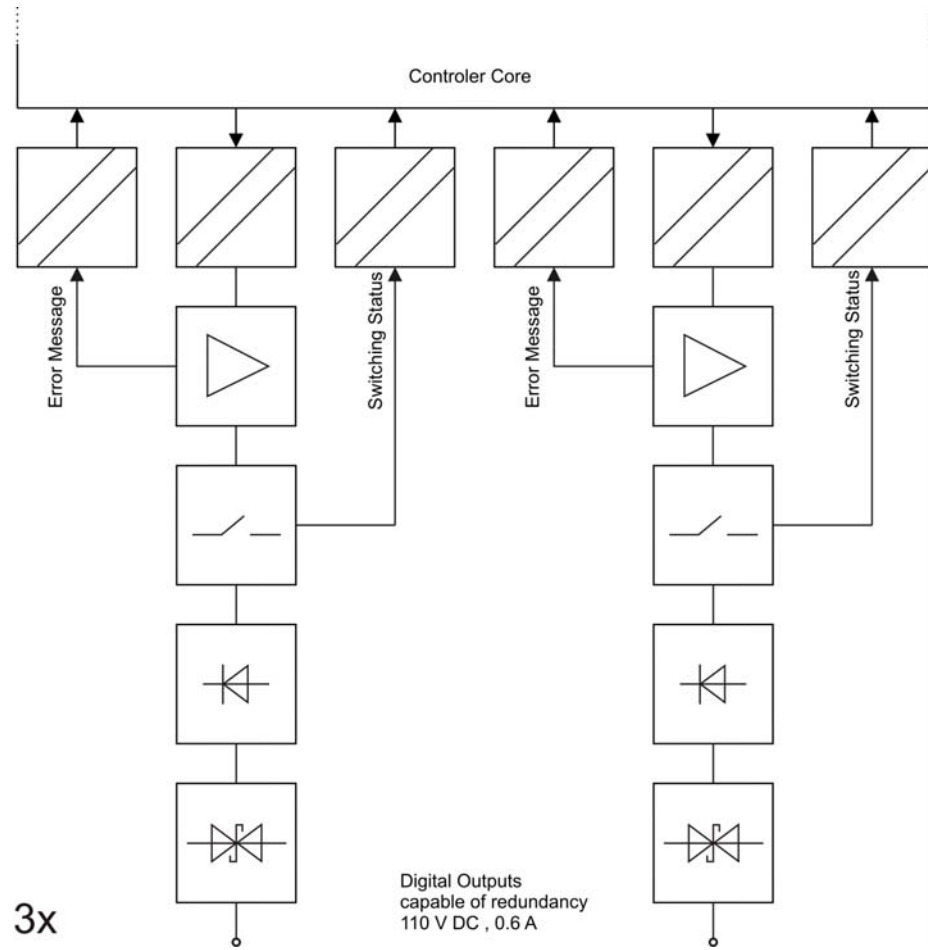

12.1**Characteristics**

- Module with In- and Outputs
Same characteristics as the corresponding in- and output modules
- The four inputs and outputs inside a group have the same potential.

12.2 2x4/2x4 Digital Combi Module DC 24 V

12.2.1 Product Assembly

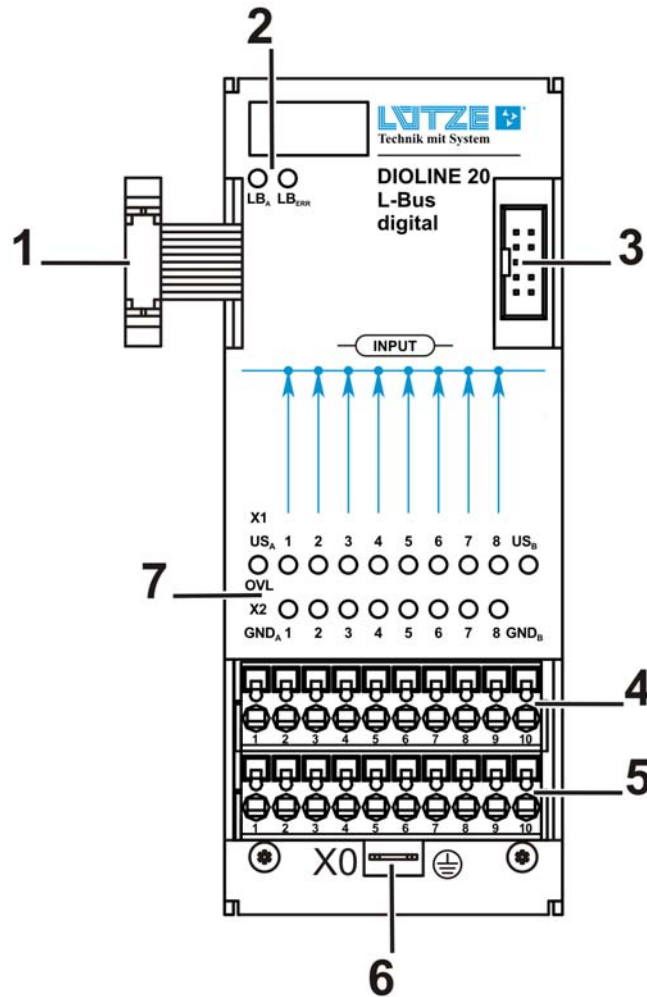

- 1 L-Bus Interface – incoming
- 2 LED-Diagnosis Display – L-Bus
- 3 L-Bus Interface – outgoing
- 4 Connector Digital Inputs
- 5 Connector Digital Inputs
- 6 Neutral Conductor – Mounting Tab
- 7 LED-Diagnosis Display – Digital Inputs

12.2.2 LED Display

12.2.2.1 LEDs – L-Bus



LED	Color	Status
LB_A	green	active
LB_{ERR}	red	Error

12.2.2.2 LEDs – Input Signal

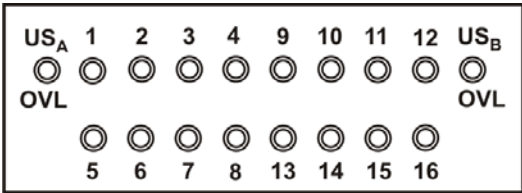

LED	Color	Status
1-16	yellow	Sensor/Actor active
US_A	green	Supply OK
	red	Overload
US_B	green	Supply OK
	red	Overload

12.2.3

Technical Data

Inputs

Number	8
Data width in the processing image	1 Byte Inputs
Current Consumption at DC 24 V	nom. 10 mA
Potential Insulation	Voltage Insulation <ul style="list-style-type: none"> ▪ AC 1.5 kV outputs and electronic ▪ AC 1.5 kV potential A to B
Input Voltage	“0” Signal: <ul style="list-style-type: none"> ▪ DC 0...6 V “1” Signal: <ul style="list-style-type: none"> ▪ DC 12.5...30 V
Input Current	“0” Signal: <ul style="list-style-type: none"> ▪ 0 mA “1” Signal at DC 24 V <ul style="list-style-type: none"> ▪ min 25 mA for 7 ms at powering up, sloping to min. 4 mA “1” Signal Threshold <ul style="list-style-type: none"> ▪ max. 50 mA at DC 30 V inrush current ▪ min. 2 mA at DC 16.8 V constant current

Outputs 24 V Module

Number	8
Data Width in the Process Image	1 Byte Outputs
Current Consumption at 24 V DC	nom. 10 mA
Output Current	2 A; 100 % ED all channels
Threshold (thermic)	10 Hz at 50 % ED
Safety Function	inverse-polarity protection, short-circuit proof, abnormal temperature protection
Channel Type	N-MOS FET
Standby Current	3.0 mA per group
External Fuse	B10

Diagnosis

Module Status Flag	In the error condition of the output driver, the module status flag is set to "1".
Recommended Error Reaction	Turn off the output of the module and check the periphery connections.

12.2.4

Connecting the Digital Outputs and Inputs

Connect the digital outputs and inputs via the two cage clamps X1 and X2. Follow these steps:

1. Switch off the power.
2. Connect the outputs and inputs regarding the pinassignment and the signals.

Digital Combi Module 24 V

Cage Clamp X1

Pin	Signal	Description
1	US _A	24 V DC - Potential A
2	DO 1	Output 1 (1st Byte LSB)
3	DO 2	Output 2
4	DO 3	Output 3
5	DO 4	Output 4
6	DO 5	Output 5
7	DO 6	Output 6
8	DO 7	Output 7
9	DO 8	Output 8 (2nd Byte MSB)
10	US _B	24 V DC - Potential B

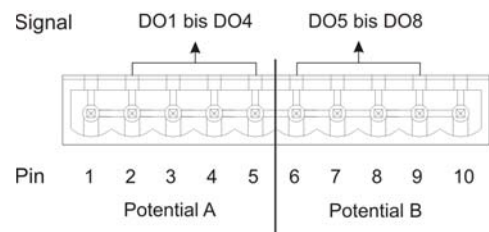

Coding

Module	Plug Connectors	Cage Clamp
24 V	Pin 2	Pin 3 and 4

Cage Clamp X2

Pin	Signal	Description
1	GND _A	0 V - Potential A
2	DI 1	Input 1 (LSB)
3	DI 2	Input 2
4	DI 3	Input 3
5	DI 4	Input 4
6	DI 5	Input 5
7	DI 6	Input 6
8	DI 7	Input 7
9	DI 8	Input 8 (MSB)
10	GND _B	0 V - Potential B

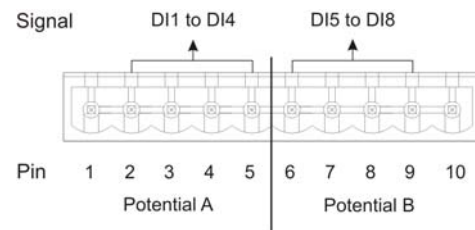

Coding

Module	Plug Connector	Cage Clamp
24 V	Pin 3	Pin 2 and 4

12.2.5 Operation

12.2.5.1 Block Diagram 2x4/2x4 DC 24 V Digital Combi Module

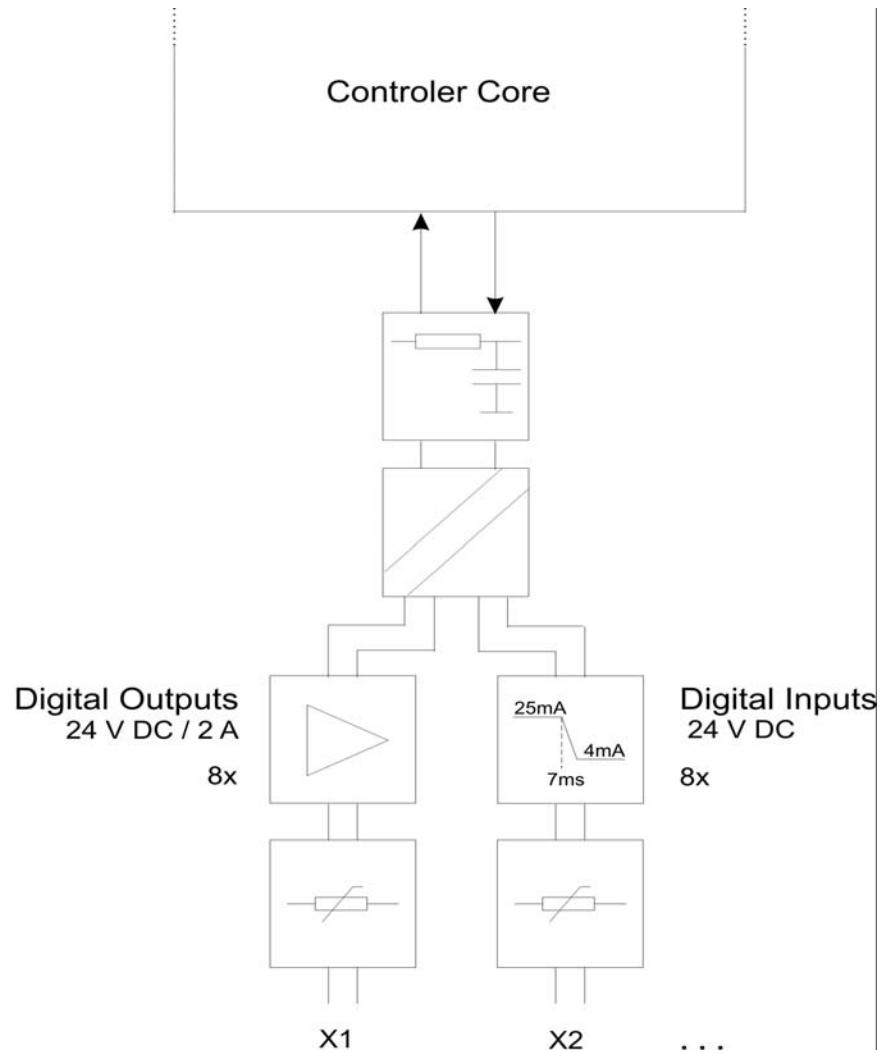

13

Relay Outputs

13.1

Characteristics

- Contacts are hard gold plated and not connected

13.2

Lifetime

Mechanical

The mechanical lifetime of the relay module is 10×10^6 switching cycles.
(relay data)

Electrical

At 0.2 A, 30 V DC, a resistive load and an environmental temperature of 85 °C the electrical lifetime of the relay module is more than 30000 switching cycles.
(relay data)

At 6 A, 150 V DC, a resistive load and an environmental temperature of 85 °C the electrical lifetime of the relay module is more than 5000 switching cycles.
(relay data)

13.3 6 Relay Outputs

13.3.1 Product Assembly

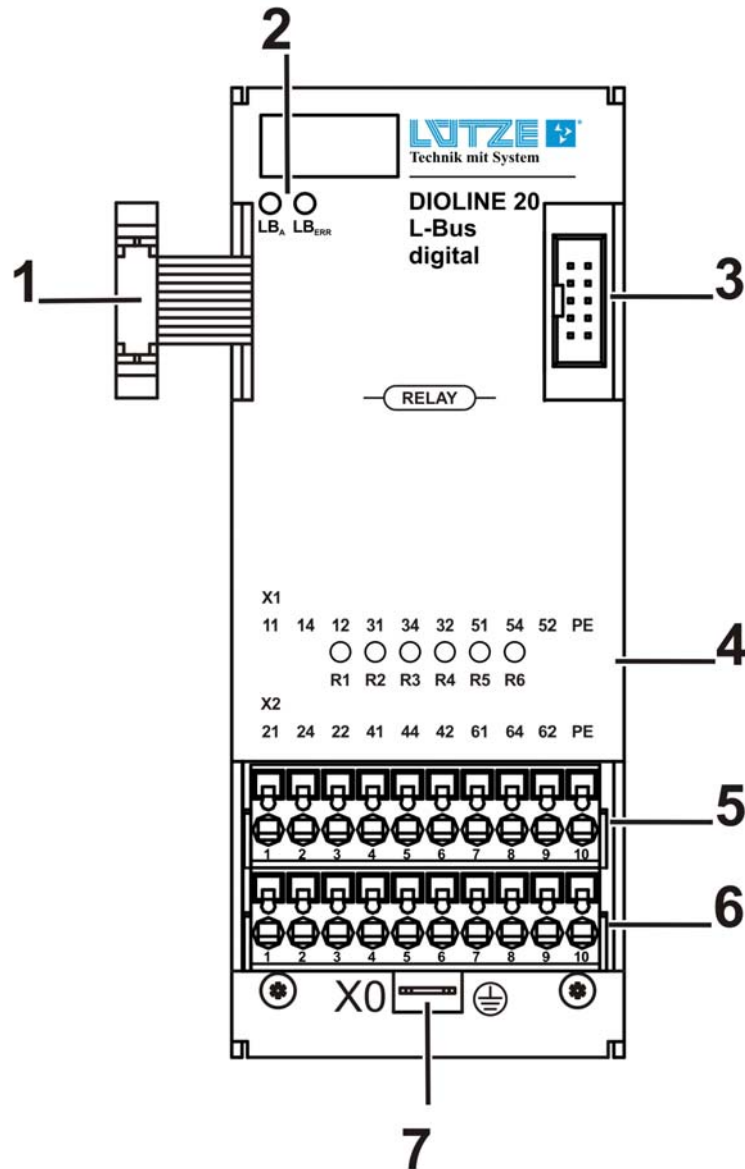

- | | |
|---|---|
| 1 | L-Bus Interface – incoming |
| 2 | LED-Diagnosis Display – L-Bus |
| 3 | L-Bus Interface – outgoing |
| 4 | LED-Diagnosis Display – Digital Outputs |
| 5 | Connector Digital Outputs |
| 6 | Connector Digital Outputs |
| 7 | Neutral Conductor – Mounting Tab |

13.3.2 LED Display

13.3.2.1 LEDs – L-Bus



LED	Color	Status
LB_A	green	active
LB_{ERR}	red	Error

13.3.2.2 LEDs – Output Signal

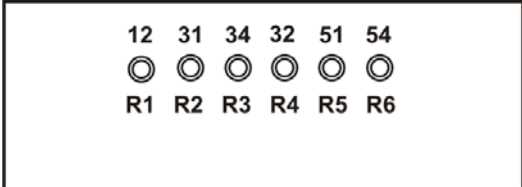

LED	Color	Status
R1-R6	yellow	Aktor active

13.3.3

Technical Data

Output Relay Module

Number	6
Data Width in the Process Image	1 Byte Outputs
Current Consumption at DC 24 V at DC 16,8 V	nom. 90 mA 130 mA
Potential Insulation	Voltage Insulation <ul style="list-style-type: none"> ▪ AC 1.5 kV outputs and electronic ▪ AC 1.5 kV channel against channel
Switch-On Delay (with CAN processing)	13...28 ms
Switch-Off Delay (with CAN processing)	11...15 ms
Output Current	<ul style="list-style-type: none"> ▪ DC 0.4 A at DC 150 V Ohm resistive Load ▪ DC 6 A at DC 30 V Ohm resistive Load ▪ AC 6 A at AC 250 V Ohm resistive Load ▪ 6 A per relay contact, 20 A for all contacts
Safety Function	inverse-polarity protection, short-circuit proof, abnormal temperature protection
Channel Type	Changer
Module Status Flag	The module status flag remains "0". ("0"= no hardware error)
External Fuse	B2 to B6

13.3.4 Connecting the Relay Outputs

Connect the relay outputs via the two cage clamps X1 and X2. Proceed as follows:

1. Switch off the power.
2. Connect the outputs regarding the pin assignment and the signals.

Relay Output

Cage Clamp X1

Pin	Signal	Beschreibung
1	11	Relay 1, C-Contact
2	14	Relay 1, NO-Contact
3	12	Relay 1, NC-Contact
4	31	Relay 3, C-Contact
5	34	Relay 3, NO-Contact
6	32	Relay 3, NC-Contact
7	51	Relay 5, C-Contact
8	54	Relay 5, NO-Contact
9	52	Relay 5, NC-Contact
10	PE	Protective Earth

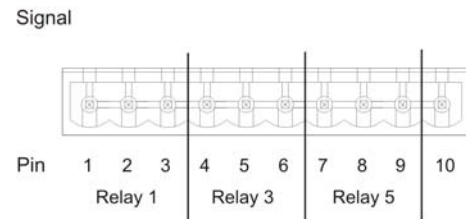

Coding

Plug Connector	Cage Clamp
Pin 4	Pin 2,3,5,6 and 7

Cage Clamp X2

Pin	Signal	Description
1	21	Relay 2, C-Contact
2	24	Relay 2, NO-ontact
3	22	Relay 2, NC-ontact
4	41	Relay 4, C-Contact
5	44	Relay 4, NO-Contact
6	42	Relay 4, NC-Contact
7	61	Relay 6, C-Contact
8	64	Relay 6, NO-Contact
9	62	Relay 6, NC-Contact
10	PE	Protective Earth

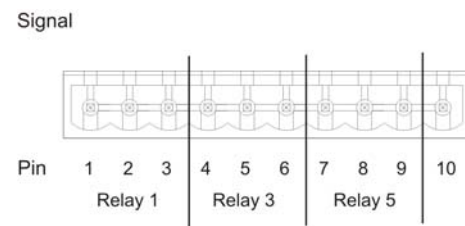

Coding

Plug Connector	Cage Clamp
Pin 5	Pin 2, 3, 4, 6 and 7

13.3.5 Operation

13.3.5.1 Block Diagram Relay Outputs

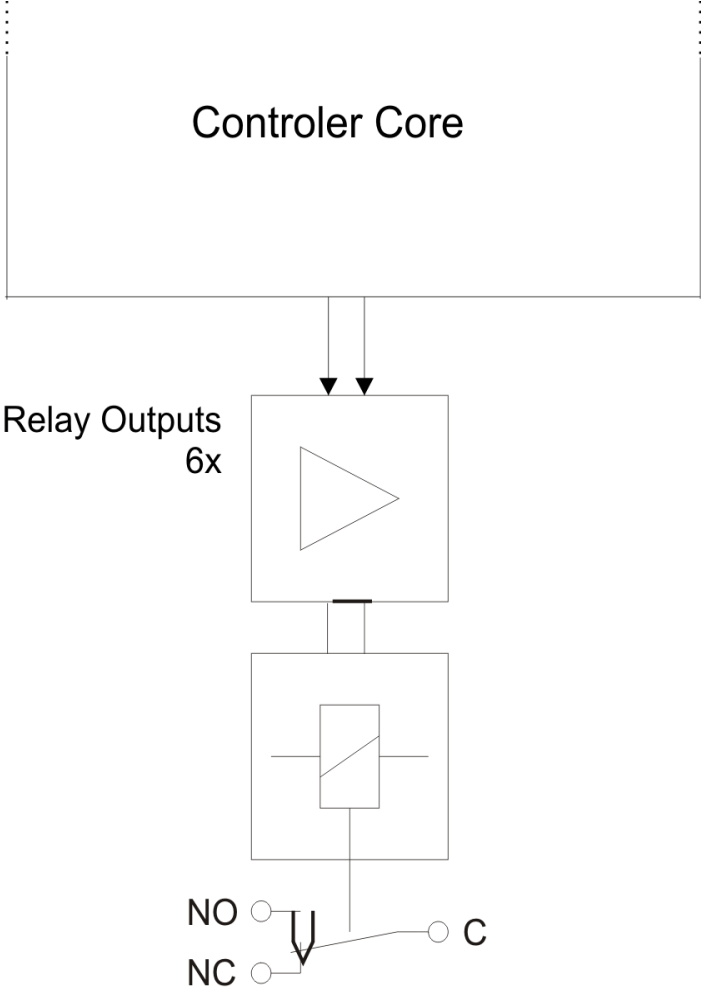

14

Spacer

14.1

Characteristics

- Spacer for project planning
- Does not have any cage clamps

14.2 Product Assembly

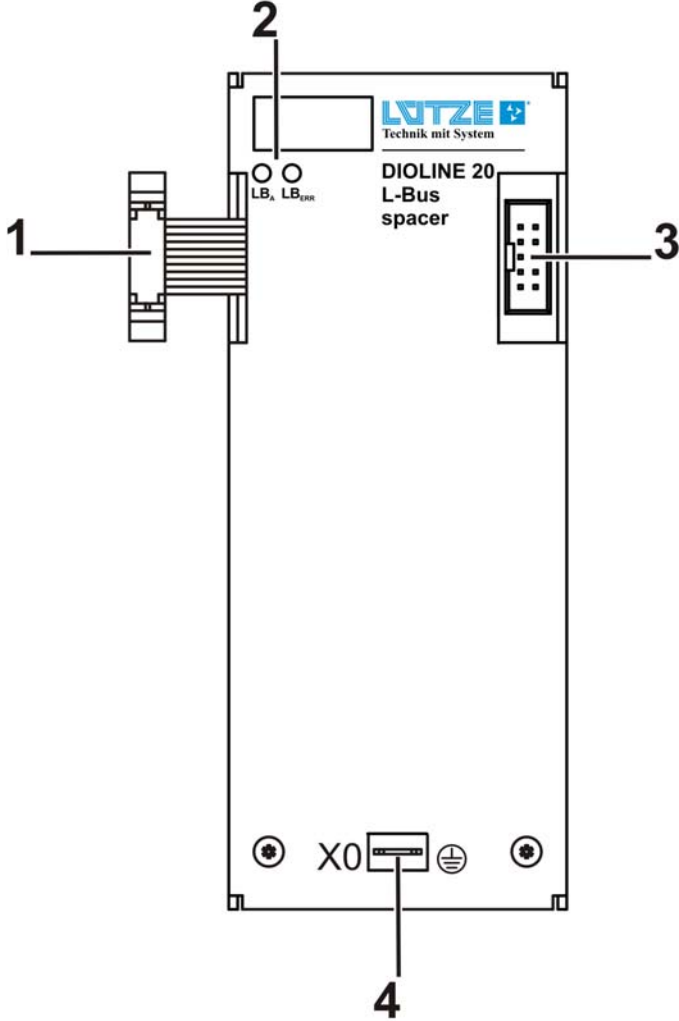

- 1 L-Bus Interface – incoming
- 2 LED-Diagnosis Display – L-Bus
- 3 L-Bus Interface – outgoing
- 4 Neutral Conductor – Mounting Tab

14.2.1 LED Display

14.2.1.1 LEDs – L-Bus



LED	Color	Status
LB _A	green	active
LB _{ERR}	red	Error

14.2.2

Technische Daten

Supply

Ripple	max +/- 10 %
Current Consumption at DC 24 V	nom. 10 mA
Threshold (thermic)	10 Hz at 50 % ED

Spacer

Data Width in the Process Image	1 Byte inputs, content 0x00
Module Status Flag	The module status flag remains "0". ("0" = no hardware error)

15 Demounting

1. Push the module up.
2. Pull the module from the top-hat rail.
3. Push the module down and take the module off the rail.

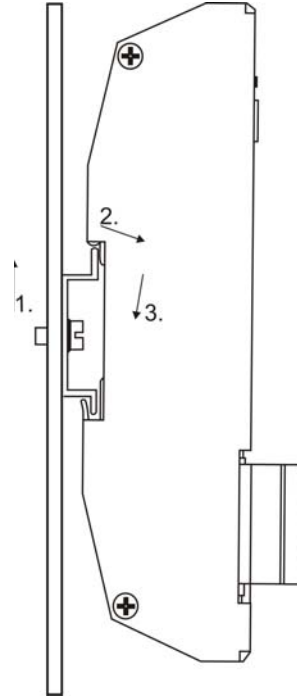

16

Final Shutdown and Disposal

Mind the valid environmental standard of your country for the final shutdown and disposal.

For the final shutdown the device has to be disassembled. Electric Parts must be disposed after the national electronic scrap regulation. You take the responsibility for the shipped article. You have to dispose the article after the terms of use and legal liability on your own costs and exempt the Lütze Transportation GmbH from the responsibilities of §10 passage 2 ElektroG (Take-back obligation of the manufacturer) and any third party in this content.

If you have handled the device to a commercial third party without any contractual acceptance of the disposal, you have to take back the device after the final shutdown on your own cost and the legal liability.

The entitlement of indemnity from the Lütze Transportation GmbH by the customer does not prescribe before two years after the final shut down of the device. The two year deadline of the suspension of statute for limitations can start with a written message about the terms from you to the Lütze Transportation GmbH.

17

Service

If you have any further questions regarding the product or our repairing service please contact us:

Lütze Transportation GmbH
Bruckwiesenstraße 17-19
71384 Weinstadt
Tel.: +49 (0) 7151 6053-545
Fax: +49 (0) 7171 6053-6545
Sales.Transportation@luetze.de

18 Appendix

18.1 Overview – DIOLINE 20 Identifier

Type	I/O-Range	Length (Bytes)		ID (hex)
8 Digital Inputs	8DI	1	0	F2
8 Digital Outputs	8DO	0	1	F1
16 Digital Inputs	16DI	2	0	E0
16 Digital Outputs	16DO	0	2	E1
8 Digital Inputs, 8 Digital Outputs	8DI/8DO	1	1	E2
16 Digital Inputs, 8 Digital Outputs	16DI/8DO	2	1	E3

