

EM-243A DC-MOTOR CONTROLLER 12-42V 50A

FEATURES



- small size
- high current output
- current limit
- zero current limit
- speed setting
- flexible control inputs
- impulse / continuous mode
- rail base mountable
- digital parameter setting
- A-vers. compatible with older version
 - +higher supply voltage area
 - +higher fault output current.
 - +input damping with dip-switch

EM-243A is a full bridge DC-motor starter. It is designed to work with DC-motor in applications where some special functions are needed. Starter has adjustable acceleration and deceleration ramps, which make possible the smooth starts and stops. Adjustable current limit protects motor against overcurrent and it can also be used as an end-stop. This device has also two settable speeds, which are usefull in positioning applications. Control inputs FW and BW start the forward and backward run. STOP is for the motor shut-down but there are also available individual limit inputs for FW and BW directions. SPEED-2 input activates preset speed-2, but it can also be used as input for analog speed control signal 0-5V. FAULT terminal has at the same time input and output function, the pin is normally high, but is pulled down in overheat and conditionally also in current trip situation. If FAULT-line is pulled down externally it will cause a stop and prevent the new start. For example, it is possible to link fault pins of several units together and achieve a synchronous stop. There are 2 selectable control modes, continuous and impulse. In continuous mode the motor runs as long as the control is active. In impulse mode a short comand starts the motor, and only a new impulse will change the status. The card has selectable input logics. Inputs are divided in two groups, control and limit -inputs. Groups can be individually set for NPN or PNP logic. The parameters are set with EM-236 interface unit. Operation of the controller and some of its functional values can also be monitored with EM-236 interface unit.

TECHNICAL DATA

Supply voltage nominal 12-42V, limits 10-55V
 Start up voltage 9V, shutdown voltage 8V
 Idle current typ 15mA
 Motor current max. continuous 50A (at 25°C amb temp),
 40A (at 60° amb temp) and peak 100A (5s)
 Current limit adjustable 1-100A (at start 1.5 times)
 Overheat limit 100°C
 Start and stop ramp adjustable 0-5s
 PWM frequency 2kHz
 Speed input scale (speed-2) 0-5 or 0-10V= 0-100% pwm
 Input control logic: high =4-30V, low=0-1V
 Control input impedances typ. 10kohm
 Control input response time typ 5ms.
 Fault out. NPN open coll. max. 50V / 1A
 Fault in activates $U_{in} < 1V$ (NPN)
 Motor and supply connectors 2.5mm
 Control connectors 1mm
 Dimensions 107x72x40mm
 Dimensions in DIN-rail base 110x80x55mm
 CE-tested for industrial environment (EMC)
 Operating ambient temp (T_a) -40...60°C
 Weight 190g

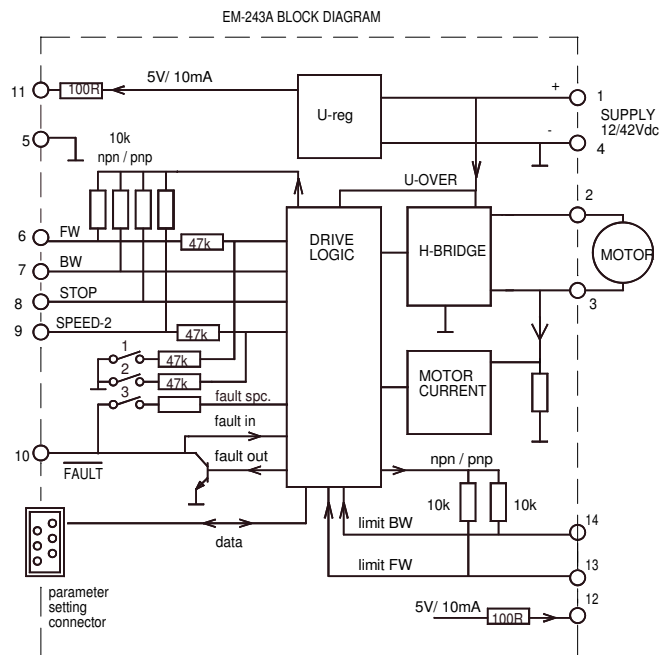

ELECTROMEN Oy

www.electromen.com

CONNECTIONS

Supply voltage recommendation is 12-42VDC and ripple should be less than 30% at full load.
Supply voltage limit is 55Vdc
CAUTION ! Wrong polarity can damage the unit.
CAUTION ! Unit doesn't have an internal fuse, so an external fuse should be added if fuse required.

MONITORABLE VALUES

1/5 Motor current 0-100A (0-100)
2/5 PWM-level-% 0-100% (0-100)
3/5 hour counter (max.65535h)
4/5 start counter (max.65535)
5/5 carry counter for start counter

FAULT-LED signal codes

| | |
|---------------------|------------------------------|
| 1. power on | one blink |
| 2. current on limit | led is lit |
| 3. current trip | fast blinking... |
| 4. zero-cur trip | long blink- short pause... |
| 5. overvoltage | 4 x blink -pause... |
| 6. overheat | short blink- long pause... |
| 7. timeout | 3 x blink + long blink... |
| 8. fault input | 2 x short + 1x long blink... |

ADJUSTMENT AND SETTINGS

Adjusting and parameter setting of eg. current limit value, ramp times and speed-2 value is done with the EM-236 interface unit.
With EM-236 the parameters and adjusted values can also be copied to multiple devices accurately and reliably.

DIP SWITCHES

A-version has a dip swithes, When switch are in OFF position the card will be compatible with earlier version.

Dip-1 ON pos. damping FWD input
Dip-2 ON pos. damping Speed-2 input with 2
Dip-3 ON pos. special Fault output select
Dip-4 ON pos. special clock

SETTABLE PARAMETERS

prog. 243A v1.0 (defaults in brackets)

1 command mode: continuous = 0, impulse= 1 (0)
2 start condition combinations: 0-3 (1)
0= start both direction after I-trip and Stop
1= start only opposite direction after I-trip
2= start only opposite direction after Stop
3= start only opposite direction after I- and Stop
3 input logic combinations 0-3 PNP/NPN (0)
0= command and limit inputs as PNP (positive)
1= command inputs NPN, and limit inputs PNP
2= command inputs PNP, and limit input NPN
3= command and limit inputs NPN (negative)
4 running speed-1: 0-100% / 0-100 (100)
5 running speed-2: 0-100% / 0-100 (50)
Note: If selected to 0 "speed2-input" is used as analog 0-5V speed control input.
6 current limit FW: 1-100A / 1-100 (10)
7 current limit REV: 1-100A / 1-100 (10)
8 Trip combinations: 0-3 (1)
0= no I-trip, no zero-current-trip
1= only I-trip
2= only zero-current-trip
3= both I-trip and zero-current-trip
9 I-trip delay: 0-255ms / 0-255 (20)
10 Fault output combinations: 0-3 (1)
0= I-trip and zero current won't cause fault output signal
1= only I-trip causes fault output signal
2= only zero current causes fault output signal
3= both I-trip and zero current causes fault output signal.
11 overvoltage limit: 15-60V / 15-60 (55)
Overvoltage can be caused by load driving the motor or when braking the speed down but supply can not accept the current back from driver. Exceeding the limit will cause the power stage set to free-wheel state.
With a direct battery supply the brake current is charging the battery and the voltage will not normally rise.
12 load compensation: 0-255 / 0-255 (0)
Load compensation (Rxl) improves low speed and start torque, but too high compensation achieve unstable running. Run motor at low speed (30%) Increase compensation with small steps until motor start behaviour unstable, then decrease value about 10%
13 timeout: 0-255s. / 0-255 (0=not in use) (0)
14 reset for start and hour-counter 0/1 (0)
selecting 1 and push save = reset counters
15 start ramp: 0-5s / 0-500 (100)
16 stop ramp: 0-5s / 0-500 (100)
17 start kick 0-200ms / 0-200 (0)
gives short 0-200ms full drive pulse for start

