



Dopyt

## RÝCHLO-VYPÚŠŤACÍ VENTIL

Séria 6000

6050 M5

Rýchlo-vypúšťací ventil M5

 AIGNEP

- Teplota -20°C do 80°C
- Tlak max. 10 bar
- Telo z poniklovanej mosadze



### POPIS PRODUKTU

## ŠPECIFIKÁCIA

Balenie	10 ks
Materiál balenia	NBR
Materiál tela	Poniklovaná mosadz
Materiál tesnenia	PA6.6
Prevádzková teplota max.	80 °C
Prevádzková teplota min.	-20 °C
Procesné pripojenie	M5
Tlakový rozsah max.	10 bar
Tlakový rozsah min.	0,3 bar
Tvar tela	T
Typ závitů	Metrický

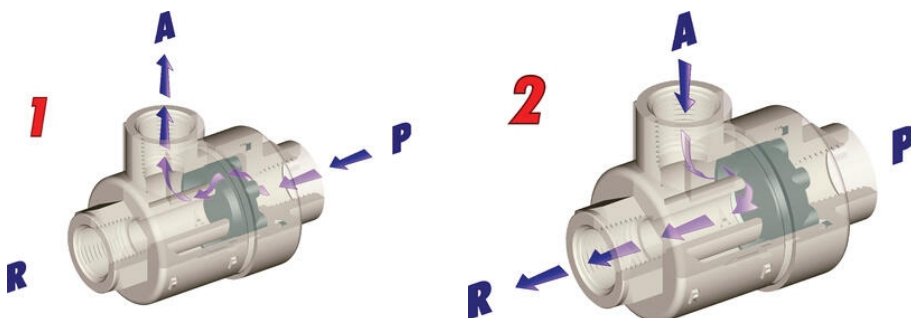

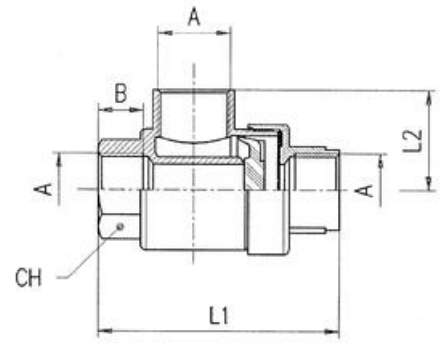

	A	B	L1	L2	CH
6050 M5	M5	5,0	25,0	10,0	10
6050 1/8	1/8	7,5	42,0	19,5	15
6050 1/4	1/4	11,0	54,0	25,0	19
6050 3/8	3/8	11,5	60,5	26,5	22
6050 1/2	1/2	14,0	71,0	32,0	26
6050 3/4	3/4	16,3	87,0	37,0	32
6050 1	1	19,0	109,0	48,0	46