



Dopyt

JÍMKY

Série TW22

TW22-14373241

Jímka navařovací 50x6mm M24x1,5 Ra ≤ 0.76 μm pro senzor 3mm

- Materiál nerez
- Připojení aseptický, navařovací
- 3-A, EHEDG



POPIS PRODUKTU

ŠPECIFIKÁCIA

Dĺžka	135 mm
Insertion length	50 mm
Inside diameter	3 mm
Materiál kontaktnej časti	Nerezová oceľ 316L
Neck length	0,085 m
Plug diameter	6 mm
Zhoda s normami	3-A, EHEDG

Combination examples



Welding ball process connection

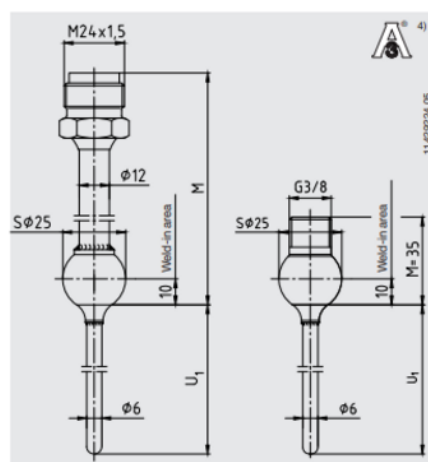

Combination examples



Welding ball process connection

