



JÍMKY

Série SWT52

SWT52G-3907317
Jímka 45mm G1/2B 10x8mm

- Materiál mosaz, nerez
- Připojení G, navařovací



POPIS PRODUKTU

ŠPECIFIKÁCIA

Insertion length	45 mm
Inside diameter	8 mm
Materiál	Zliatina medi
Prevádzková teplota max.	160 °C
Priemer	10 mm
Tlakový rozsah max.	6 bar

Dimensions in mm

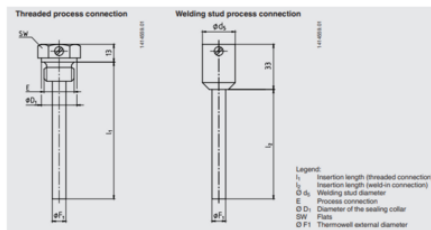

Threaded process connection (Copper alloy, Si35 or stainless steel)

Thermometer	Dimensions in mm				
	l ₁	G	SW	Ø F ₁	Ø D ₅
Model 52	45	G 1/2 B	27	10	26
	63	G 1/2 B	27	10	26
	100	G 1/2 B	27	10	26
	200	G 1/2 B	27	10	26

Welding stud process connection (St35 or stainless steel)

Thermometer	Dimensions in mm		
	l ₂	Ø d ₅	Ø F ₁
Model 52	43	24	10
	80	24	10
	140	24	10
	180	24	10

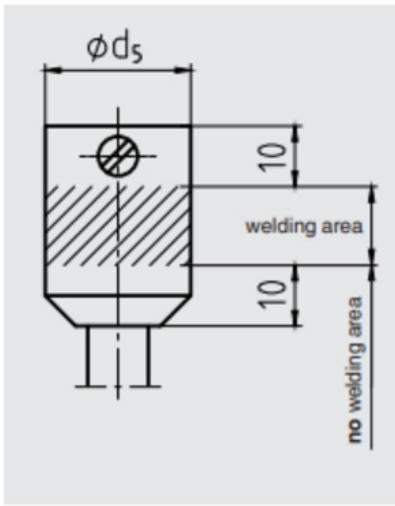

Process connection	Insertion length, l_1 , of the thermometer
Thread	l_1 = insertion length, l_1 , of the thermowell
Welding stud	l_1 = insertion length, l_2 , of the thermowell + 20 mm [0.8 in]

Dimensions in mm

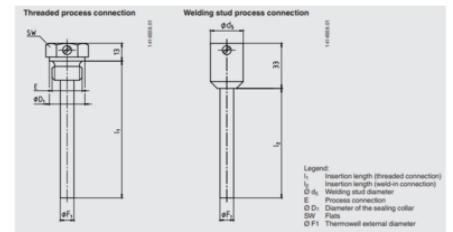

Threaded process connection
(Copper alloy, S335 or stainless steel)

Thermometer	Dimensions in mm				
	l_1	E	SW	$\varnothing F_1$	$\varnothing \varnothing_1$
Model 52	45	G 1/4 B	27	10	26
	63	G 1/4 B	27	10	26
	100	G 1/4 B	27	10	26
	160	G 1/4 B	27	10	26
200	G 1/4 B	27	10	26	

Welding stud process connection
(St35 or stainless steel)

Thermometer	Dimensions in mm		
	l_2	$\varnothing d_s$	$\varnothing F_1$
Model 52	43	24	10
	80	24	10
	140	24	10
	180	24	10

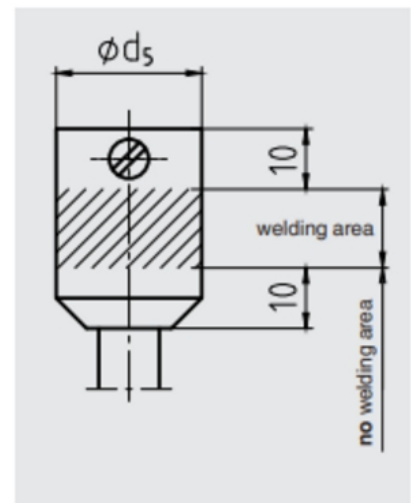

Process connection	Insertion length, l_1 , of the thermometer
Thread	l_1 = insertion length, l_1 , of the thermowell
Welding stud	l_1 = insertion length, l_2 , of the thermowell + 20 mm [0.8 in]